



Ente per le Nuove tecnologie,  
l'Energia e l'Ambiente



*Ministero dello Sviluppo Economico*

## **RICERCA SISTEMA ELETTRICO**

---

# **International Status of Molten Carbonate Fuel Cell (MCFC) Technology**

**S. McPhail, A. Moreno, R. Bove**

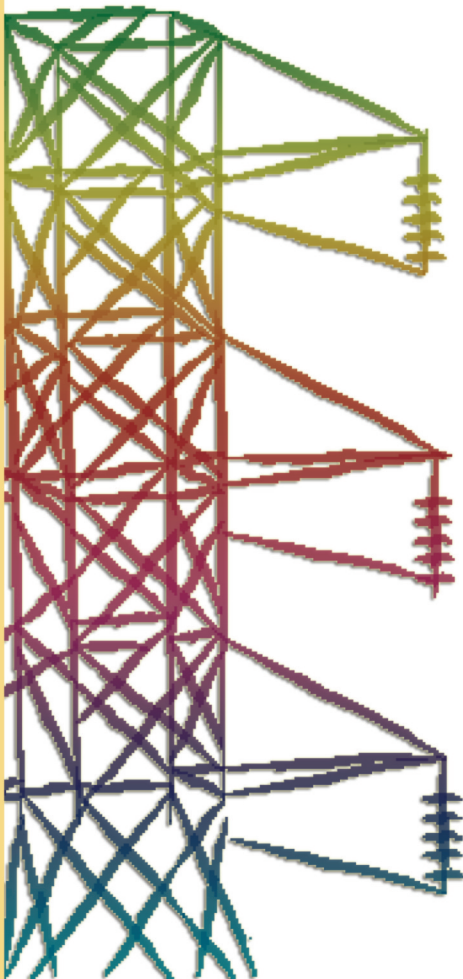



Ente per le Nuove tecnologie,  
l'Energia e l'Ambiente



*Ministero dello Sviluppo Economico*

RICERCA SISTEMA ELETTRICO

## International Status of Molten Carbonate Fuel Cell (MCFC) Technology

*S. McPhail, A. Moreno, R. Bove*

## INTERNATIONAL STATUS OF MOLTEN CARBONATE FUEL CELL (MCFC) TECHNOLOGY

S. McPhail, A. Moreno (ENEA)

R. Bove (JRC – IE, Petten, the Netherlands)

Gennaio 2008

Report Ricerca Sistema Elettrico

Accordo di Programma Ministero dello Sviluppo Economico - ENEA

Area: Produzione e fonti energetiche

Tema: Celle a combustibile per applicazioni stazionarie cogenerative

Responsabile Tema: Angelo Moreno, ENEA

## Indice

<b>1. Introduction</b>	<b>5</b>
<b>2. Molten Carbonate Fuel Cells: state of the art in the world</b>	<b>7</b>
2.1 FuelCell Energy (FCE)	8
2.2 CFC Solutions GmbH	10
2.3 Ansaldo Fuel Cells (AFCo)	13
2.4 Ishikawajima-Harima Heavy Industries	15
2.5 KEPCO (KEPRI) and POSCO Power (RIST)	16
2.6 GenCell Corporation	18
<b>3. Achievements and demonstration systems in the world</b>	<b>19</b>
3.1 Fuel Cell Energy (USA) and CFC Solutions (Germany)	19
3.2 Ansaldo Fuel Cells (Italy)	21
3.3 Ishikawajima-Harima Heavy Industries (Japan)	23
3.4 KEPCO (KEPRI) and Posco Power (Korea)	25
3.5 GenCell Corporation (USA)	25
<b>4. Potential customers and market</b>	<b>26</b>
<b>5. Concluding remarks</b>	<b>29</b>
<b>Annex – MCFC technology explained</b>	<b>30</b>
A1. General features	31
A2. Materials state of the art	32
A3. Stack and balance of plant design	33
<b>References</b>	<b>38</b>

## **Acknowledgements**

The authors would like to thank all the contributors to this report. In particular, information was provided by Mauro Scagliotti from CESI Ricerche, Biagio Passalacqua and Arturo Torazza from Ansaldo Fuel Cells (Italy), Manfred Bischoff and Gerhard Huppmann from CFC Solutions GmbH (Germany), Mohammad Farooque from FuelCell Energy (USA), Dan Connors from GenCell Corporation (USA), Kazumi Tanimoto from National Institute of Advanced Industrial Science and Technology (Japan), Yoshihiro Mugikura from CRIEPI (Japan), Tae-Hoon Lim and Sung Pil Yoon from KIST (South Korea). The north-American MCFC developers acknowledge the support of the Department Of Energy over the years.

## 1. Introduction

Molten Carbonate Fuel Cells (MCFC) are currently being demonstrated in several sites around the world. The typical power size is of several hundreds kW, however, a 40-125 kW MCFC system for mid size commercial, industrial and municipal applications was developed by GenCell Corporation, and multi-MW systems are going to be demonstrated in Europe [1], USA [2] and Japan [3].

Although there are demonstration programs all around the world, a strong R&D activity is also being undertaken by R&D organizations, industrial companies, and universities. In fact, there are still technical issues to solve before MCFC can penetrate the market and compete with traditional energy systems. In particular, increasing useful service life and reducing costs represent two important priorities upon which R&D is focused.

Durability is limited by corrosion within the cell components, electrolyte loss and due to dissolution of the cathode into the cell matrix, eventually resulting in nickel shorting of the two electrodes. While increasing the stack durability also implies decreasing the system operating and maintenance (O&M) costs, including that of stack replacement, other cost reduction activities are needed. These include increasing power density (to reduce investment cost maintaining equal power yield), and exploring less expensive manufacturing processes. In addition, mass production will contribute substantially to cost reduction.

In the present paper, a review is offered of the current status of MCFC systems development and application in the world through the extensive demonstration activities of the main players in the field. But before that, two important questions should be addressed, namely:

### *Why Molten Carbonate Fuel Cells?*

The MCFC offers high electric energy conversion efficiency (about 50% based on Lower Heating Value) in a simple cycle configuration, so that it can significantly reduce the exploitation of non-renewable as well as renewable energy sources.

In addition, for equal power production, a high efficiency is translated into reduced carbon dioxide emissions.

The MCFC operates at about 650 °C, thus, differently from low temperature fuel cells, no precious metal is required as the fuel catalyst. Together with production cost saving, the main consequence of this is that carbon monoxide is not a poisoning element, but, on the contrary, that it can be used as a fuel. This peculiarity allows the utilization of a variety of CO-containing fuels, such as hydrocarbons, syngas derived from biomass or coal, landfill gas, gas derived by industrial or agricultural by-products.

### *Does the MCFC require a hydrogen economy?*

As mentioned above, the MCFC can operate on a variety of fuels, thus supporting a better security of supply. Hydrogen is one of the fuels that the MCFC can employ, but it is not the sole fuel. Actually, MCFCs have primarily been developed to be operated on natural gas. At present, for economical and ecological reasons, there is a strong interest towards the use of secondary fuels, of which biogas produced from anaerobic digestion of renewable resources is an important example. Due to the lack of a hydrogen infrastructure, no company is currently planning any demonstration of MCFC power plants on hydrogen. In the eventual case of a hydrogen economy, however, the MCFC can efficiently convert hydrogen into electricity, like all fuel cell types.

## 2. Molten Carbonate Fuel Cells: state of the art in the world

Fuel cell systems based on MCFC technology are under development in Italy, Japan, Korea, USA and Germany. Since the 1990s, MCFC systems have been tested in field trials in the range between 40 kW<sub>el</sub> and 1.8 MW<sub>el</sub>.

Figures 1a [4] and 1b [5] show the relevant quantity of installed MCFC power, compared to other fuel cell technologies, for systems with a nominal power higher than 10 kW. The high number of MCFC installations is mainly due to the strong role played by the American company, FuelCell Energy (FCE) and the German CFC Solutions (formerly MTU CFC Solutions) in putting their products in operation. CFC Solutions developed its 250 kW system, called *Hot Module*, based on FCE's fuel cell stacks.

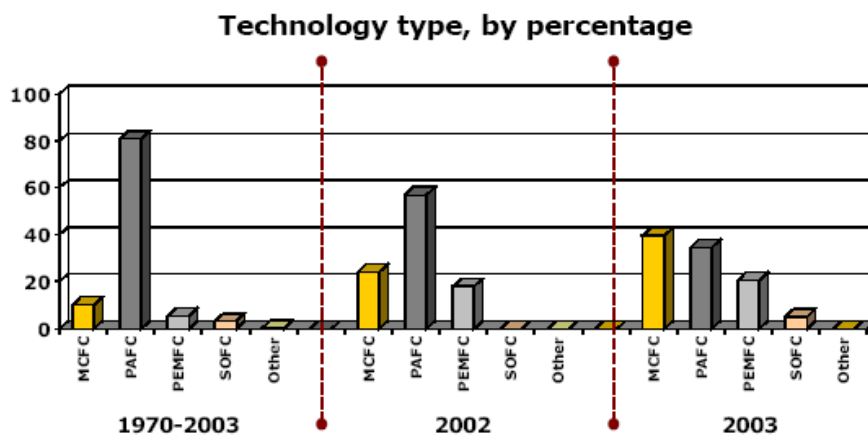

Figure 1a. Installed power by technology type 1970 - 2003 (By permission of Fuel Cell Today)

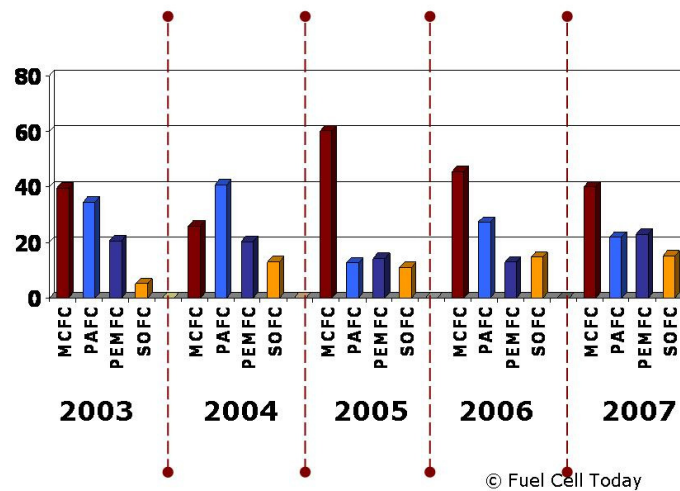

Figure 1b. Percentage of installed power by technology type from 2003 to 2007



Figures 1a and 1b also show that, during the period 1970-2003, Phosphoric Acid Fuel Cells (PAFC) covered a dominant role for this power range, while in the last two years many more MCFC units have been installed.

Six developers of MCFC technology are considered as the major in the world:

1. FuelCell Energy (FCE, USA)
2. CFC Solutions (Germany)
3. Ansaldo Fuel Cells (AFCo, Italy)
4. Ishikawajima-Harima Heavy Industries (IHI, Japan)
5. POSCO/KEPCO consortium and Doosan Heavy Industries (Korea)
6. GenCell Corporation (USA).

A brief description of them follows.

**2.1 FuelCell Energy (FCE)** is a world leader in the development and manufacture of high efficiency fuel cells for clean electric power generation with products ranging from 300 kW to 2.4 MW and has been a fuel cell technology developer for over 30 years. FCE has the biggest high temperature fuel cell manufacturing plant currently operational, in Torrington, CT, with a capacity of 50 MW/year. Its headquarters are located in Danbury, CT (USA).



Figure 2. King County Power Plant (courtesy of FCE)

As of 2007, close on 40 FCE power plants have been installed in USA for a total of 11.5 MW, 15 in Asia (mainly through the sales right agreement with partners Marubeni Corporation, Japan, in place since 2001 and renewed in May 2006) amounting to 8.5 MW, and 12 in Europe (the latter being CFC

plants with FCE technology, see also paragraph 2.2), corresponding to about 4.5 MW. Figure 2 depicts a picture of the 1 MW King County Power Plant (Renton, WA), operated on biogas from a waste water digester.

## Product characteristics

FCE has developed three products:

- DFC<sup>®</sup> 300MA (300 kW)
- DFC<sup>®</sup> 1500 (1.2 MW)
- DFC<sup>®</sup> 3000 (2.4 MW)

Their common characteristics are:

- High temperature, high efficiency, carbonate fuel cell power plants for base load commercial and industrial applications
- Certifications for product safety, interconnection, performance and installation
- High value waste heat by-product for cogeneration
- Internally generated hydrogen from readily available fuels such as natural gas
- Quiet operation: no moving parts incorporated in the generating mechanism
- Very low emissions (NO<sub>x</sub>< 0.3 ppmv, SO<sub>x</sub>< 0.01 ppmv, CO< 10 ppmv, VOC< 10 ppmv)

FCE installations are operating at customer sites today. In addition to the above developed products, FCE is targeting two future systems:

- Shipboard fuel cell system that would run on diesel fuel and provide “hotel” (non-propulsion) power to a new class of Navy ships.
- DFC-ERG (Direct Fuel Cell-Energy Recovery Generation), a hybrid concept combining the Direct Fuel Cell (DFC<sup>®</sup>) and an unfired gas turbine. The fuel cell is coupled with an upstream expansion turbine which reduces high-pressure gas streams for gas transport to end-users (“let-down stations”, as in long-distance gas pipelines) and generates electricity. Some of the expanded gas is then converted in an MCFC to create further electricity and reheat the gas cooled by the expansion process. In this way, a combined electrical efficiency of 60% can be achieved.

**2.2 CFC Solutions GmbH** in Ottobrunn near Munich (Germany), a Tognum Group company, develops and now markets an environmentally-friendly solution for decentralized and efficient power supply applications, based on carbonate fuel cells. CFC Solutions has considered the low carbon dioxide or carbon-neutral production of electrical and thermal energy always as a main target; therefore the use of biogenic fuels or residual gases as primary energy sources has played an important role at the development stage already.

HotModule type fuel cell plants currently provide an output of approx. 250 kW electrical and 170 kW thermal. The electrical efficiency in AC applications is almost 50%. Within the cells, the electro-chemical process runs at around 600 to 650 °C. This high operating temperature allows:

- the transformation of hydrocarbons into hydrogen (internal reforming) to take place within the cells
- the use of nickel as an inexpensive catalyst material
- the extraction of useful heat at elevated temperatures.

Typically the heat can be utilized as high-temperature heat at 400 °C and as low-temperature heat at 60 °C.

The HotModule owes its name to the design of the plant: all “hot” parts – including the fuel cell stack – are housed in one vessel. A key feature of the HotModule is its operation with the fuel cell stack in a horizontal position. This enables feeding the fuel gas from below while the weight of the stack automatically seals off the stack on the fuel gas side. The HotModule is suitable for operations with natural gas, biogas, sewage gas and syngas, as well as methanol.

### *Prototypes, projects and experiences*

The first HotModule installations were put into operation by 1999, running on natural gas as fuel. In the meantime the HotModules have proven their suitability also for methanol, sewage gas and biogas in continuous operation. They are also suitable for dual-fuel systems, which allow a quick change from one fuel to another, like natural gas to methanol or visa versa, so that one energy source can be held in reserve.

Up to now (beginning of 2008) CFC Solutions has installed more than 20 HotModules in Europe. Application fields are industry, hospitals, sewage works, biogas plants, district heating systems and computer centres or telecommunications installations. These



Figure 3. The “HotModule” system (courtesy of CFC)

plants have successfully completed a total of 300,000 operating hours (i.e. a cumulative total of 35 operating years). The durability of the HotModule has been demonstrated in a clinic application, where 30,000 operating hours using one single fuel cell stack have been achieved.

### Latest product developments

CFC Solutions is currently expanding the product range: through modifications to the original HotModule design, power plant systems with higher capacities become available, based on standardised components. The HM300 product line can be manufactured in a range from around 250 kW to 500 kW by equipping the modules with stacks containing a variable number of fuel cells. In the medium term (see product line overview at end of text), HotModule systems in the Megawatt range will become available.

The synergies within the Tognum Group also allow the implementation of hybrid systems by combining the HotModule with the stationary internal combustion engine-driven CHP plants supplied by the sister company MDE Dezentrale Energiesysteme GmbH, Augsburg (Germany). MDE’s 400 product line with an electrical output of up to 400kW is optimised for operation with biogas, sewage gas, landfill gas and natural gas. With these hybrid systems, the HotModule operates continuously to cover the base load demand, while the engine-driven CHP provides the power for the peak loads.

Based on this product spectrum, CFC Solutions' programme now includes environmentally friendly solutions for stationary, low noise power production in cogeneration (heat and power) and tri-generation (heat, power and cooling) applications. The high electrical efficiency of almost 50% on part-load and full-load operation, the fuel utilisation efficiency of up to 90% and the neglectable emissions are of vital importance in all areas of application. Usable heat at a temperature of around 400 °C is a major advantage for the production of process steam, or for providing cooling in absorption chillers.

### *Special fields of application for the HotModule*

In hospitals or district heating plants, the HotModule has a major advantage over conventional CHP plants. The fuel cell does not need moving parts, what makes its operation quiet and vibration-free; expensive enclosures or noise-reduction measures are not necessary.

The HotModule's fuel flexibility and its independence of the power grid (keyword island operation) are advantageous for a number of highly-sensitive industrial processes and computer centres. Electricity generated by the HotModule is of high quality, free of interruptions and grid feedback. In addition, it continuously provides the required thermal energy needed for the cooling of computer installations.

Fuel cell-engine hybrid systems offer advantages where there is a varying energy demand and/or where optimal use of a fluctuating gas production is the main priority, like in sewage plants or for biowaste utilisation, for instance. Here, electricity and heat production can be directly adapted to the actual gas production as needed.

Another product variant is the HotModule for marine applications, which ensures an environmentally-friendly power supply on natural-gas powered ships. The first installation of a HotModule for this application will take place on a supply ship during 2008.

### HotModule Product Lines

<u>HotModule HM300 product line</u>	<u>Power class</u>
• HM310	300 kW
• HM320	400 kW
• HM330	500 kW
<u>HotModule hybrid</u>	
• HM320 + MDE400 gas engine	700 kW
<u>HotModule marine version</u>	
• M-HM320	400 kW
<u>HotModule Megawatt product line</u>	
• HM360	1 MW
• HM380	2 MW

**2.3 Ansaldo Fuel Cells (AFCo)**, situated in Genova, Italy, was formed in 2001 to continue the work carried on by Ansaldo Ricerche for over 20 years. In 2004 the private Company EnerTAD, presently owned by ERG, and Fincantieri have joined AFCo as minority shareholders, thus giving a new impulse, particularly to the perspectives of renewable energy exploitation and naval applications.

The AFCo mission is the development, industrial production and commercialization of fuel cells and particularly Molten Carbonate Fuel Cell power plants in the middle size range, from 0.1 up to a few MW.

To this effect, AFCo has finalized an experience coming from over 20 years of investment and development activity in the fuel cell field. The main fallout of such experience has been a thorough demonstration programme which has seen 6 units being built and tested in different operating environments and with different fuels. The stacks used for the demonstration phase, FA150, were coupled to form bigger units in a proprietary configuration (named TWINSTACK®) that integrates the stacks and a Modular Integrated Reformer (MIR, more details in Annex 1).

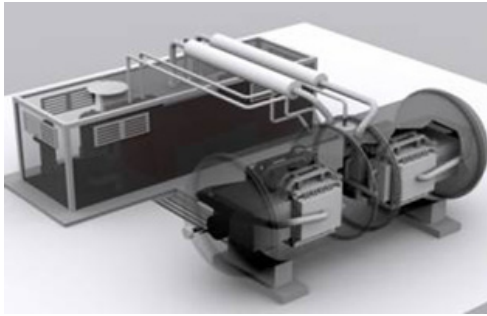

Figure 4. AFCo Series 2TW demonstration Power Plant (courtesy of AFCo)

Presently, the feedback from the demonstration programme is being implemented into two new classes of fuel cell stacks, the FA200 series (1<sup>st</sup> stack assembled at the end of 2007) which will mainly be used for stationary units up to 0.5 MW, and the FA400 series, to be released, targeting MW class and over for stationary applications. Also compact units are being developed for special projects.

This advancement fits into AFCo “Product Development & Industrialization” programme, a substantial effort (both financial and technical) to obtain a commercial product that can be sold with profit, warranties and liabilities on the unsubsidized market.

AFCo engineering activities and technological laboratories are located at the headquarters in Genova (Italy). This is where stack design, R&D activity, system engineering and small-scale plant testing takes place. Not far from there, near Alessandria, is where the *Tecnodemo* pilot plant is being operated, for well over two years now, clocking in excess of 20,000 hours. A “Research Campus” is being established there as well, in collaboration with ENEA and Italian Universities. In 2004, a new factory for porous components manufacturing and stack assembly was inaugurated in Terni (Italy), with an operational capacity of 2.5 MW/year, upgradeable to 10 MW/year.

Figure 4 depicts the configuration of the AFCo Series 2TW plant, while the evolution of the stack component design in the last 10 years is shown in figure 5.

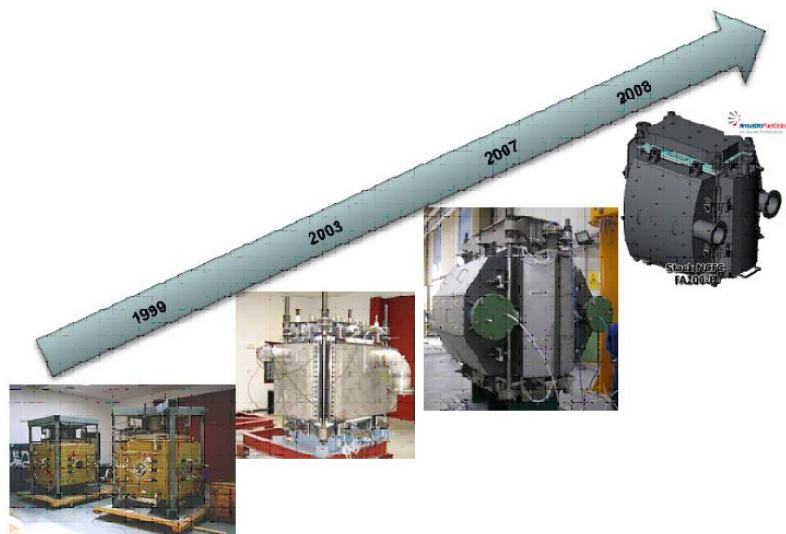

Figure 5. AFCo stack design evolution (courtesy of AFCo)

### Product characteristics

The “Series 2TW”, used in the demonstration phase, is a hybrid plant, incorporating four MCFC stacks and a micro-turbine. It has the following main characteristics:

<i>Rated power</i>	up to 500 kW
<i>Operating pressure</i>	3.5 abs. bar
<i>Configuration</i>	TWINSTACK <sup>®</sup>
<i>Reforming</i>	MIR-Modular Integrated Reformer (for natural gas)
<i>Fuel</i>	Landfill-gas, bio-fuels, diesel-oil, hydrogen, CO, coal-gas etc.

The 2-Twinstacks configuration used for the Series 200 will in principle be maintained for both mid-size (0.5 MW class) and for MW class plants, where new stacks with much higher rated power will be used.

A compact version of the plant is also foreseen for special applications such as military or remote areas.

As part of the Product Development plan a few more plants are foreseen to validate further steps toward the commercial product. AFCo has recently signed an important cooperation agreement with ENEL, the major Italian Electric Utility, that, among other R&D topics, foresees the installation in 2009 of a 0.5 MW plant based on the new FA200 stacks in ENEL experimental facilities in Livorno, Italy. The plant is expected by both parties to be followed by a 1 MW plant based on FA400 stacks in 2011.

## **2.4 Ishikawajima-Harima Heavy Industries**

**(IHI)** (Japan) under the coordination and the support of **NEDO** (New Energy and Industrial Development Organisation), has the responsibility for commercializing MCFC technology that is in development since the early 1980s.

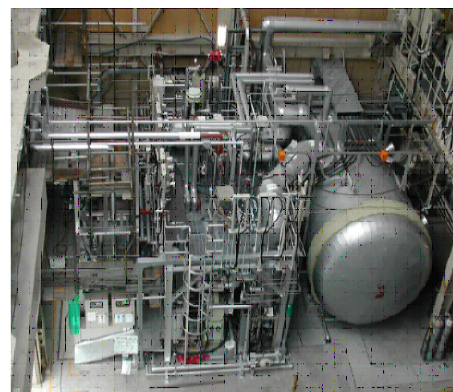

Figure 6. Full view of 300 kW class Compact System in Kawagoe Test Station



Their mission, started in 2000, is to develop systems ready for commercialization, i.e. with high reliability, compactness and low costs. In 2002-2003 the demonstration phase started and four 300 kW MCFC systems have been installed. Two of them at Chubu Electric power stations to demonstrate a lifetime of more than 10,000 hours. The third is a hybrid system (50 kW micro-gas turbine from Toyota Turbine & Systems) installed at a Toyota Motors car plant facility. A fourth system has been recently installed at the Aichi International Exposition and operated on digester gas produced from waste collected within the exhibition area. The 300 kW module (figure 6) operates at a pressure of 4 bar, and a current density of 200 mA/cm<sup>2</sup>.

**2.5 KEPCO (KEPRI) and POSCO Power (RIST)** are currently the two main contractors for a project realizing a 250 kW MCFC power plant within 2009. KEPRI (Korean Electric Power Research Institute), formerly the Electricity Laboratory of KEPCO (Korean Electric Power Company, the world's fifth-largest electric utility), was established in 1961, and with more than 40 years of experience, it has been leading the Korean national electrical technology development.

POSCO, with about 30,000 employees, is one of the top steel companies in the world, and has a strategic license, manufacturing and distribution agreement with USA's FCE to market the latter's DFC units and manufacture the BOP, capitalizing on POSCO's strong manufacturing capabilities and economies of scale to improve the Balance-of-Plant costs. The Research Institute of Industrial Science & Technology (RIST) is the research center that POSCO established and invested in for developing material and energy related technology. HyoSung Heavy Industry (HHI) which is top electric device manufacturing company and SamSung Engineering (SECLE) also participated this program for developing PCS and system detail design. Sub-contractors of the 250 kW R&D&D program are the Korea Institute of Science & Technology (KIST), National and private Universities. The main goal of the present R&D activity is to demonstrate a commercial prototype. In particular, this means:

- to improve the technology in order to obtain 20 000 hours lifetime (10 000 hours on full scale stack)
- to optimize and reduce the size of the Balance of Plant (BoP).

Before the construction of 250 kW commercial prototype module units, a 100 kW-class demonstration plant is being developed as an interim target to verify the domestically developed MCFC technology. The 100 kW-class demonstration plant was constructed at the site of Boreyong power plant in Chungnam and was put into operation by the end of 2005. Recently (2007), a 75kW stack with 7500 cm<sup>2</sup> electrode area was installed at



Figure 7. 75 kW test stack for the development of the 250 kW system at KEPCO

the Boryeong test stand and operated for evaluation – see figure 7.

Very recently, a factory was built in Pohang with a 50 MW/year capacity; it is scheduled to begin production in August 2008.

Another important Korean developer in the area of MCFC systems is **Doosan Heavy Industries & Construction (DHI)**, a world class steam

power plant and desalination plant manufacturing company. They have initiated the development of 300 kW MCFC models for power generation to be commercialized in 2012. Recently, a 3-year government project to develop a stationary 300 kW Molten Carbonate Fuel Cell power plant has been launched. DHI, as main contractor of this project, collaborates with KIER and Korea Midland Power. The total budget for this project is US\$ 55.6 million. DHI plans to build research and production facilities necessary for cell component fabrication and stack manufacturing on the company's laboratory area in Daejeon by early 2008. The first 300 kW prototype will be released by



Figure 8. A 25 kW-class Internal Reforming MCFC stack at DHI

late 2010, and the commercial model will be developed by 2012. By virtue of the established technologies of DHI & Doosan Babcock in power plant system engineering, various types of the applied products, including a large scale hybrid system for combined cycle power plants and fuel cell-combined plants with other industrial systems will be developed by 2015.

DHI is developing all technologies related to MCFC products, such as component design and fabrication, stack design and manufacturing, and system engineering for BOP. In 2006, DHI verified its own technology by operating a 25 kW stack – the first of its kind in Korea. DHI's stack adopts a unique internal reforming system design. Various types of BOP are being studied to enhance the operability and to maximize the system's efficiency.

**2.6 GenCell Corporation**, located in Southbury, CT (USA), is a fuel cell developer and manufacturer with a mission to reduce fuel cell capital costs to first make them economically viable for the market's early adaptors, and then to further reduce costs to



Figure 9. 40 kW operational prototype (courtesy of GenCell)

penetrate the mass market. GenCell started development work in 1997 and has fourteen patents (issued or pending) to protect its proprietary fuel cell designs and manufacturing processes.

GenCell's MCFC system is positioned in the 40-125 kW distributed generation market, where there is the largest number of potential end-users. Commercial scale prototype stacks are being constructed and operated successfully. The integral chamber in the MCFC is used as a catalytic indirect internal reformer (patent pending). Figure 9 is a picture of the 40 kW stack prototype.

### 3. Achievements and demonstration systems in the world

#### 3.1 Fuel Cell Energy (USA) and CFC Solutions (Germany)

A significant worldwide operational experience has been accumulated with 250 kW power plants on different fuels and applications.

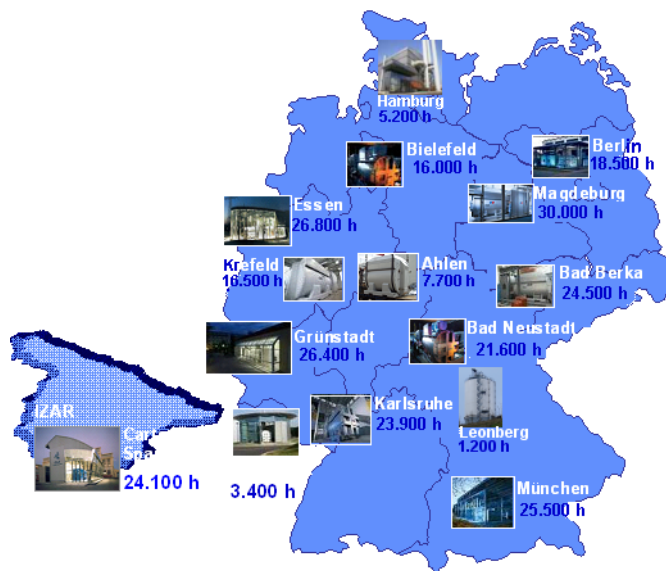

Figure 10. CFC HotModule Installations in Europe (2007, courtesy of CFC Solutions)

Based on this experience, Direct Carbonate Fuel Cells can be considered ready for distributed power generation applications.

However, efforts for further cost reduction are strongly needed and are a continuing part of the companies' strategy. FCE is also looking at other possible applications (hybrid systems) and markets such as marine application.

Specifically, the achievements of the two developers sharing the same stack technology, can be summarized as follows:

- Over 60 systems fielded at customer sites in the US, Japan, and Europe (fig. 10)
- Over 200 million kWh of electricity generated to date at customer sites
- Expanded manufacturing, testing facilities
- Identified and implemented cost reductions, achieved certifications, completed product standardization
- Completed sub-megawatt field trial program, field follow program in progress, field units reaching 45-47% efficiency
- Initiated field trial of DFC1500, DFC3000
- DFC-ERG field trial to commence shortly
- Continued development of DFC/T, marine/diesel DFC power plant, and DFC/H<sub>2</sub> hydrogen generation plant.

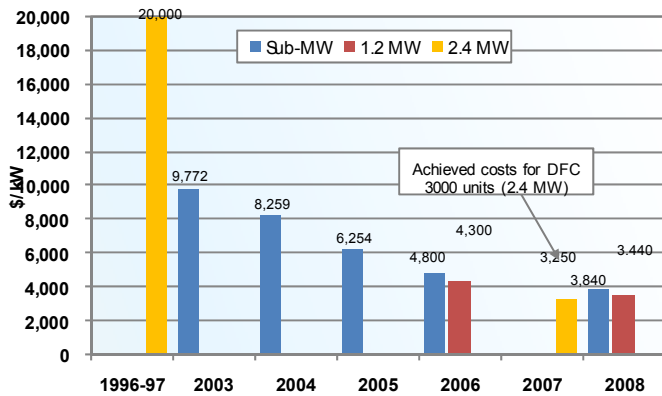

Figure 11. Cost reduction of FCE products (courtesy of FCE)

commercial fuel during early field trial program and 40% of all installations (including backlog) use or have used ADG.

FCE has moved its focus from product standardization to further product cost reduction,

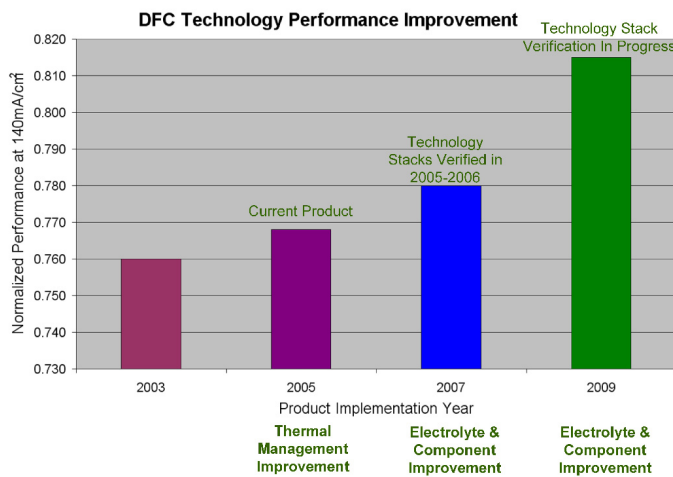

Figure 12. Performance improvement (courtesy of FCE)

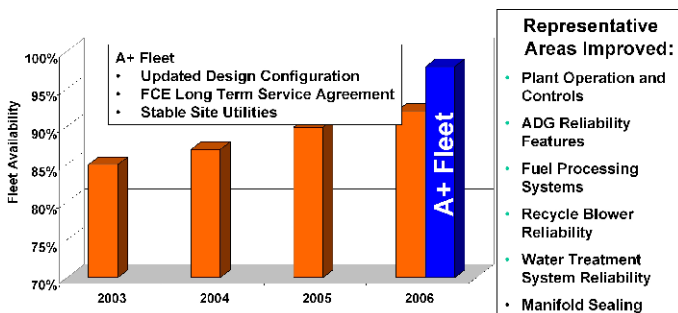

Figure 13. Availability of FCE systems fleets (courtesy of FCE)

It should be noted that, although FCE and CFC systems were originally developed for being operated on natural gas, other fuels (e.g. coal gas, propane, diesel, landfill, mine methane, biogas) were considered as optional feedstock. In particular, the use of anaerobic digester gas (ADG) emerged as an important

developing sustainable markets, organizational effectiveness, and continuous product improvement.

Figure 11 shows the cost reduction from 1996 to 2005 and the planned cost for 2007, while figure 12 shows the related performance improvement, which includes power density increase.

As capital cost reduction represents an important factor in the economical feasibility of a fuel cell system, O&M costs are also important factors that need to be further reduced.

An indication of O&M cost reduction is provided by figure 13, where the system availability

is depicted, and by figure 14, reporting the reduction of the fuel cell degradation rate from 1992 to 2004.

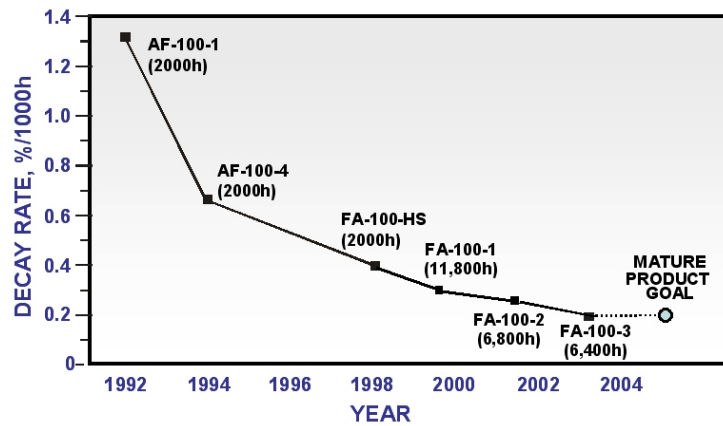

Figure 14. Fuel cell decay rate from 1992 to 2004 (courtesy of FCE)

### 3.2 Ansaldo Fuel Cells (Italy)

The demonstration program represents a key part of the present phase of development at AFCo. It mainly aims, through feedback from the field, at extending durability, reducing costs, simplifying manufacturing processes, improving availability and reliability. As shown in table 1, the whole program is expected to realize a number of different



Figure 15. AFCo's Hybrid MCFC-GT installation in Milan (courtesy of CESI Ricerche)

plants, both “Series 2TW” and “Series 1ST”. The final goal of the program is to demonstrate the technology viability for different fuels and applications, with a total power of over 4 MW. In addition to those reported in table 1, preliminary engineering design is on the way for power plants in the multi-MW class. Figure 15 depicts the hybrid MCFC/Gas turbine installation at the CESI Ricerca site in Milan, Italy.

Table 1. Demonstration program at Ansaldo Fuel Cells (courtesy of AFCo)

	<b>Size (Class)</b>	<b>Fuel</b>	<b>Site</b>	<b>Objectives</b>
First of a Kind	Series 2TW	Natural Gas	Guadalix, Spain	Twinstack® and MIR demonstration
WEAO Naval Application	Series 2TW	Diesel oil	Istanbul, Turkey	Diesel oil fuelled MCFC, demonstration plant
MCWAP Naval Application	Series 2TW	Marine diesel oil	On board	Test of onboard MCFC unit, design a multi-MW system for ship APU
Biomass Application	Series 1ST	Biomass gasification	Trisaia, Italy	Demonstration biomass gasification/MCFC integrated process
MOCAMI Hybrid Cycle	Series 1ST	Natural Gas	Milan, Italy	MCFC Integration with microturbine
Tecnodemo	Series 1ST	Natural Gas	Alessandria, Italy	MCFC demonstration facility
FISR-BICOCCA	Series 2TW	Syngas	Milan, Italy	CO <sub>2</sub> separation and management
BICEPS 1	MW class	Waste water ADG	Terni, Italy	Scaling-up with ADG
BICEPS 2	MW class	Landfill gas	Murcia, Spain	Scaling-up with landfill

AFCo's main achievements can be summarized as:

- Demonstrated sub-scale single stack system
- Demonstrated 500 kW systems (TWINSTACK®)
- Validated MCFC system and integrated components in hot pressurized vessel
- Validated Integration of stack-microturbine under static and dynamic conditions (hybrid cycle)
- Validation of control system, power conditioning and grid connection
- 20 000 hrs grid connected (Technodemo)
- Validated the use of alternative fuels (diesel oil, simulated coal gas, simulated biogas).

### 3.3 Ishikawajima-Harima Heavy Industries (Japan)

IHI MCFC technology was strongly supported by the Japanese New Energy and Industrial Technology Development Organization (NEDO), which started MCFC testing activity in 1984, with a 10 kW stack. Later, a 100 kW MCFC was successfully tested from 1987 to 1992. The results provided the feedback to realize the first Japanese 1 MW power plant, in Kawagoe, which operated for about 5000 hours, producing 2103 MWh.

For the short/mid-term, the goal is to operate a 7 MW MCFC/GT hybrid system, while the final goal is to replace large-size thermal power plants with MCFC-based ones.



Figure 16. MCFC operated on alternative fuels, at the 2005 Aichi Expo, Japan (courtesy of CRIEPI)

Fuel flexibility is another important aspect of the demo program in Japan. Recently, for the 2005 EXPO in Aichi, a hybrid MCFC-GT with nominal power of 300 kW, and a 250 kW MCFC system were installed both using fuels derived from waste (figure 16) and natural

gas. In particular, Chubu Electric powered the first unit on anaerobic digester gas produced from waste using a low temperature methane fermentation reactor. The second one was operated by Toyota Motors with gasified wooden waste and waste plastics.

The two MCFC systems were connected in a network of demonstration installations, including four Phosphoric Acid Fuel Cells (PAFC), each with a nominal power of 200 kW, a 50 kW Solid Oxide Fuel Cell (SOFC) system, and solar panels. Figure 17 depicts the contribution of the systems in satisfying the power requirements, in one particular day of the exposition.



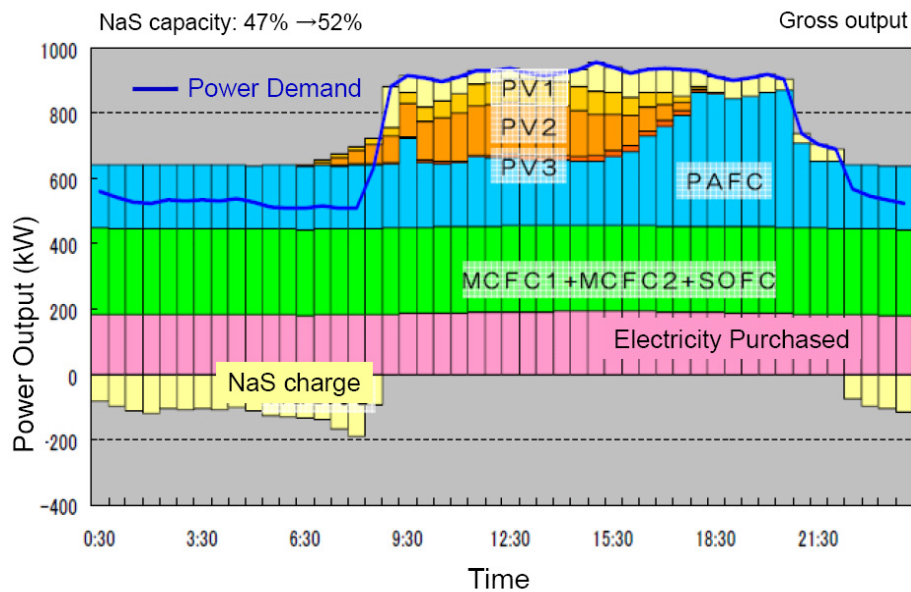

Figure 17. Power demand and power generation during the Aichi Expo (courtesy of CRIEPI)

Main IHI/NEDO plants results include:

- 1 MW, pilot plant realized in Kawagoe and operated for about 5000 hours, producing 2103 MWh
- Development of commercialization system focused on high reliability, compactness, and low cost.
- High performance stack realized (250 cells, 1 m<sup>2</sup> active area, >1.5 kW/ m<sup>2</sup>, 350 kW)
- 11 systems installed and operated, for a total of 2.1 MW
- Longest operational time 16 000 hours
- Realization of a 750 kW high performance module as building block for a MW scale plant (7-8 MW) is in progress
- Realized two 300 kW systems at the Aichi International Exposition, operated on digester gas produced from waste collected within the exhibition area
- Achieved 51% gross efficiency on Toyota Motor Corporation power plant during Aichi Expo.

### 3.4 KEPCO (KEPRI) and Posco Power (Korea)

The demonstration phase started in 1993, when a 25 kW stack was realized and tested. This successful phase was followed by tests of stacks of different sizes and system design and construction. Main plant results in Korea are:

- Realized and operated small-scale stacks (6, 7 and 25 kW, 75 kW)
- Realized and operated a 25 kW stack with high performance and long term operation, accumulated 4500 hours (ongoing) (pre-test for the 100 kW stack)
- Completed a 100 kW stack and system design
- Almost complete: system construction, stack fabrication, active component production, BOP fabrication
- 100 kW field tests planned for 2005-2008
- Complete system design for a 250 kW system and prototype of PCS.

POSCO, one of the top steel companies in the world and already a strategic partner of FuelCell Energy (FCE), has formed a partnership with KEPCO in August 2007 to develop and jointly market power plants incorporating fuel cell stack modules manufactured by FCE. POSCO will also provide a 2.4 megawatts (MW) power plant to KEPCO affiliate Korea South East Power Company (KOSEP) by next year, as a part of the aggregated 7.8 MW ordered by POSCO this year.

Under the agreement with POSCO announced in February, FuelCell Energy will continue to manufacture the core fuel cell modules, while POSCO will provide balance of plant equipment and system integration activities after completion of its manufacturing plant in 2008.

### 3.5 GenCell Corporation (USA)



Figure 18. GenCell's CHP-40 (courtesy of GenCell)

Commercial scale prototypes (40-125 kW) are being built and operated successfully. GenCell completed operation of a 40 kW unit at the University of Connecticut Campus. The following figure 18 depicts the system during the installation.

The system operated on natural gas and provided electricity to the Connecticut Global Fuel Cell Center of the University of Connecticut. GenCell is now starting up its third 40kW MCFC demonstration system.

#### **4. Potential customers and market**

The potential market for the current MCFC available products (i.e. in the power range of 40 kW-2 MW) exceeds the current manufacturing capacity, as reported in [6]. This fact is mainly due to the high cost and low durability of the systems, which prevents the technology from penetrating the market adequately. However, despite the cost and durability issues, at present, there are some niche markets of particular interest for early adoption of MCFC technology and for facing non-technical issues, such as conformity to regulation codes and standards. These applications include most of the Distributed Generation (DG) applications where by-product heat can be recovered in a Combined Heat and Power (CHP) configuration, including in the CHP definition the integration with a high temperature fed absorption cooler or a steam injection chiller. The high temperature outlet gas from the MCFC produces an increased coefficient of power compared with the presently used thermal coolers.

According to CFC Solutions [7], the revenues for cooling power are significantly higher than for heat, and the overlapping of heat and cooling power demands over a year enables a long annual operating time under full load, thus reducing the pay back period of the system.

CFC and FCE have installed most systems in CHP configuration; in particular hotels, university campuses and hospitals were found to be ideal candidates for first market introduction. An example of financial feasibility of a fuel cell-based network operating in CHP mode was performed by Colella et al. [8] for 200 kW Phosphoric Acid Fuel Cell (PAFC) systems. The results show the important role of thermal recovery in such applications.

Another point of interest for the early adoption of MCFCs consists in applications where by-products can be exploited as fuel and replace natural gas. As shown in table 1 and figure 10, there are systems installed or planned to be installed at wastewater treatment facilities, landfill sites, and breweries. Within the 5th Framework Programme (FP5), the European Commission funded the EFFECTIVE project, with two main objectives: 1) to develop gas processing units for upgrading biogas to MCFC quality requirements and 2) to run MCFC stacks at different locations (Germany, Spain, Austria and Slovakia) with different types of biogas (from landfill, waste water, agricultural and co-fermentation facilities). As a result of the project, an MCFC was operated on biogas for more than 15000 hours, thus demonstrating the technical feasibility of the system, and in particular of the fuel cell and of the clean-up system. During these fields operation, the stack achieved 50% of electrical efficiency [9-10].

An estimation of the potential market for fuel cells in the mid term is reported in table 2 [6]. In this study, MCFCs are considered in the range of 250 kW- 2 MW, which reflects most of the applications available today. As shown in table 2, in 2022 MCFCs could cover more than 15 GWe. Although the study considers an aggressive market penetration scenario, it does not take into account possible evolution of the technology towards multi-MW systems [1-3, 11].

Table 2. Market estimation of fuel cell systems [6]

<b>Technology size &amp; type</b>		<b>Potential capacity MW</b>			
		<i>5-10 kW PEM</i>	<i>200 kW PEM</i>	<i>200-250 kW SOFC</i>	<i>250-2000 kW MCFC</i>
<b>Year</b>					
2003		7	80	20	52
2007		12	166	118	192
2012		88	1262	893	1.464
2022		848	4.897	5.594	15.029

During the 1980s, several studies showed considerable potential of MCFCs in terms of high efficiency, low emission, and the possibility of separating CO<sub>2</sub> for the exploitation of clean coal.

In most cases, coal-based power plants have a rated power of the order of several hundreds of MW. Due to the large size of these power plants, no demonstration on real-scale of such systems has been realized, while the focus for most companies was the 100-500 kW range, based on natural gas. However, in recent years, after many technical issues have been solved, the option of employing MCFC for coal exploitation has regenerated much interest.

Ansaldo Fuel Cells is also stressing the interesting role that MCFCs could have in the short-mid term for CO<sub>2</sub> separation. As explained in Annex 1, the MCFC cathode requires a mixture of oxygen and CO<sub>2</sub>. The combination of these two gas species generates CO<sub>3</sub><sup>2-</sup> ions, which allows the operation of the fuel cell. As a consequence of this operation, CO<sub>2</sub> is continuously transferred from the cathode to the anode. This particular feature could be exploited for separating CO<sub>2</sub> originating from a traditional power or thermal power plant (figure 19).

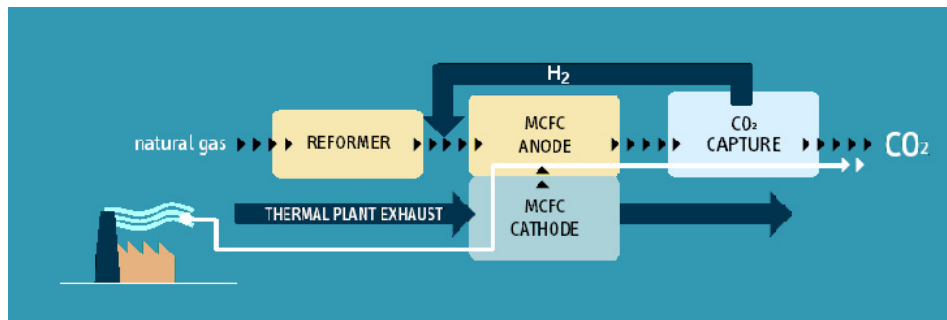

Figure 19. The MCFC as a CO<sub>2</sub> separator (courtesy of AFCo)

## 5. Concluding remarks

Molten Carbonate Fuel Cells have been demonstrated at several sites, and in different sizes. Focus is mostly on the 200 kW-1 MW range, while scale-up to multi-MW power plants are on the way. Investment cost and durability are still two important issues to be overcome, in order to ensure a proper market penetration. Therefore, R&D activities are strongly needed before the technology can be considered mature enough to compete with traditional energy systems.

However, there are interesting applications where MCFCs already make economical sense. These include applications where gas is available as a by-product of an industrial or agricultural process, and/or where Combined Heat and Power (CHP) configurations can be realized.

Among the number of fuels that MCFCs can employ, hydrogen represents an obvious option, however, at present there is no demonstration at full scale of a power plant operated exclusively on hydrogen. The reason for this is the lack of infrastructure, and the enduring high cost of hydrogen.

## Annex – MCFC technology explained

Most of the information presented in this section is derived from [27]. In the present annex, basic information on the technology is reported, in order to allow the reader to have a better understanding of MCFC technology, and its potential. For a detailed description of MCFC operating principles, and a comparison with Solid Oxide Fuel Cells, the reader is referred to [27].

### A1. General features

The typical structure of an MCFC is schematically illustrated in figure A1. The electrolyte is in the liquid and is embedded in a matrix. Ionic transfer inside the electrolyte is conducted via  $\text{CO}_3^{2-}$  ions migrating from the cathode to the anode side.

The chemical reactions that govern the operations are:



on the cathode side, while, on the anode:



Expression (A3) is commonly called a shift reaction and converts carbon monoxide and water into hydrogen. As a consequence of equations (A2)-(A3), water is formed in the anode side and  $\text{CO}_2$  is needed in the cathode side. Since the  $\text{CO}_2$  required for reaction (A1) is the same formed as consequence of reaction (A2), anodic gas is generally recycled from the anode to the cathode.

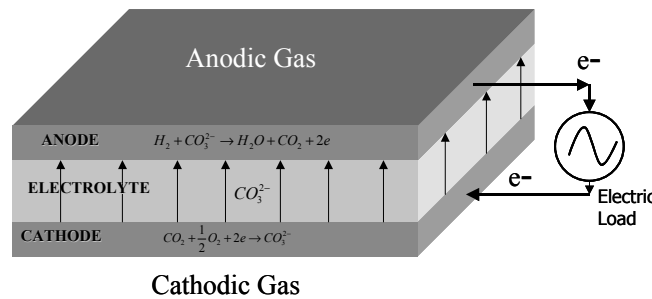

Figure A1. Schematic representation of a MCFC

The partial pressure of CO<sub>2</sub> is not necessarily the same in the cathode and in the anode, thus the Nernst equation, providing the ideal voltage, is the following:

$$E = E^0 + \frac{RT}{2F} \ln \frac{P_{H_2} P_{O_2}^{0.5} P_{CO_2, cathode}}{P_{H_2O} P_{CO_2, anode}} \quad (A4)$$

where  $E^0$  is the voltage at standard pressure,  $R$ ,  $T$ ,  $F$  are, respectively, the universal gas constant, the temperature and the Faraday constant, while  $P_i$  is the partial pressure of the  $i^{\text{th}}$  chemical species.

The stable electrolyte/gas interface in the electrodes is based on a capillary pressure balance [13, 14]. At thermodynamic equilibrium, the diameter of the largest pores that are flooded, is regulated by the following equation:

$$\frac{\gamma_c \cos \vartheta_c}{D_c} = \frac{\gamma_a \cos \vartheta_a}{D_a} = \frac{\gamma_e \cos \vartheta_e}{D_e} \quad (A5)$$

where  $\gamma$  is the interfacial surface tension,  $\vartheta$  is the contact angle of the electrolyte, and  $D$  is the diameter of the pores. The subscriptions  $c$ ,  $a$ ,  $e$  refer, respectively, to the cathode, anode and electrolyte matrix. All the pores with a diameter smaller than  $D$  are filled with the electrolyte, while the pores presenting a larger diameter, remain empty. The matrix pores present the smallest diameters, and are totally filled with the electrolyte, while the electrodes are partially filled, according to the pores diameter distribution.

## A2. Materials state of the art

The materials typically used for manufacturing an MCFC are: Nickel-Chromium or Nickel-Aluminum for the anode, NiO Lithiate for the cathode, Li<sub>2</sub>CO<sub>3</sub>/K<sub>2</sub>CO<sub>3</sub> for the electrolyte, and  $\langle$ -LiAlO<sub>2</sub> or  $\odot$ -LiAlO<sub>2</sub> for the matrix ([13, 15, 16]). In order to improve the cell performance and durability, as well the tolerance of some chemical substances, present in most of the fuels, alternative materials or particular treatment can be adopted. As an example, LiNi<sub>x</sub>Co<sub>1-x</sub>O<sub>2</sub> or coated nickel cathode can be considered as alternatives to the typical NiO Lithiate [17].

One of the most important problems that reduces MCFC longevity is the dissolution of the cathode in the electrolyte. NiO, in fact reacts with CO<sub>2</sub> in the cathode, according to the following reaction:





Nickel ions migrate through the matrix towards the anode, where they react with the incoming H<sub>2</sub>:



Besides cathode dissolution, another problem related to reactions (A6) and (A7) is that the resulting metallic nickel precipitates in the matrix, thus leading to short circuiting across the matrix. As can be noted from expression (A6), a way to reduce cathode solubility consists in decreasing the CO<sub>2</sub> partial pressure. CO<sub>2</sub> partial pressure depends on cathode operating pressure and cathodic gas composition:

$$P_{CO_2} = P_{cathode} \cdot X_{CO_2,cathode} \quad (A8)$$

(*X* represents the molar fraction) and so less durability is expected when the stack operates under pressurized conditions. Several studies have been conducted to assess NiO solubility, considering different electrolytes and cathodic gas compositions [18-21].

Various materials are also considered to replace NiO for cathode manufacturing; among them, LiFeO<sub>2</sub>, Li<sub>2</sub>MnO<sub>3</sub> and LiCoO<sub>2</sub> [22-24] were found to be more stable than NiO, but their relative performances are noticeably lower. Other possibilities are to reduce the electrolyte acidity, using particular additives, the performance of the FC is approximately the same for small percentages of additives such as CaCO<sub>3</sub>, SrCO<sub>3</sub>, BaCO<sub>3</sub> [13] or by substituting Li/K electrolyte mixtures with the Li/Na one, with the aim to find an acceptable compromise between low NiO solubility, ionic conductivity and low chemical aggressive behavior.

As extensively shown in the present study, one of the main advantages of MCFCs is that they can operate on a variety of different fuels, such as coal derived fuel, natural gas, gasified biomass, gasified waste, and landfill gas. While fuel flexibility is a great advantage for MCFCs, on the other hand, the poisoning effect of some chemical species contained in these fuels represents a primary issue. Since the most used fuel is currently natural gas, several investigations have been performed on the effect of sulfur on the anode and, consequently, on the entire fuel cell performance.

Other harmful substances are NH<sub>3</sub>, siloxane, chlorine and fluorine. Moreover, since the anodic gas is generally recycled to the cathode after catalytic combustion, the presence of NO<sub>x</sub> in the cathodic gas must also be considered [25].

Table A1. Summary of MCFC tolerance to impurities [26]

Contaminants	Tolerance limits
Sulphur (H <sub>2</sub> S)	0.1 - 5 ppm
Nitrogen compounds NH <sub>3</sub> NO <sub>x</sub>	No effects up to 1% 20 ppm
Halogens (HCl)	0.1-1 ppm
Alkali metals	1-10 ppm
Particulates (> 3 μm)	100 ppm

At the present, the effects of these impurities have been mostly quantified, but not completely understood at basic level. In table A1 some typical limit values, as well as the reference, are summarized [26].

### A3. Stack and balance of plant design

When realizing an MCFC stack or system, different technical solutions can be adopted. Each design choice presents its own advantages and disadvantages, and the appropriate choice is usually the result of an appropriate trade-off analysis. The most significant differences of MCFC systems regard:

- reforming process (internal or external)
- operating pressure
- manifolding configuration (internal or external).

Table A2 reports the main technical solutions chosen by each MCFC developer.

Table A2. Main design characteristics of MCFC industrial systems

	FCE	GenCell	CFC	AFCo	IHI	POSCO
<b>Manifolding</b>	External	Anode: int. Cathode: ext.	External	External	Internal	External
<b>Reforming</b>	Internal indirect	Internal indirect with ref. chamber in each cell	Internal	External	External	Internal indirect
<b>Operating Pressure</b>	Atm.	Atm.	Atm.	3.5 bar	1-12 bar	Atm.

### Internal or external reforming process

If the energy source is represented by conventional hydrocarbons, like natural gas, propane, gasoline etc, a reaction that transforms these into a hydrogen rich gas mixture is required. There are three main practices that are commonly used:

- Steam Reforming (SR)
- Partial Oxidation (POX)
- Autothermal Reforming (ATR).

The general hydrocarbon conversion reaction can be written in the following form [13]:

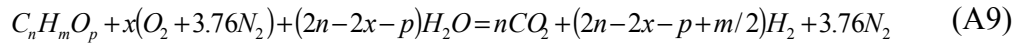

The amount of air used in the reaction, denoted with the  $x$  symbol, determines the minimum mole number of the required water, that is  $2n - 2x - p$ . In practice, the reaction is conducted with excess water to ensure the reaction and to avoid carbon deposition. When no air is used for the fuel conversion ( $x=0$ ), the process is Steam Reforming (SR), and is strongly endothermic. By increasing  $x$ , the reaction becomes less endothermic and, according to the selected hydrocarbon, there is a value of  $x$  that makes the reaction thermoneutral. In this case, the conversion process is commonly called Autothermal Reforming (ATR). When  $x=1$ , no water is needed for the reaction and the reaction is called Partial Oxidation (POX).

A straightforward thermodynamic consideration allows one to estimate which of the three processes can lead to the highest system efficiency. According to the first thermodynamic law (energy conservation), and ignoring the thermal losses (adiabatic reactor), in fact, if heat is provided, (i.e. the reaction is endothermic) the reformed gas presents an energy content that is higher than the unprocessed fuel. Since in a high temperature fuel cell system, the heat required for steam reforming is generally recycled from the fuel cell section, no additional fuel is required for the reforming reaction. This means that the more endothermic reaction (A9) is, the higher the energy content in the produced gas is, thus enhancing the system efficiency. When the fuel cell operates at low temperature, or when the fuel is externally processed and then delivered to the fuel cell system, the enhanced energy content of the reformed gas is paid by the combustion of additional fuel and so a system efficiency reduction is possible.

In the case of the ATR and POX, instead, no external heat is provided for the reforming reaction and, therefore, according to the first law, the system efficiency is expected to be lower than that of the SR.

For the reason explained above, and considering that for MCFC the required heat can be recovered from the cell itself, if the primary requirement is the realization of highly efficient systems, SR is chosen as the hydrocarbons processing reaction. For this reason, all MCFC developers chose SR as the reforming process.

The heat transfer between the fuel cell and the reforming section is substantially reduced if the reforming process takes place in the anode itself (internal reforming). In this case, in fact, the heat generated by the electrochemical oxidation of H<sub>2</sub> and CO is directly utilized for the reforming process. It should be stressed, however, that a complete internal reforming cannot be achieved, therefore a pre-reformer reactor, where a part of the initial fuel is converted, is needed.

Internal reforming can be conducted in a direct or indirect configuration. As illustrated in figure A2, in the case of Direct Internal Reforming (DIR), methane is converted into hydrogen inside the anode section, together with hydrogen oxidation. For Indirect Internal Reforming (IIR), instead, the reforming section is adjacent to the anode, but reforming reaction and H<sub>2</sub> and CO oxidation do not take place simultaneously.

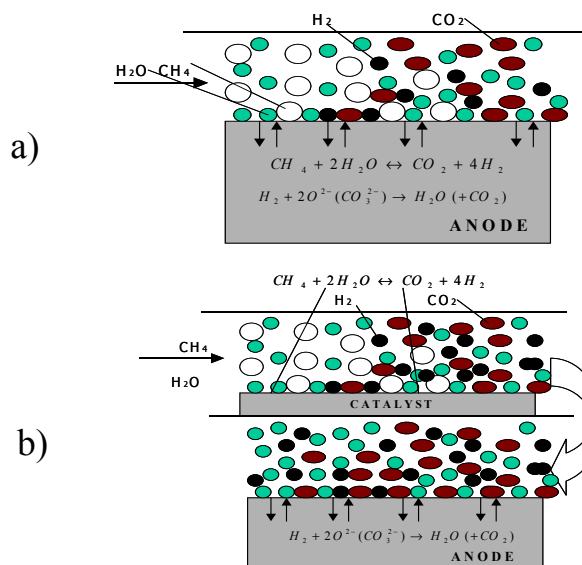

Figure A2. a) Methane Direct Internal Reforming (DIR);  
b) Methane Indirect Internal Reforming (IIR) [27]

This last solution is an intermediate situation between external and internal reforming. Indirect internal reforming, compared to direct, prevents overcooling effects at the anode inlet and allows for a high OCV, due to the higher partial pressure of H<sub>2</sub>. On the other hand, direct internal allows for a faster and easier reforming process. If methane is considered, in fact, the following reactions take place simultaneously:



As a consequence of hydrogen consumption and water production (A12), reaction (A11) is, in fact, driven to the right.

### *Pressurized and atmospheric conditions*

It is well known that pressurized conditions lead to performance enhancement [13]. Furthermore, pressurized conditions allow for the direct integration of a gas turbine as a bottoming cycle, which, in turn, is translated into a simple and relatively low cost system layout.

On the other hand, pressurized conditions lead to several disadvantages. First of all, the need of a pressurized vessel where the stack is embedded makes the system more complex and more difficult to control. In particular for MCFC, the pressure difference between the gas within the fuel cell and the surroundings (i.e. the pressure inside the vessel) needs to be minimal, in order to avoid fuel cell failure. Secondly, specifically for MCFC, the partial pressure of CO<sub>2</sub> is proportional to cathode dissolution, as explained in section A2.

Finally, it is important to bear in mind that when pressure increases, backward reaction of (A10) is favored, thus internal reforming should be limited to fuel cells operating at atmospheric conditions.

### Internal and external manifolding

Internal or external manifolding is referred to the way gas is delivered to the stack. figure A3 depicts an example of external and one of internal manifolding. In the first case (figure A3 a), anodic and cathodic gases are delivered to each single cell by means of an external manifold, which is in contact with one stack side. This solution typically implies a cross-flow configuration of the single cells.

In the second case (figure A3 b), each single cell housing has an embedded gas delivery system. This solution allows for more flexibility of the gas flow configuration (co-flow, counter-flow, cross-flow).



Figure A3 a. External manifolding configuration  
(courtesy of AFCo)

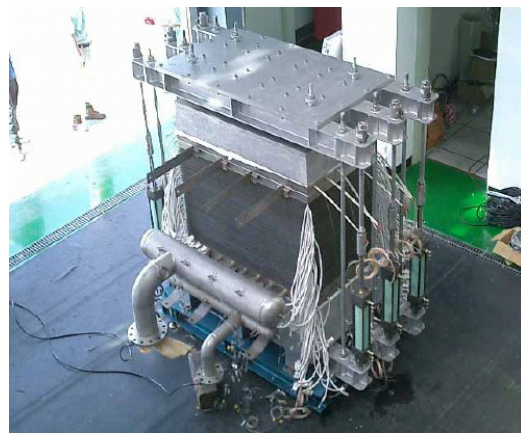

Figure A3 b. Internal manifolding configuration  
(courtesy of KEPRI)

## References

- [1] Marcenaro B. and Federici F., 2005. MCFC Fuel Cells Development at Ansaldo Fuel Cells. Proceedings of the. International Hydrogen Energy Congress and Exhibition (ICHET 2005), 13-15 July, 2005, Istanbul, Turkey.
- [2] Ghezel-Ayagh H., Walzak J., Patel D., Daly J., Maru H., Sanderson R. and Livingood W., 2005. State of direct fuel cell/turbine systems development. Journal of Power Sources, Volume 152, pp. 219-225
- [3] Tooi M., 2005. Development of Molten Carbonate Fuel Cell in Japan. Proceedings of 2005 Fuel Cell Seminar, November 14-18, 2005, Plam Spring, CA.
- [4] Cropper M., 2003 “Fuel Cell Market Survey, large Stationary Applications” Survey report downloadable from [www.fuelcelltoday.com](http://www.fuelcelltoday.com)
- [5] Adamson, K.-A., 2007. Fuel Cell Today Market Survey: Large Stationary Applications 2007. Survey report downloadable from [www.fuelcelltoday.com](http://www.fuelcelltoday.com)
- [6] Anna Monis Shipley, R. Neal Elliott, 2004. “Stationary fuel cells: future promise, current hype” ACEEE Report number IE041
- [7] Personal communication with G. Huppmann, CFC Solutions.
- [8] Colella, W., Niemoth, C., Lim, C., Hein, A., “Evaluation of the Financial and Environmental Feasibility of a Network of Distributed 200 kWe Cogenerative Fuel Cell Systems on the Stanford University Campus,” Fuel Cells – From Fundamentals to Systems, 1, 148-166, Feb. 2005.
- [9] Trogisch S., Hoffmann J. and Daza Bertrand L., 2005. Operation of molten carbonate fuel cells with different biogas sources: A challenging approach for field trials Journal of Power Sources, Volume 145, Issue 2, pp. 632-638.
- [10] Trogish, S., Baaske, W. E. (eds), 2004. Biogas Powered Fuel Cells. Trauner Verlag, Linz, Austria.
- [11] Farooque M. and Maru H.C., 2006. Carbonate fuel cells: Milliwatts to megawatts. Journal of Power Sources 160, pp. 827–834.
- [12] Bove R., Lunghi P., Lutazi A. and Sammes N. M. (2004) Biogas as fuel for a fuel cell system: investigation and first experimental results for a molten carbonate fuel cell. Accepted for publication on ASME Fuel Cell Science and Technology.
- [13] Hirschenhofer J.H. et al. (2002) Fuel cell handbook, sixth edition, US Department of Energy.
- [14] Larinne J. and Dicks A. (2000) Fuel Cell Systems Explained. Wiley and Sons, UK.
- [15] Carrette L., Friedrich K. A. and Stimming U. (2001) Fuel Cells-fundamentals and applications. Fuel Cells from Fundamental to Systems 1, 1, 5-39.
- [16] Lunghi P. and Bove R. (2003) Life Cycle Assessment of a Molten Carbonate Fuel Cell Stack. Fuel Cells from Fundamental to Systems 3, 4, 224-230.

- [17] Colonmer H., Ganesan P. and Subramanian (2002) Optimization of the cathode long-term stability in molten carbonate fuel cells: experimental study and mathematical modeling. Final Report submitted to US DOE. DOE Award number DE-AC26-99FT40714.
- [18] M. S. and Selman J. R. (1998) Dissolution of partially immersed nickel during in situ oxidation in molten carbonate: cycling, stripping and square wave voltammetry measurements. *Journal of Electroanalytical Chemistry* 457, 89-97.
- [19] Peelen W. H., Hemmes K. and de Wit J. H. (1997) Diffusion constants and solubility values of  $\text{CO}_2^+$  and  $\text{Ni}^{2+}$  in Li/Na and Li/K carbonate melts. *Electrochemical Acta* 42, 15, 2389-2397.
- [20] Ota K., Takeishi Y., Shibata S., Yoshitake H., Kamiya N., Yamazaki N. (1995) Solubility of cobalt oxide in molten carbonate. *Journal of Electrochemical Society* 142, 10, 3322.
- [21] Baumgartner C. E. (1984) NiO solubility in molten Li/K carbonate under molten carbonate fuel cell cathode environment. *Journal of Electrochemical Society* 131, 8, 1850.
- [22] Lundblad A., Schwartz S. and Bergman B. (2000) Effects of sintering procedures in development of LiCoO<sub>2</sub>-cathodes for the molten carbonate fuel cell. *Journal of Power Sources* 90, 224-230.
- [23] Giorgi L., Carewska M., Patriarca M., Scaccia S., Simonetti E. and Di Bartolomeo A. (1994) Development and characterization of novel cathode materials for molten carbonate fuel cell. *Journal of Power Sources* 49, 1-3, 227-243.
- [24] Veldhuis J. B.J., Eckes F.C. and Plomp L. (1992) The dissolution properties of LiCoO<sub>2</sub> in molten 62:38 mole percent Li:K carbonate. *Journal of Electrochemical Society* 139, 1, L6.
- [25] Kawase M., Mugikura Y., Watanabe T., Hiraga Y., Hujihara T (2002) Effects of NH<sub>3</sub> and NO<sub>x</sub> on the performance of MCFCs. *Journal Power Sources* 104, 265-271.
- [26] Desideri U., Lunghi P. and Burzacca R. (2002) State of the art about the effects of impurities on MCFCs and pointing out of additional research for alternative fuel utilization. Proceedings of 1st International Conference of Fuel Cell Science, Engineering and Technology, April 21-23, 2003, Rochester, NY, USA.
- [27] Moreno A., Bove R., Lunghi P. and Sammes N. M., 2005. High temperature fuel cells. Chapter 18 of the book: "Biofuels for Fuel Cells: Biomass Fermentation Towards Usage in Fuel Cells", IWA Publishing, London, UK. Edited by P. Liens, P. Westermann, M. Haberbauer and A. Moreno.
- [28] DoD (2004) Department of Defense/ Fuel cell/ERDC-CERL Programs, website: <http://www.dodfuelcell.com>
- [29] DoE (1998) Landfill gas clean up for molten carbonate fuel power generation. US Department of Energy and Electric Power Research Institute, Final Report CRADAMC95-031.
- [30] EPA (2004) Database of Landfills and Energy Projects, downloadable on <http://www.epa.gov/lmop/index.htm>



Published by ENEA  
Communication Unit  
Lungotevere Thaon di Revel, 76 – 00196 Rome  
*www.enea.it*

Editing: Giuliano Ghisu  
Printed by Primaprint (Viterbo) - April 2008



IEA ADVANCED Fuel Cells

[www.leafuelcell.com](http://www.leafuelcell.com)



Italian National Agency for  
New Technologies, Energy  
and the Environment

[www.enea.it](http://www.enea.it)



FuelCell Energy

[www.fuelcellenergy.com](http://www.fuelcellenergy.com)

CFC Solutions

[www.cfc-solutions.com](http://www.cfc-solutions.com)



Ansaldo Fuel Cells  
A Finmeccanica Company

[www.ansaldofuelcells.com](http://www.ansaldofuelcells.com)



[www.kist.re.kr/en](http://www.kist.re.kr/en)



[www.nedo.go.jp/english](http://www.nedo.go.jp/english)



[www.gencellcorp.com](http://www.gencellcorp.com)