



Ricerca di Sistema elettrico

# Rapporto finale sulla realizzazione e commissioning dell'impianto Lifus 6 per lo studio dei fenomeni di erosione/corrosione

P. Favuzza, G. Fasano, S. Mannori,  
M. Tarantino, A. Tincani

RAPPORTO FINALE SULLA REALIZZAZIONE E COMMISSIONING DELL'IMPIANTO LIFUS 6 PER LO STUDIO DEI FENOMENI DI EROSIONE/CORROSIONE

P. Favuzza, G. Fasano, S. Mannori, M. Tarantino, A. Tincani (ENEA)

Settembre 2014

Report Ricerca di Sistema Elettrico

Accordo di Programma Ministero dello Sviluppo Economico – ENEA

Piano Annuale di Realizzazione 2013

Area: Produzione di Energia Elettrica e Protezione dell'Ambiente

Progetto: Attività di fisica della Fusione complementari a ITER

Obiettivo: Campagne sperimentali a breve-medio termine (2000/4000 ore) per corrosione/erosione da litio

Responsabile del Progetto: Aldo Pizzuto, ENEA

## Index

SUMMARY .....	4
1 INTRODUCTION .....	5
2 DESCRIPTION OF ACTIVITIES AND RESULTS .....	5
2.1 FINAL DESIGN OF LIFUS 6 PLANT .....	5
2.2 INSTALLATION OF THE HOT TRAP AND ITS DEDICATED SAMPLER.....	5
2.3 INSTALLATION OF ALL THE AUXILIARY COMPONENTS AND INSTRUMENTATIONS .....	7
2.4 COMPLETION AND CHECK OF LIFUS 6 HARDWARE.....	9
2.5 REALIZATION OF A SAFETY STRUCTURE AROUND LIFUS 6 PLANT .....	10
2.6 INSTALLATION OF VIDEO CAMERAS AROUND LIFUS 6 PLANT.....	12
2.7 DATA ACQUISITION AND CONTROL SYSTEM (DACs) .....	13
2.8 LIFUS 6 BLANK TESTS .....	13
2.8.1 <i>Phase I: individual tests</i> .....	13
2.8.2 <i>Phase II: argon washing and burn-in up to 250°C.</i> .....	16
3 CONCLUSIONS .....	17
4 REFERENCES .....	18
5 ABBREVIATIONS AND ACRONYMS .....	18

## Summary

This report deals with the completion of Lifus 6 plant realization, a plant aimed at investigating the corrosion/erosion resistance of Reduce Activation Ferritic Martensitic Steels (RAFM) when exposed to flowing liquid Lithium, in the frame of the IFMIF project.

This plant, whose design and skeleton construction had been already attained during the previous years in ENEA Brasimone research centre, has been completed with the installation of all the Lithium purification devices, the auxiliary components (valves, gas lines, filters, heating cables, electrical wires...) and the sensors (thermocouples, pressure transmitters....) to online monitor all the operating parameters. A specific control software has been created to manage, from a remote computer, the huge number of input/output signals to/from the plant; much care has been also taken in facing all the strict safety regulations and implementing the related procedures. All the elements have been individually checked for their functioning; a long time test of the overall plant filled with Argon up to 250°C has been performed as well, highlighting no kind of failing.

Lifus 6 erosion/corrosion tests are going to start in the next weeks, as soon as the Italian Fire Department will provide its formal authorization, certifying the plant complies with the required safety regulations.

## 1 Introduction

In the framework of the EVEDA phase of the IFMIF Project, which is part of the Broader Approach, ENEA has been assigned by F4E to carry out the Procurement Arrangements (PAs) LF03 and LF04-EU. The purpose of the ENEA experimentation is to measure the erosion/corrosion resistance of Eurofer 97 and F82H, which are Reduce Activation Ferritic Martensitic Steels (RAFM) considered as candidate structural materials for the IFMIF facility, when exposed to liquid Lithium flowing at 350°C at a speed of 15 m/s and containing small concentrations of non-metallic impurities. This task hence entails: from one side to design and construct a dedicated flowing Lithium loop, integrating a test section where the investigated materials specimens can be inserted (which is the specific goal of the LF03 PA); from the other side, to implement in the same plant a purification system, aimed at reducing non metallic concentrations in Lithium below fixed values, particularly Nitrogen which must be kept below 30 wppm, and monitoring them (which is the specific goal of the LF04-EU PA).

The fulfillment of this task has led, during the previous year, to the basic realization in ENEA Brasimone Centre of the Lifus 6 plant, as described in Rds/2013/124 [1]. This report deals instead with the additional work done during last year on Lifus 6 plant in order to achieve its final completion, its remote control and its usability in safe conditions for the coming soon experimentation.

## 2 Description of activities and results

### 2.1 Final design of Lifus 6 plant

Figure 1 shows the final 3D design of Lifus 6 plant. Compared with the 3D design shown in [1], some difference is evident: the introduction of the two Air Coolers, for cooling the Lithium both downstream of the electromagnetic pump and upstream of the Cold Trap; the addition of the connection pipe between the Storage Tank and the Hot Trap; the sampler directly connected to the top of the Hot Trap (sampler 2); some minor spatial changes to take into account a different positioning of the inlet/outlet pipes to the electromagnetic pump.

### 2.2 Installation of the Hot Trap and its dedicated sampler

All the purification elements and devices, which had been already separately realized, have been installed in Lifus 6 plant. Particularly, for what concerns the Hot Trap, aimed at Lithium purification from Nitrogen impurities in static conditions [1-3], after the construction it has internally accommodated the metallic lid hamper for the getter (figure 2-A); about 10 kg of commercial Titanium sponge getter in chunks (from *Sigma-Aldrich*; product code:268526) have been then put inside the internal hamper, after creating an Argon atmosphere to minimize the getter exposure to air (see teflon pipe in figure 2-B, which introduces Argon). After closing the hamper and locating the gasket in its seat (figure 2-C), the Hot Trap has been finally closed (figure 2-D) and its installation completed, by linking it to the Lithium Storage Tank (see figure 3).

Finally, the second sampler (“mushroom” shape) has been installed, connecting it directly to the top of the Hot Trap (figure 4), to immediately assess the efficiency of a just performed purification without having to refill all Lifus 6 plant with Lithium.

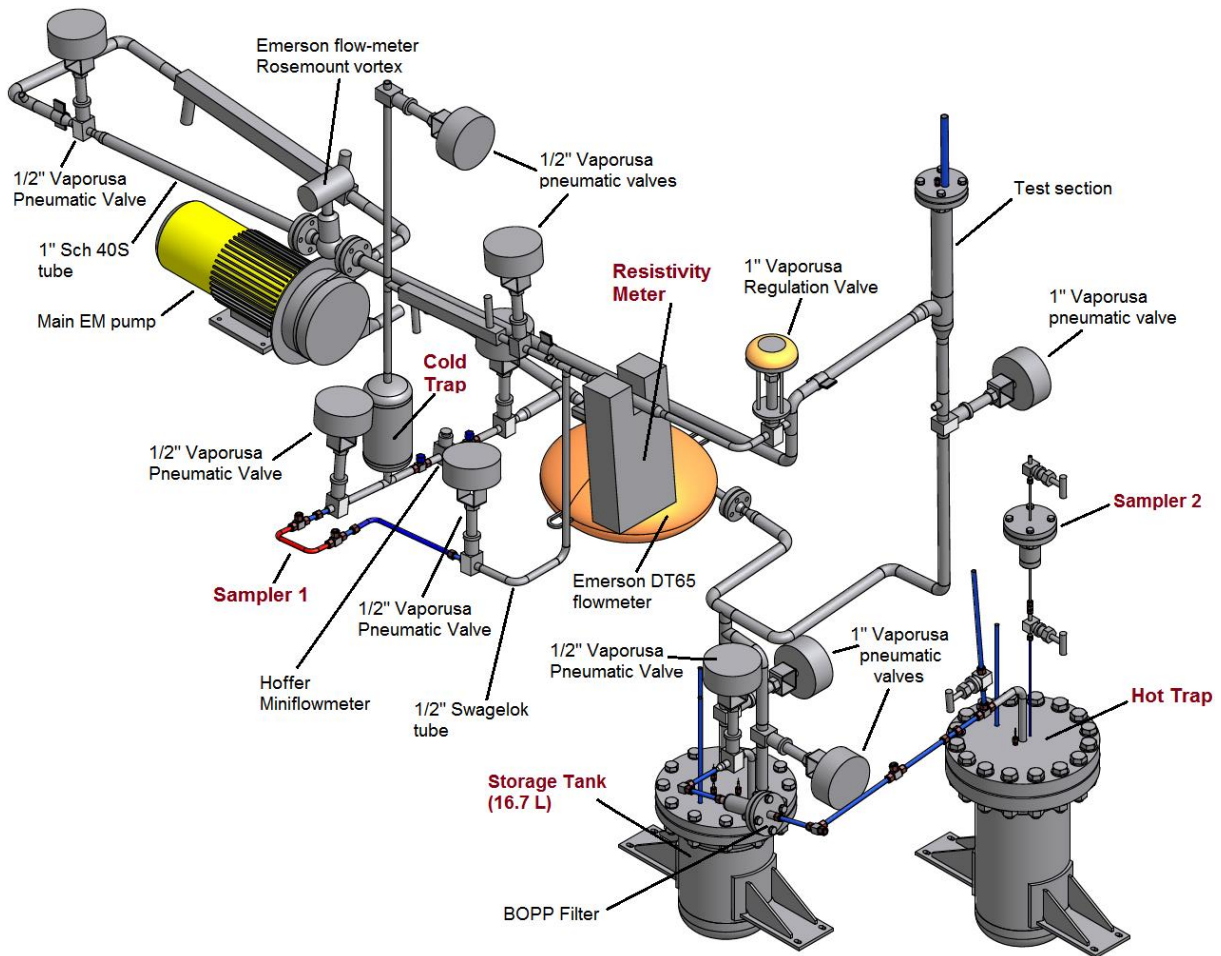

Figure 1: 3D view of the final design of Lifus 6 plant

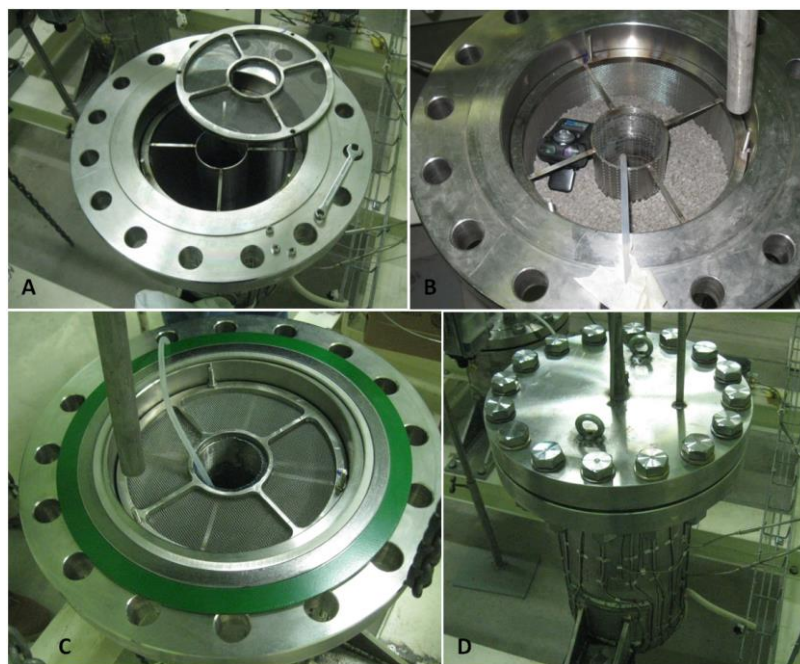

Figure 2: A: empty (and open) Hot Trap, with the hamper inside; B: open Hot Trap, with the getter filling the internal hamper; C: Hot Trap, ready to be closed; D: closed Hot Trap



**Figure 3: final installation of the Hot Trap inside Lifus 6. 1: Hot Trap; 2: Storage Tank; 3: Pipe connecting the Hot Trap and the Storage Tank; 4: Pneumatic valves**



**Figure 4: the sampler installed on the top of the Hot Trap. 1: sampler; 2: connecting pipe to the Hot Trap; 3: pressure gauge for the measurement of the pressure in the below Hot Trap**

### **2.3 Installation of all the auxiliary components and instrumentations**

ENEA has prepared and installed all the supporting and hanging systems for the main components of the loop (figure 5, left); antivibrations bearings have been installed as well, in correspondance of the high speed rotation elements, like the electromagnetic pump and the aircoolers rotors (figure 5, right).

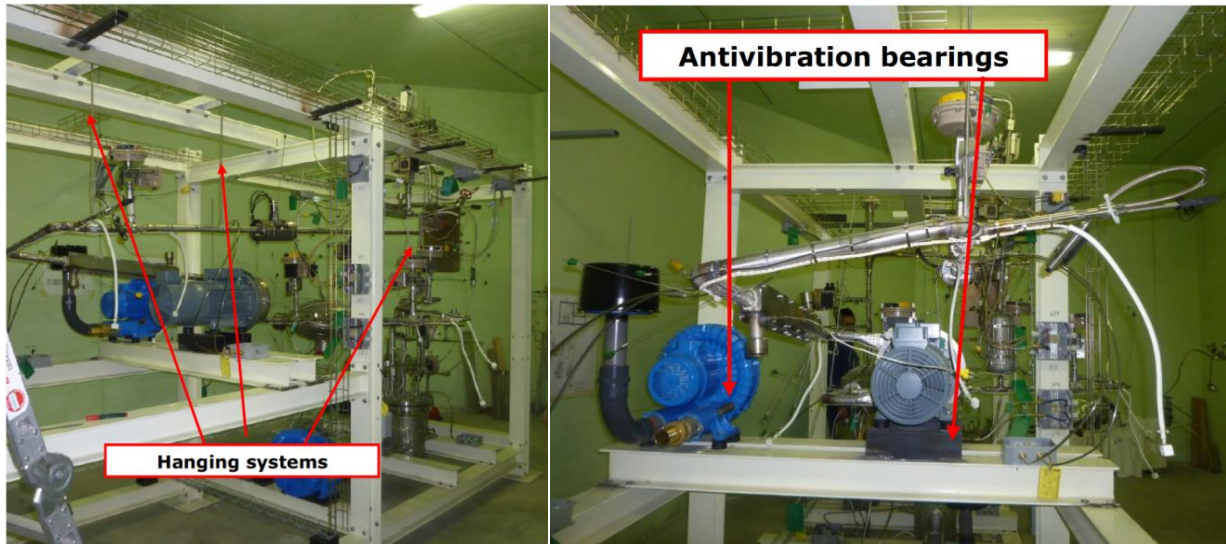

Figure 5: Left: hanging systems; right: antivibration bearings

Then the following gauges have been installed:

- 3 level sensors on the storage tank;
- 2 level sensors on the test section;
- 1 level sensor on the Hot Trap;
- 2 pressure transmitters on main loop;
- 1 pressure transmitter in the purification line (see figure 6).



Figure 6: Pressure Transmitters. Left: EM pump outlet and purification line; right: Test Section outlet

At the same time, ENEA workshop has realized the external jackets (swept by a controlled flow of air for the heat removal) of the two Air Coolers (figure 7, left). All the heating cables, thermocouples and Lithium leak sensors have been installed on the loop; the Lithium leak basins for the flanged connections of the Vortex and Coriolis flow meters have been constructed and mounted as well (figure 7, right).



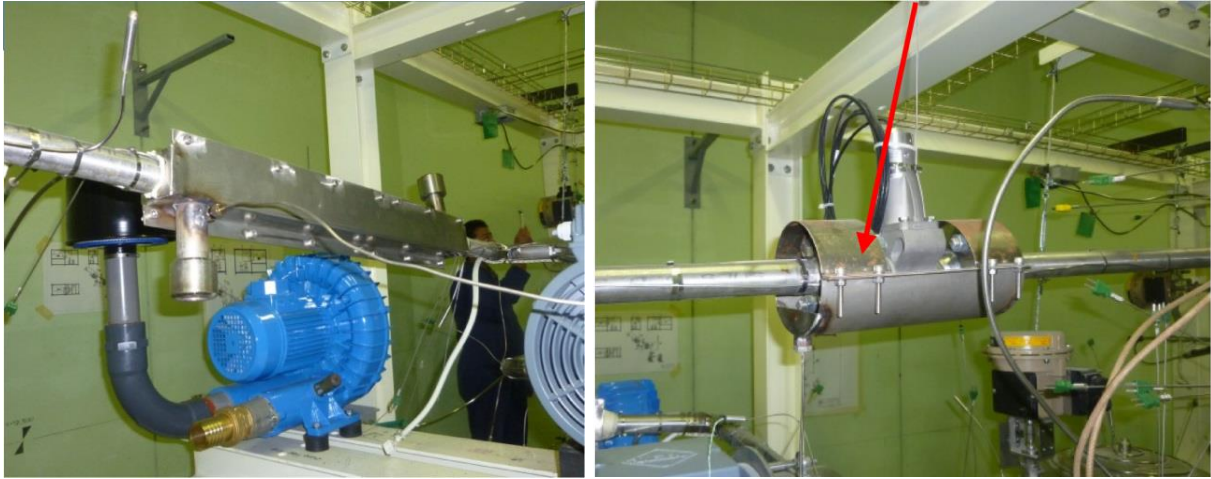
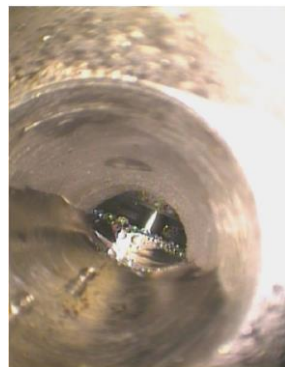

**Figure 7: left: main loop Aircooler (3 kW); right: Lithium leak basin**

#### **2.4 Completion and check of Lifus 6 hardware**

The loop has been then internally “washed” with demineralized water in order to remove residues of machining (grinding of welding points). During this phase, the internal volume of the loop has been experimentally verified as 9.63 L: 5.80 L for the main loop and 3.83 L for the purification loop, Cold Trap included.

ENEA has also performed draining tests of the different lines with water and gas (Argon) and checked the correct operation of the facility valves. During draining tests, flow problems occurred. Thus ENEA carried out endoscopic checks and found that two valves were wrong (figure 8). These valves were removed and substituted. After replacing the valves, ENEA has performed the mechanical tightening of all the flanges and Swagelok fittings in order to carry out the pressure test (Argon at 0.6 MPa, room temperature, 1 hour) and the leak test (Argon at 0.6 MPa, room temperature, 24 hour). Both tests were successful.



**Figure 8: Endoscopic photo at the inlet of one of the substituted valve**

Finally, all the loop has been thermally insulated (figure 9), thanks to the support of the *Alfec s.r.l.* company (italian private company).

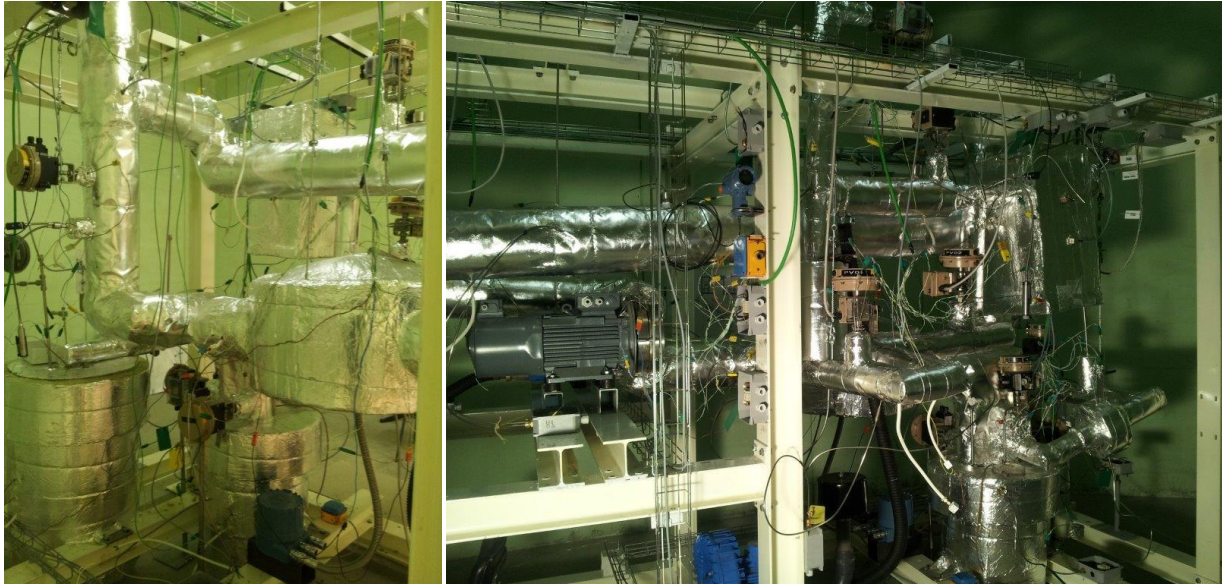

Figure 9: final appearance of Lifus 6, after the completion of the thermal insulation, from 2 different angles

### 2.5 Realization of a safety structure around Lifus 6 plant

A specific containment of the whole plant has been realized, together with an efficient fire extinguishing system, in collaboration with two private Italian companies (*Alfec, Bettati Antincendio s.r.l.*).

The plant is now completely confined inside a metallic box in AISI 304 (4600 x 2500 x 3150 mm), which creates an hermetically closed environment around the plant (figure 10, left). The plant is not accessible to anyone: limited accessibility is allowed only at the moment of sampling (sampler substitution), specimens insertion/removal in the test section or for required maintenance, by unscrewing specific panels mounted in correspondence of the replaceable parts. The plant is therefore hidden to the observer, as shown in figure 10 right.

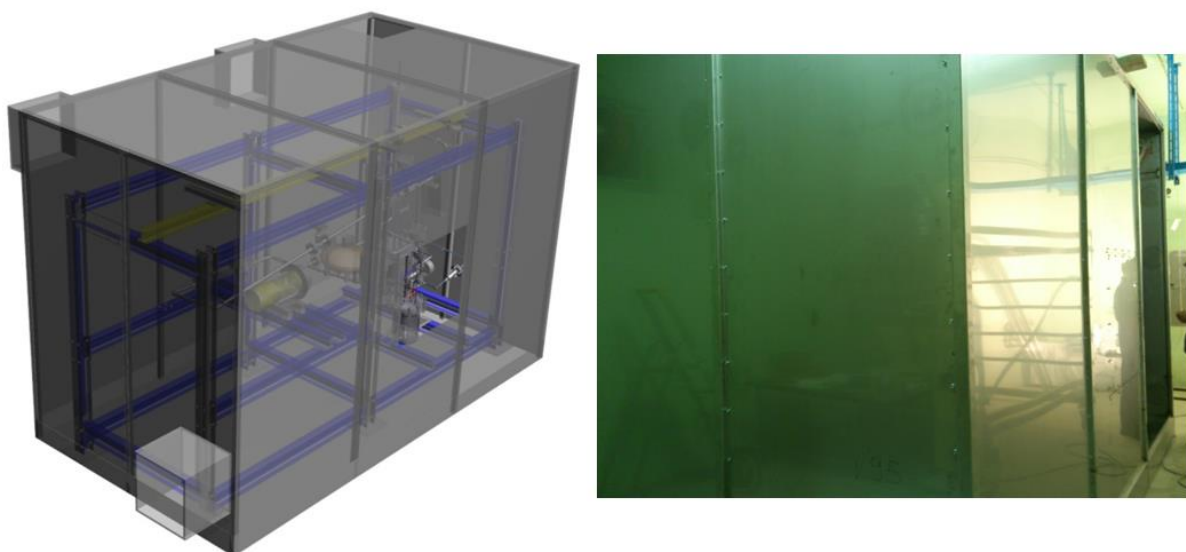

Figure 10: left: 3D design of the safety box, around Lifus 6 plant; right: safety box around Lifus 6 plant, seen from outside (last panel, on the right, still to be installed)

Four smoke detectors have been installed inside this environment (figure 11, left), in order to fast identify the presence of gaseous products produced by abnormal reactions in the atmosphere, as in case of Lithium ignition. These smoke detectors are connected to a dedicated control panel, located in the external hall (see figure 11, right), which operates autonomously, not depending from the overall Lifus 6 control software, even if its status signals can be read by the Data Acquisition and Control System (DACS) of the plant.



**Figure 11: left: inner view of part of the top of the containment box (1: one of the four smoke detectors; 2: one of the two Argon injectors); right: dedicated control panel of the fire extinguishing system**

The fire extinguishing control system has three different status:

- NO FAULT, when the system is properly functioning;
- PREALARM, when one of the smoke sensors has detected an abnormal situation. This status is accompanied by a specific acoustic emission. If the abnormal situation is not resolved, after 30 seconds the system go to:
- ALARM. The control panel triggers the fire extinguishing procedure, by flooding all the internal environment around Lifus 6 with high pressure Argon (stored in two 150L 200 bar dedicated cylinders in the external hall - see figure 12), through two gas injectors (figure 11, left) on the top horizontal panel (roof) of the containment box. This way the air concentration in the box is lowered in few time below 4%. The ALARM signal is at the same time sent to the Lifus 6 control system, which automatically activates the draining of Lithium from the loop in the storage tank.



**Figure 12: Dedicated high pressure Argon cylinders for the fast injection in the safety box**

In parallel with the realization of the containment box, the evaluation of all the risk factors associated to the plant operation and maintenance has been conducted and has led to the editing of all the documents required by the Italian Fire Department to produce the related certification. The documents are still under revision: as soon as the formal authorization will be released by the Fire Department, it will be possible to start with Lifus 6 experimentation.

## 2.6 Installation of video cameras around Lifus 6 plant

Even if the plant is excluded to the eyes, it is however observable and visually monitored through the employment of four motorized, remotely controlled, video cameras, equipped with infrared sensors to overcome also poor light conditions. Figure 13 is a screenshot of a remote computer visualizing the contemporary output of the four cameras. The cameras on the top of the picture (CAM1 and CAM2) are mounted inside the safety box and show Lifus 6 components, from two opposite angles; CAM3 shows Lifus 6 room, normally not accessed during plant operations; CAM4 shows instead Lifus 6 external hall, separated from the previous room by an antifire door, holding the plant electrical panels and the fire extinguishing control system. Also this hall is excluded to the operator, during operations, since Lifus 6 control software is operated from a computer located in a farther, dedicated room.



Figure 13: contemporary output of the four video cameras, as seen from a remote PC.

## 2.7 Data Acquisition and Control System (DACS)

During the last year, all the electrical connections and cabinets necessary for the acquisition of data from the plant and for its control have been realized. Figure 14 shows these cabinets: Q1 holds the ON/OFF and proportional heaters (32 channels); Q2: Power distribution and control and inverters; Q3: National Instruments DACS modules; Q4: Resistivity Meter and auxiliary components; Q5: Resistance Temperature Detectors (RTD) and Thermocouples (TC) modules. The cabinet (Q1-Q4) are located in the experimental hall, while Q5 is installed near the sensors.

The system is based on National Instruments products; the loop can be remotely controlled connecting the PLC via a standard TCP-IP address to a PC Workstation, present in the control room. Moreover, as happens on all PLC systems, in case of loss of network connection the system will maintain the last safe configuration set with a full management of abnormal situations and alarm. According to the changes introduced by the Design Review at the beginning of 2013, the Control and Acquisition System of the loop is also able to control the EM pump and the fans of the two air-coolers.

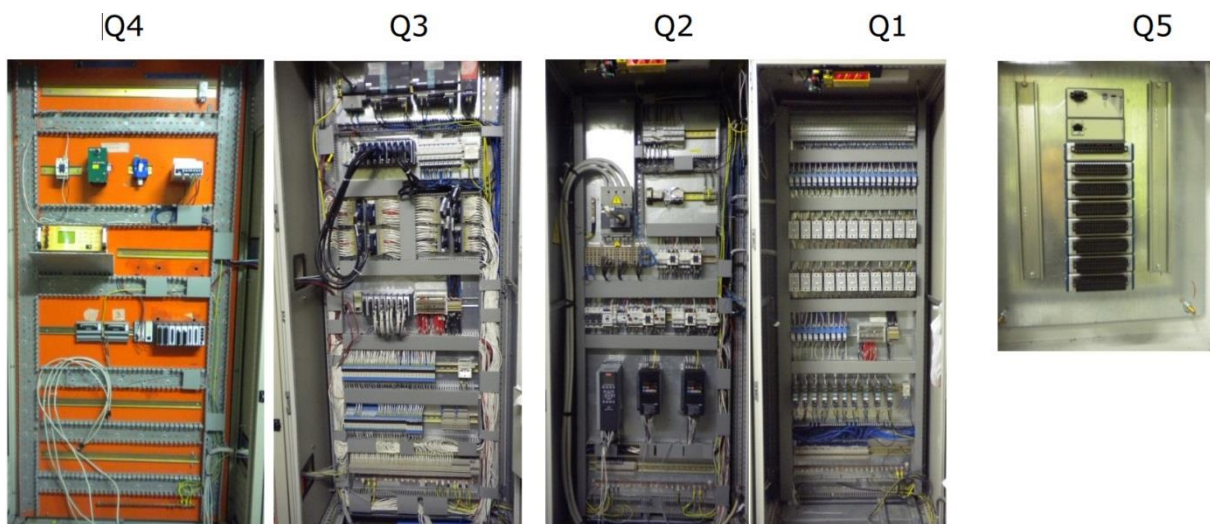

Figure 14: Lifus 6 electrical cabinets.

## 2.8 Lifus 6 blank tests

After the accomplishment of all the electrical connections installation, Lifus 6 plant has been entirely checked for the functioning of its elements (thermocouples, heating elements, sensors, valves....). Some of them have been replaced and some minor modifications have been introduced in order to optimize the functioning of the plant. The final version of *Lifus 6 P&ID*, after this check-up phase, is shown in figure 15. A brief descriptions of the performed tests is reported in the following subsections.

### 2.8.1 Phase I: individual tests

Lifus 6 Data Acquisition and Control System manages more than 300 input and more than 100 output signals. Using a first software version (v. 0.1), each signal has been individually tested along the complete hardware and software path. The individual testing procedure has been applied to all Lifus 6 components and subsystems. The procedure has started at the beginning of May and ended in the first half of June 2014: its basic philosophy is highlighted by some examples of component testing below reported.



### Thermocouple input test

Most of the thermocouple temperature sensors are installed on the external surface of the pipes. The testing procedure has verified:

1. the good contact between the sensor and the pipe;
2. the electrical cabling to the measurement box;
3. the correct assignment of the physical input channel to the logical variable inside the software;
4. the correct visualization of the variable on the user interface.

Testing points 2 to 4 are straightforward. Check #1 has been done at ambient temperature and heating the pipe where the thermocouple is installed.

### Leakage detector input test

Lithium leakage is detected using a ceramic insulated probe installed in a critical zone of the plant (e.g. near each valve, as, for example, LKG / LK 16 shown in Figure 16). Liquid lithium is a very good electrical conductor, therefore any leakage will close the circuit to ground.

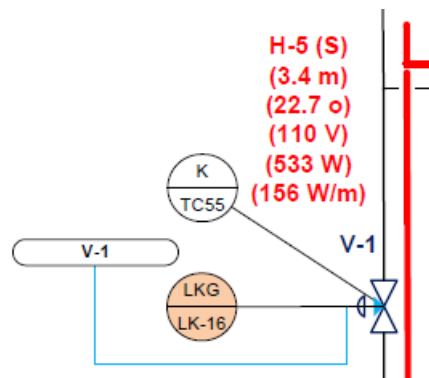

**Figure 16: LKG / LK16 leakage sensor, in correspondence of V-1 valve**

The electrical signal is not sent directly to the National Instruments PLC but crosses an electro-mechanical relays. The relays works as ground separator (breaks any ground current loop), as electrical noise filter (the time constant of the relays is around 20 milliseconds) and as threshold detector (the minimum current is around 10 mA). The combination of these three effects assures a very good electrical noise immunity, therefore minimizes false lithium leakage alarms.

The testing procedure has verified:

1. the electrical insulation between the probe and the plant;
2. the connection of the electrical cable to the junction box;
3. the connection between the junction box and the relays;
4. the connection between the relays;
5. the correct assignment of the physical input channel to the logical variable inside the software;
6. the correct visualization of the variable on the user interface.

Each step has been individually checked visually and using electronic instruments. Finally, each leakage detector has been individually tested, simulating the leakage by manually closing the sensing probe to the plant ground.

### Lithium valve test

The valves which regulate the circulation of liquid Lithium inside the plant are pneumatically actuated and electrically controlled. The control signal is a 0-24 V direct current signal. A relais drives the electromagnetic coil inside the valve. The coil drives a pneumatic amplifier and, finally, the air pressure moves the valve stem.

The testing procedure has verified:

1. the correct assignment of the logical variable inside the software to the physical output line;
2. the connection between the output line and the relais;
3. the connection of the relais to the junction box inside the electrical cabinet;
4. the electrical connection from the electrical cabinet junction box to the plant junction box;
5. the connection between the plant junction box and the valve;
6. the connection of the valve position sensing signals to the plant junction box;
7. the connection between the plant junction box and the electrical cabinet junction box;
8. the connection between the electrical cabinet junction box and the PLC input module.

### Heating channel test

Each heating cable has a dedicated subsystem for safety and power control.

The testing procedure has verified:

1. the connection to the right power line. Lifus 6 uses a mix of 110 and 220 VAC heating cables; the cables are distributed on five power lines (three lines at 220 VAC, two lines at 110 VAC) in order to maintain the main, three phase power line in equilibrium (minimize the net neutral current);
2. the operation of the manual (with protection fuse) switch;
3. the operation of the KHx relais; for the H-1 cable the KH1 relais is controlled by the N.I. PLC using a digital output. An auxiliary contact is used to verify the actual state of the KH1 relais;
4. the operation of the power regulator RJ1P23V30E. The power regulator uses a solid state switch in phase controlled mode. The control signal comes from one current (0-20 mA) analog output of the N.I. PLC and is converted in 0-10V control signal using a 500 Ohms resistor;
5. the connection between the electrical cabinet junction box and the plant junction box;
6. the connection between the plant junction box and the heating cable cold tail.

### *2.8.2 Phase II: argon washing and burn-in up to 250°C.*

In contemporary with the previous tests, a second version (v 0.2) of the control software has been developed, implementing a complete and tested mapping of the physical input/output signals on internal variables. The coding of the most important control loop and the associated safety routine have been completed. Figure 17 is a screenshot of a software window, which graphically shows the entirety of Lifus 6 plant with its main readable and adjustable parameters; other windows can be opened, detailing plant subsections and allowing to customize all the devices' operating conditions and alarm settings.

Using this software version, the plant (Hot Trap excluded) has been washed at ambient temperature with Argon, first removing the air with the E-5 vacuum pump (see Figure 15 for its identification), then filling the plant with Argon up to 1.2 bar (absolute). This washing cycle has been repeated 5 times.



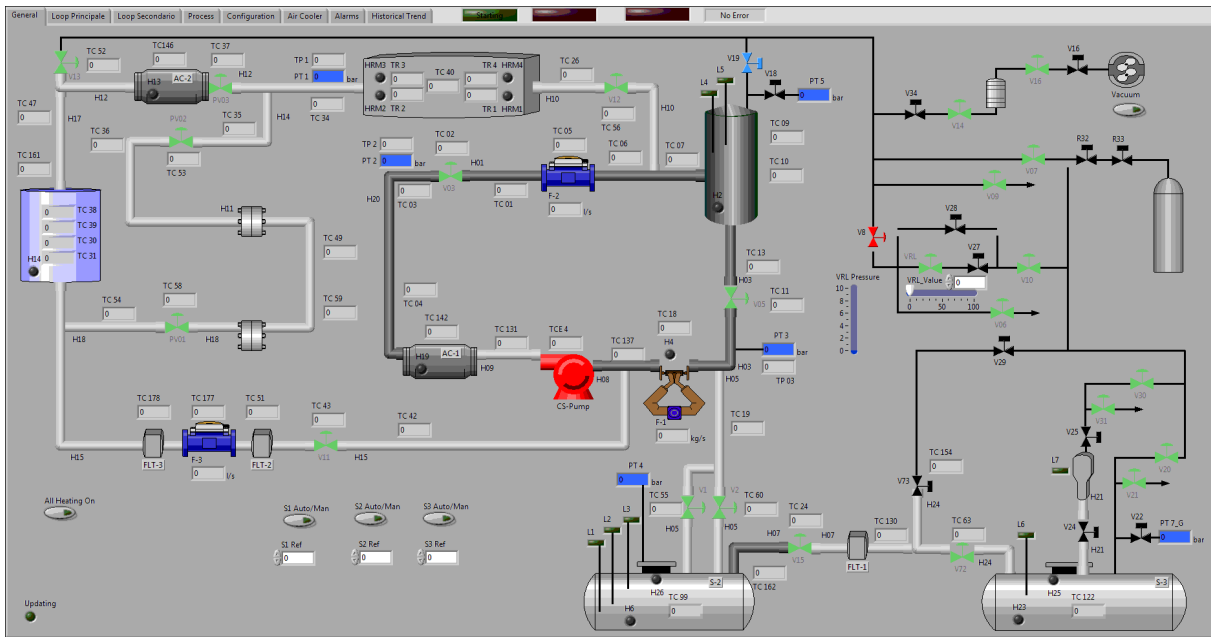

Figure 17: screenshot of a software window (Lifus 6 overall view)

The plant has been then heated up to 250°C, setting a temperature slope in the range + 10÷20° C/h. After each 50°C increase, the washing procedure (evacuation + pressurization) has been repeated. Once reached the maximum temperature (250°C), two separate tests have been performed, each one lasting 5 days, accumulating 10 days of continuous operation.

These tests have allowed to:

1. remove the gaseous impurities/moisture inside the plant pipelines;
2. remove the moisture in the insulating material and verify its performances;
3. check sensor, actuators and control system of many of the heating channels;
4. verify the functioning of the aircoolers AC-1 and AC-2;
5. verify the internal heating of the electromagnetic pump E-1;
6. verify the performance of the Resistivity Meter, particularly the stability of its temperature regulating system and the relation linking Resistance to Temperature, in absence of Lithium (empty capillary).

All the operative parameters have been registered with a sampling frequency of 1Hz and stored in the PC archive.

### 3 Conclusions

Lifus 6 plant, whose design and basic construction had been already realized during previous years by ENEA in its research centre of Brasimone, has finally come to a complete and mature version. Not only all the main hardware elements have been installed, but also all the auxiliary ones and every kind of gauge allowing to real time monitor the proper functioning of each single device. The huge and solid work done in the physical realization of the plant and all its interfaces has been widely supported by an equally considerable and meticulous work in the check of all the input/output signals and in the realization of a dedicated software to interact with the plant and control its operating parameters. After the first test performed in Argon up to 250°C, a new one, entailing to

check the loop at 350°C and the Hot Trap at 650°C, is going to take place in next days. Later, as soon as the Italian Fire Department will formally release the proper safety certification, it will be possible to load Lithium inside the plant and start the real experimental activity, following the already described procedure [2].

## 4 References

1. A. Tincani, A. Aiello, S. Mannori, C. Lenzi, G. Fasano, M. Muzzarelli “Realizzazione e qualifica dell’impianto sperimentale per prove di corrosione/erosione in litio (LIFUS6)”, Report RdS/2013/124, settembre 2013
2. P. Favuzza, “Rapporto sulla validazione del sistema di purificazione del litio all’interno di Lifus 6 e del sistema di monitoring online di tali impurezze”, Report RdS/2013/126, settembre 2013
3. A. Aiello, A. Tincani, P. Favuzza, F.S. Nitti, L. Sansone, G. Miccichè, M. Muzzarelli, G. Fasano, P. Agostini, “Lifus (lithium for fusion) 6 loop design and construction”, Fusion Engineering and Design, 88 (2013), pp 769– 773

## 5 Abbreviations and acronyms

DACS	Data Acquisition and Control System
EM	Electromagnetic
EVEDA	Engineering Validation and Engineering Design Activities
IFMIF	International Fusion Material Irradiation Facility
PA	Procurement Arrangement
PLC	Programmable Logic Controller
P&ID	Piping and Instrumentation Diagram
RAFM	Reduced Activation Ferritic Martensitic
RTD	Resistance Temperature Detector
TC	Thermocouple