



Agenzia Nazionale per le Nuove Tecnologie,
l'Energia e lo Sviluppo Economico Sostenibile



Ministero dello Sviluppo Economico

RICERCA DI SISTEMA ELETTRICO

Specifiche tecniche per la realizzazione degli alimentatori AC/DC
e dei trasformatori del sistema poloidale della macchina tokamak
JT-60SA

Roberto Coletti, Fabio Starace



SPECIFICHE TECNICHE PER LA REALIZZAZIONE DEGLI ALIMENTATORI AC/DC E DEI TRASFORMATORI DEL SISTEMA POLOIDALE DELLA MACCHINA TOKAMAK JT-60SA

Roberto Coletti, Fabio Starace (ENEA)

Novembre 2011

Report Ricerca di Sistema Elettrico

Accordo di Programma Ministero dello Sviluppo Economico – ENEA

Area: Governo, gestione e sviluppo del sistema elettrico nazionale

Progetto: Fusione nucleare: Attività di fisica e tecnologia della fusione complementari ad ITER, denominate "Broader Approach"

Responsabile Progetto: Aldo Pizzuto, ENEA

NOTE

Il Broader Approach è un accordo di cooperazione internazionale tra Unione Europea (Euratom) e Giappone avente lo scopo di integrare il progetto ITER ed accelerare i tempi per la realizzazione dell'energia da fusione, attraverso attività di R&S relative a tecnologie avanzate per i futuri reattori dimostrativi.

L'accordo, al quale l'Italia ha aderito, consiste in una serie di attività sia di fisica che di tecnologia che prevedono realizzazioni prototipiche di alto contenuto tecnologico.

In questo quadro l'ENEA è chiamata a fornire, in opera una serie di impianti di elettronica di potenza AC/DC per l'alimentazione delle bobine superconduttrici dei Central Solenoids (CS - 4 sistemi), degli Equilibrium Field (EF - 2 sistemi) e degli alimentatori per il Controllo Veloce della Posizione del Plasma (FPPC - 2 sistemi).

Il sito di installazione è il centro di ricerca di Naka – Ibaraki circa 150 km a nord di Tokyo in Giappone.

Questi sistemi non verranno installati in "green field" ma dovranno essere inseriti in sistemi e impianti esistenti e, in parte ad essi collegati. Per questo si sono avuti slittamenti dei tempi dovuti agli smontaggi, revisioni delle zone di allocazione dovute alle facility necessarie e in ultimo alle verifiche strutturali post sisma.

La specifica è stata redatta in lingua inglese perchè soggetta a discussione e accettazione da parte di F4E (Fusion For Energy) e JAEA (Japan Atomic Energy Agency).

ENEA ID	SPT-TFJT60SCMPS-01		ENEA Classification	D
<p>Title:</p> <h2 style="margin: 0;">Procurement Technical Specifications</h2> <p style="margin: 0;">for the Agreement Of Collaboration F4E-ENEA for the Joint Implementation of the Procurement Arrangement for the Poloidal Fields and Fast Plasma Position Control Coils Power Supplies for the Satellite Tokamak Programme</p>				
Contract or Project Details				
	<p><i>This document is issued for the execution of the Agreement of Collaboration (AoC) between Fusion for Energy (F4E) and ENEA for the joint implementation of the Procurement Arrangement (PA) for the Poloidal Fields (PF) and Fast Plasma Position Control Coils (FPPC) Power Supplies for the Satellite Tokamak Programme.</i></p>			
	JT-60SA DMS	BA_D_-----		
Author(s) & Contributor(s)	Starace Fabio		Coletti Roberto	
	UT-FUSING Via E. Fermi, 45 00044 – Frascati (RM), Italy Tel. +39 06 94005276 Fax +39 06 94005734 E-mail: fabio.starace@enea.it		UT-FUSIMP Via E. Fermi, 45 00044 – Frascati (RM), Italy Tel. +39 06 94005212 Fax +39 06 94005524 E-mail: roberto.coletti@enea.it	
Distribution List (Registered)	Internal ENEA	L. Di Pace, C. Nardi, A. Lampasi, P. Costa		
		F4E, JAEA		
Abstract	<p>This document briefly describes the procedure identified by ENEA for the Agreement of Collaboration (AoC) Plan of the JT-60SA Poloidal Fields (CS1-CS4, EF1 and EF6) and Fast Plasma Position Control Coils (FPPC1 and FPPC2) power supply systems.</p>			

1	04 July 2011	Fabio Starace Roberto Coletti	Luigi Di Pace	Roberto Coletti
Rev.	Date	Issued by	Reviewed by	Approved by

TABLE OF CONTENT

LIST OF TABLES	6
LIST OF FIGURES	7
1. SCOPE OF THE PROCUREMENT ARRANGEMENT	8
1.1. Scope of the Supply	8
1.2. Main deliverables	8
1.3. Items not included in the supply	9
1.4. Warranty	9
1.5. Spares	9
2. DELIVERY SCHEDULE	10
Delivery schedule is reported in Table 2-1.	10
3. REFERENCE AND APPLICABLE DOCUMENTS	10
4. TECHNICAL REQUIREMENTS	10
4.1. Existing AC Power Supply System	10
4.2. General requirements	14
4.2.1. Design and construction	14
4.2.2. Redundancy and safety factors	14
4.2.3. Transmission and insulation of signals	14
4.2.4. Combustible materials	14
4.2.5. Cleaning and painting	15
4.2.6. Audible noise	15
4.2.7. Use of oil	15
4.2.8. Use of ISO metric threads	15
4.2.9. Anti-condensation heaters	15
4.2.10. Fire and explosion protection	15
4.2.11. Access to equipments	15
4.2.12. Grounding	15
4.2.13. Reactors	16
4.2.14. Capacitors	16
4.2.15. Cables and fibres optics	16
4.2.16. Demineralised water cooling system	16
4.2.17. Cubicles IP codes	17
4.2.18. Local control cubicles	18
4.2.19. LV AC Connections	19
4.2.20. Crowbar units	19
4.2.21. Disconnectors	21
4.2.22. Compressed air	21
4.2.23. Measurement transducers	21
4.2.24. Special Tools and needed equipments for operation and maintenance	21
4.3. TF coil power supply (OUT OF SCOPE – Provided by CEA - France)	21
4.4. PF coil power supplies (PFC PS)	22
4.4.1. Reference schemes	22
4.4.2. Performances	24
4.4.3. Operational requirement for PFC PS units	25
4.4.4. Thyristors cubicle design	31
4.4.5. Transformers	31
4.5. FPPC coils power supplies	32
4.5.1. Performance and operational requirement	32
4.5.2. Transformers	33
4.6. PS interfaces requirements	34
4.6.1. Interfaces with other units of the dc power circuit	35
4.6.2. Interfaces with APS low voltage distribution system	36
4.6.3. Interfaces with the compressed air distribution system	36

4.6.4.	Interfaces with the site water cooling system _____	36
4.6.5.	Interfaces with the grounding network _____	37
4.6.6.	Interfaces with the SCSDAS, GPS and SIS _____	37
4.7.	<i>Thyristors converter regulation / Control and protection system</i> _____	37
4.7.1.	Thyristor convertor regulator _____	37
4.7.2.	Control and protection system _____	38
4.8.	<i>Layout , assembly, installation and commissioning requirements</i> _____	39
5.	TESTING AND APPROVAL REQUIREMENTS _____	40
5.1.	<i>General requirements</i> _____	40
5.2.	<i>Factory Test of Power Supplies Units</i> _____	40
5.2.1.	PS (Thyristors Cubicle including interphase reactances and and Crow bar switch) _____	40
5.2.2.	Control and regulation cubicle _____	41
5.2.3.	Transformers _____	41
5.3.	<i>Final Acceptance Tests on Site</i> _____	41
6.	CODES AND STANDARDS _____	42
7.	PACKAGING AND TRANSPORTATION REQUIREMENTS _____	42
8.	DOCUMENTATION TO BE SUPPLIED _____	42
8.1.	<i>Design Reports</i> _____	42
8.1.1.	First Design Report _____	43
8.1.2.	Transformers Design Report _____	43
8.1.3.	Final Design Report _____	43
8.2.	<i>Detailed Testing Plan</i> _____	43
8.3.	<i>Tests reports</i> _____	43
8.4.	<i>Operation and Maintenance Manual</i> _____	44
8.5.	<i>Source codes</i> _____	44
8.6.	<i>Final Report</i> _____	44
9.	TRAINING _____	44
10.	NAKA SITE CONDITIONS _____	44
10.1.	<i>Ambient conditions</i> _____	44
10.2.	<i>Seismic event</i> _____	45
10.3.	<i>The low voltage distribution system</i> _____	45
10.4.	<i>Grounding network</i> _____	45
10.5.	<i>Facilities in the PS buildings</i> _____	46
10.5.1.	Site water cooling systems _____	46
10.5.2.	Air conditioning system _____	46
10.5.3.	Compressed air system _____	46
11.	QUALITY ASSURANCE DOCUMENTS _____	46

List of Tables

Table	Title	Page
1.1-1	Scope of the Supply	6
1.2-1	Main components to be delivered	6
1.3-1	Items not included in the supply	7
2-1	Delivery Schedule	8
3-1	Reference and Applicable Document	8
4.2.19-1	Correspondence between existing Transformers and new Converters	17
4.2.20-1	Reference Design Parameters for Crow Bar Units	18
4.4.2-1	Reference Design Parameters for PFC power supplies	22
4.4.3-1	Reference waveforms to be used for the thermal design of the converters	23
4.4.5-1	Reference design Parameters for CS2/CS3 PS transformers	29
4.5.1-1	Reference Design Parameters for FPPCC PSs	31
4.5.2-1	Reference Design Parameters for FPPCC PSs Transformers	32
4.6.2-1	Available power for APS	34
4.6.4-1	Main characteristics of demineralised water for Aluminium Components	34
5.3-1	Withstand Voltage to Ground (kVac, 50Hz, 10min) for Final Acceptance Tests on Site	39
10.3-1	Parameter of the JT-60SA low voltage distribution system at the connection point with the PS	44
10.5.3-1	Parameters of the JT-60SA compressed air distribution system	45

List of Figures

Figure	Title	Page
4.1.1-1	General overview of AC power system Network Distribution	9
4.1.1-2	11kV, 50Hz Network Distribution	9
4.1.1-3	Network distribution for H-MG	10
4.1.1-4	18kV, 77.6-54.2 Hz H-MG network distribution	11
4.2.20-1	Simplified Crow Bar reference scheme	18
4.2.20-2	Simplified Crowbar operation sequence	18
4.4.1-1	JT-60SA reference schemes	20
4.4.3.1-1	CS1 - CS4 Converter Operation Modes with respect to Load Current	25
4.4.3.1-2	CS1-CS4 Current path inside the converter during different operation mode	26
4.4.3.1-3	CS1-CS4 Synthesis of the converter operation modes	26
4.4.3.2-1	EF1,EF6 Converter Operation Modes with respect to Load Current	27
4.4.3.2-2	EF1,EF6 Current path inside the converter during different operation mode	28
4.4.3.2-3	EF1,EF6 Synthesis of the converter operation modes	28
4.5-1	Reference scheme for FPPC coil PS	30
4.5.1-1	Estimated induced current inside upper/lower FPPC coils	31
4.6-1	Overall view of interfaces between PS and the other JT-60SA systems	33

1. SCOPE OF THE PROCUREMENT ARRANGEMENT

1.1. *Scope of the Supply*

JT-60SA Super Conducting Magnet (SCM) Power Supply (PS) includes the following components :

1 Toroidal Field Coil Power Supply (TFC PS), (out of this procurement)

2 Central Solenoids (PCS PS)

3 Equilibrium Field) Power Supply (PFC PS) (only PEF1 and PEF6)

4 Fast Plasma Position Control Coils Power Supply, upper and lower (FPPC PS).

The general scope of the supply of the STP Superconducting Magnets Power Supplies (SCMPS) Procurement Arrangement (ref. JT-60SA WBS/PBS 7.0, 7.1, 7.4, 7.5) is specified in Table 1.1-1.

Table 1.1-1 : Scope of the Supply

Detailed Design
Manufacturing
Factory tests
Packaging
Documentation
Transportation from Manufacturer premises to Port of Entry according to art.5 of Procurement Arrangement
Handling from storage areas to the final location, assembly, installation and commissioning
Final Acceptance Tests on Site
Basic set of spares parts
Training of operating staff

1.2. *Main deliverables*

Main components to be delivered by F4E are reported in Table 1.2-1

Table 1.2-1 : Main components to be delivered

SCMPS	Cubicle / fences (*)	Control / protection system	Interphase inductances	Crowbar	Transformers	AC/DC Disconnectors (****)	Maintenance tools (***)	Ref. Section
CS1 PS	✓	✓	✓	✓			✓	4.4
CS2 PS	✓	✓	✓	✓	✓		✓	4.4
CS3 PS	✓	✓	✓	✓	✓		✓	4.4
CS4 PS	✓	✓	✓	✓			✓	4.4
EF1 PS	✓	✓	✓	✓			✓	4.4
EF6 PS	✓	✓	✓	✓			✓	4.4
FPPC up. PS	✓	✓	✓	✓	✓(**)		✓	4.5
FPPC low. PS	✓	✓	✓	✓	✓(**)		✓	4.5

(*) ref. Section 4.2.17

(**) This PS is fed by two transformers to allow a 12 pulses operation also during the circulating current phase

(***) Including :

- any set of special handling tools and appliances that may be necessary to handle the equipment safely and conveniently during its receipt and assembly at Site (these will remain property of JT-60SA);

- any special tool and special equipment necessary for the operation and maintenance of the equipments included in the Supply (these will remain the property of the JT-60SA);
- any set of testing tools and instruments need to commission and test the system will be procured by the Manufacturer designated by F4E (hereinafter referred as to “Manufacturer”) and it will remain his own property.

(****) These disconnectors are in addition to existing components. AC disconnectors are only related to transformer secondary side input and they are to be still confirmed during the Detailed Design Phase (DDP).

1.3. Items not included in the supply

Items not included in the supply are reported in Table 1.3-1

Table 1.3-1 : Items not included in the supply

All DC busbars and related connections to each SCMPS
AC HV cables installation/modifications on SCMPS transformers primary side
AC HV circuit breaker including protection relays
AC LV cables on transformers secondary/tertiary side(s) for CS1, CS4, EF1, EF6 PSs
Transformers for CS1, CS4, EF1, , EF6 PSs
Ground grid and ground connection to each SCMPS
AC/DC low voltage auxiliaries power supply and related connections to each SCMPS
Compressed air distribution system and related connection to each SCMPS
Demineralised water cooling system and related connection to each SCMPS
JT-60SA Supervisor Control System Data Acquisition System (SCSDAS) including the Global Protection System (GPS) and related connections to each SCMPS
JT-60SA Safety Interlock System (SIS) and related connections to each SCMPS
All PFC, FPPC Coils measurements and monitoring systems
All infrastructures needed to house each SCMPS, including any major civil work needed for a proper installation of the SCMPSs
Fire prevention, detection and intervention system
Any provision for the protection of the SCMPSs from lightning
Decommissioning
Transportation from Port of Entry in Japan to Naka Site
Utilities during installation, commissioning and testing

1.4. Warranty

All components shall have a warranty for defects in the manufacture for a period of two years from the acceptance of the components.

The warranty is limited to the direct costs of repair or remanufacturing of the components. Any other warranty is excluded.

1.5. Spares

F4E shall provide within this procurement a basic set of spare parts at least composed of:

- One thyristor arm for each type of thyristor converter (including gate firing)
- One semi-conductor stack for each type of Crowbar units (including Break Over Diode – BOD – and gate firing)
- A set of sacrificial contact for each type of Crowbar units mechanical bypass

During the Detailed Design Phase, the Manufacturer shall provide the list of recommended spares that could be ordered by JAEA to cover the specified operational life of the equipment, beyond the warranty period. The list shall include the individual prices and the indication of period of validity.

The preparation of the lists described above will not relieve the Manufacturer from their obligation to cover replacement of any parts damaged during installation and site testing.

Fusion for Energy can request an extension of the standard commercial warranty or supply of spare parts on the basis of the list provided by the Manufacturer. This option can be exercised, at the price proposed in the list, till the delivery of the Supply; the spare list can be altered in order to purchase fewer or more parts with no cost variation.

2. DELIVERY SCHEDULE

Delivery schedule is reported in Table 2-1.

Table 2-1 : Delivery Schedule

Item	Delivery Schedule
JT-60SA SCM PS	July 31 st , 2016

3. REFERENCE AND APPLICABLE DOCUMENTS

Reference and applicable documents are reported in Table 3-1.

Table 3-1 : Reference and Applicable Document

Reference Number	Document Title	IDM reference
1	JT-60SA Plant Integration Document (PID)	AST_D_222_QVA
2	JT-60SA Integrated Project Team Common Quality Management System	AST_D_223AVV
3	JT-60SA EU Home Team Quality Management System	AST_D_223C97

4. TECHNICAL REQUIREMENTS

4.1. Existing AC Power Supply System

Figures from 4.1.1-1 to 4.1.1-4 show the diagrams of JT-60SA AC power supply system at Naka fusion Institute. Basically, the AC power supply system will be reused as far as possible. New power supply systems will be designed and manufactured to feed superconducting TF, and PF coils. TFC PS will be fed by the existing 11kV, 50Hz network, while PFC and FPPCC PSs will be fed by the existing H-MG through the 18kV network generated.

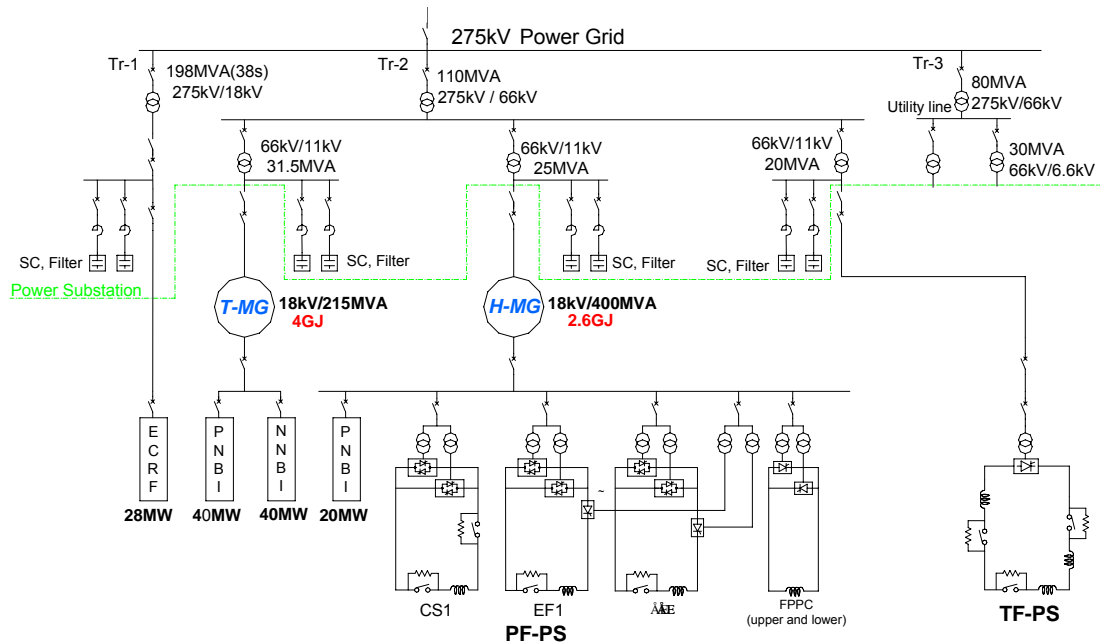

Fig 4.1.1 – 1 General overview of AC power system Network Distribution

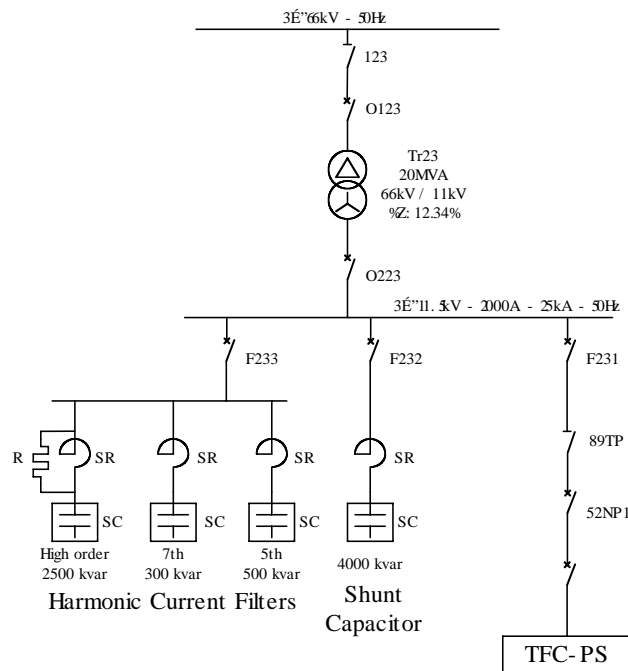

Fig 4.1.1-2 11kV, 50Hz Network Distribution

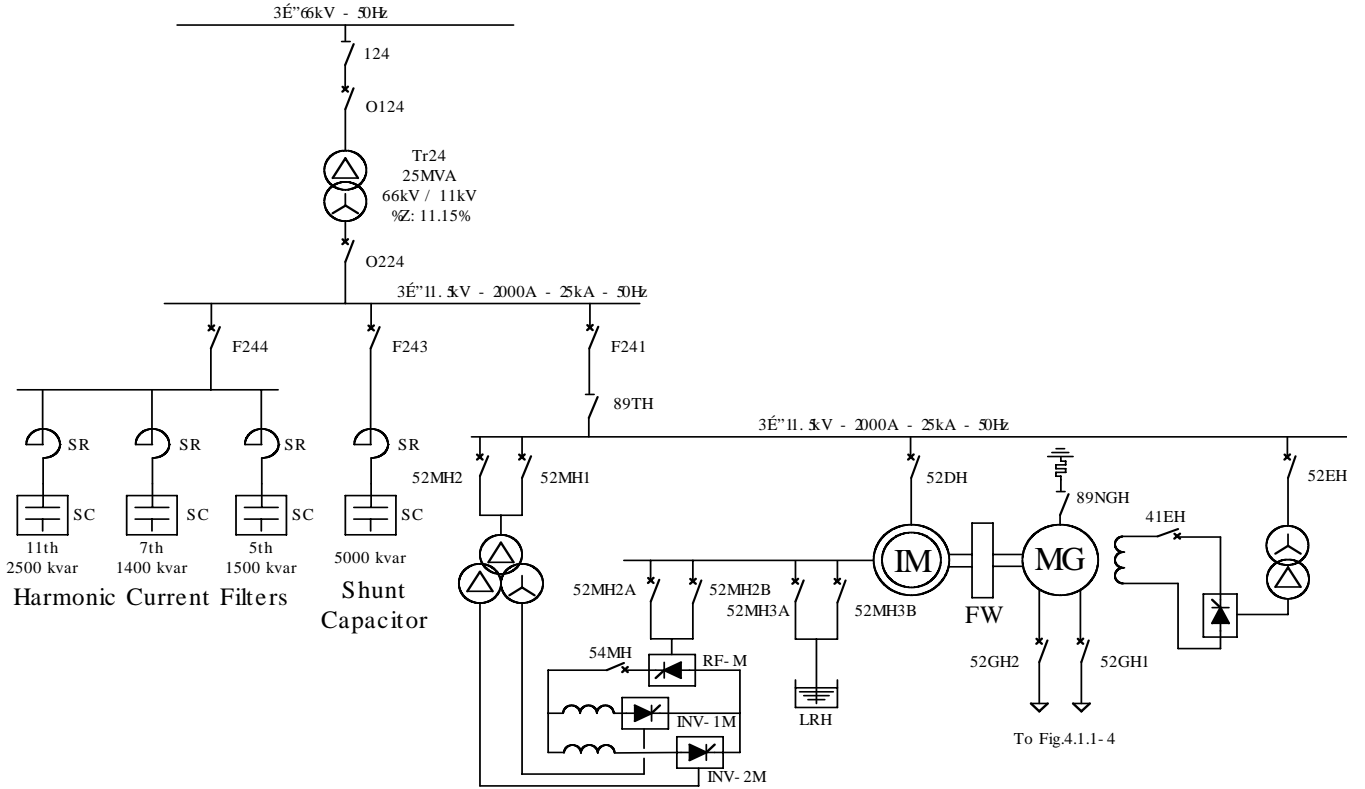

Fig 4.1.1-3 Network distribution for H-MG

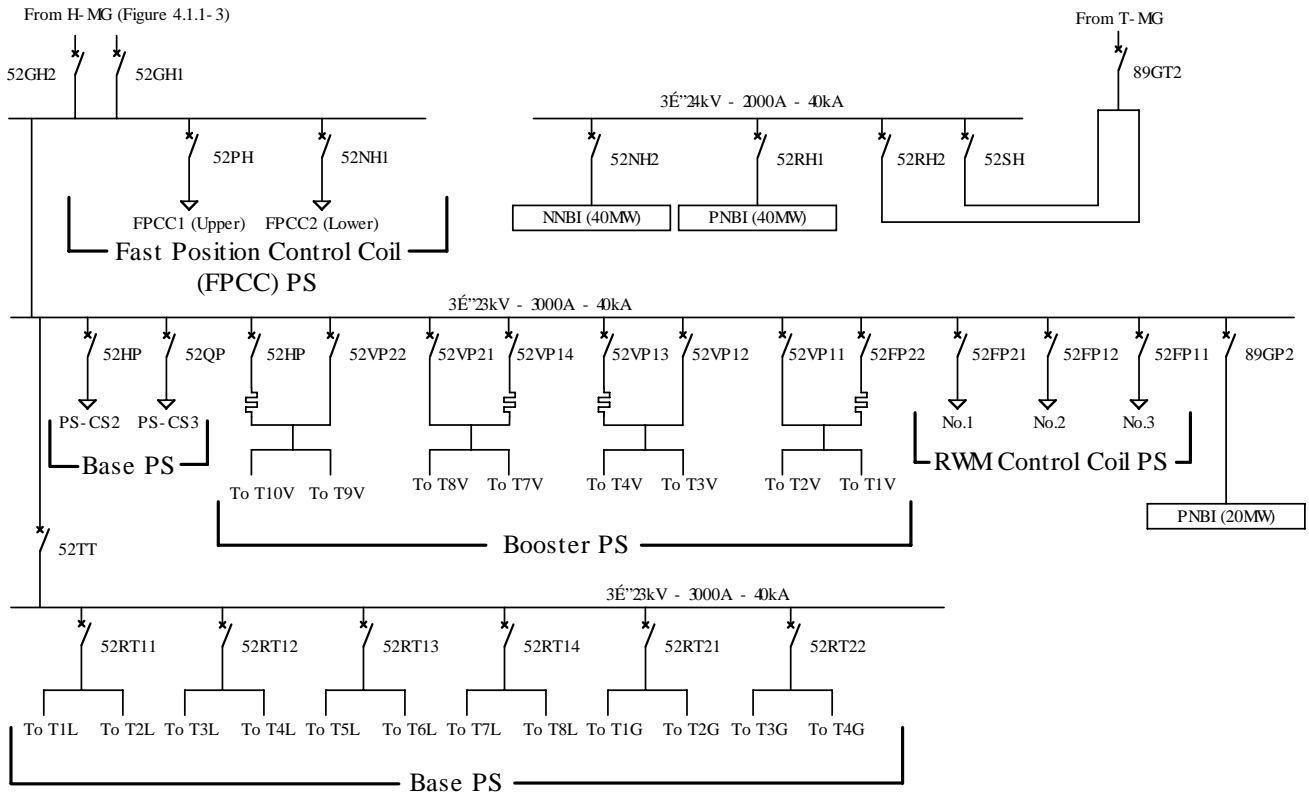

Fig 4.1.1-4 18kV, 77.6-54.2 Hz H-MG network distribution

4.2. General requirements

This Section provides requirements which shall be fulfilled unless otherwise agreed by F4E and JAEA (hereinafter referred to as "agreed") during the Detailed Design Phase (DDP).

4.2.1. Design and construction

The design and construction of the equipment shall conform to the best current engineering practice and in agreement with IEC Std. The essence of design shall be simplicity and reliability in order to give long continuous service with minimum maintenance requirements.

Modularity shall be used to the maximum extent possible so as to minimize the time required for maintenance and repair.

All components and cables shall be able to support mechanical forces during shipment, and electromagnetic forces occurring during normal operation and fault conditions.

4.2.2. Redundancy and safety factors

Thyristor converters shall be designed in agreement with IEC 60146 Standard.

In order to ensure a good reliability for the PS systems, a suitable high safety factors shall be adopted at least not less than the maximum normally followed in industrial practice. In particular, the following values shall be taken into accounts for thyristors/diodes:

- Voltage safety factor (defined as max repetitive peak forward blocking voltage/secondary transformer no-load RMS voltage) : $\geq 3,5$
- Junction temperature:
 - o **In normal operation:** the maximum junction temperature shall be at least less than the maximum junction temperature recommended in thyristor data sheet
- Current sharing factor in case of paralleled components : $\geq 1,2$

In case of redundant components, the failure of one component shall result in the exclusion/by-passing of that component without affecting the operation of the overall device. An alarm shall be generated to warn about the failure.

4.2.3. Transmission and insulation of signals

The transmission of the signals between components placed inside high voltage areas and components/equipment placed in low voltage (accessible) areas shall be as much as possible via optic fibres, which also assure the insulation of the signals.

If the signal transmission via cable is selected, the signals shall be double isolated for the relevant test voltage applicable to the particular HV component, in such a way that failure of one insulating layer does not endanger personnel and/or equipment at the low voltage side.

Alternatively a screen may be provided between high voltage circuits and low voltage parts. The screen will in general be connected to the local ground system of the supply. The screen shall be able to withstand the relevant fault current for the time required to clear the fault.

Different arrangements shall be agreed during the DDP.

4.2.4. Combustible materials

Material that would support combustion must be LSOHFR (Low Smoke Zero Halogen Fire Retardant). In particular for cables and optical fibres refer to Section 4.2.15.

4.2.5. Cleaning and painting

Before receiving any protective coating or paint, all parts of the equipment shall be cleaned to remove all corrosion and foreign materials. All interior and exterior surfaces shall receive a suitable inhibitive primer treatment and two coats of finish paint. The board colours will be agreed during the DDP .

4.2.6. Audible noise

This section refers to the audible noise outside the cubicles in normal operating conditions (i.e closed doors). In stationary conditions, all equipment shall operate without undue vibration and with least possible amount of audible noise to avoid causing any harmful effect. In particular the daily average noise value (calculated as an average over 8 hours and expressed in dB(A)) must not exceed 85 dB(A) when measured at 2 meters and using an instrument according to IEC 61672. During the switching phase, peak noise and vibrations shall be reduced under a threshold to be defined during DDP.

4.2.7. Use of oil

PCB (polychlorinated biphenyl) and PCT (polychlorinated triphenyl) type materials shall not be used in any component. Oil filled equipment shall not be installed indoor .

4.2.8. Use of ISO metric threads

All nuts, bolts, studs, washers etc. shall be of standard ISO metric sizes. Other sizes might be agreed during DDP .

4.2.9. Anti-condensation heaters

All items of electrical equipment which are liable to suffer from internal condensation shall be fitted with thermostatically controlled heating elements of sufficient power to raise the temperature to a level which will prevent condensation in worst ambient conditions (ref Section .10)

The operation of the heaters shall be monitored and an alarm raised in case of failure. Local visible indication of failure shall also be provided.

These space heaters shall be energised separately from any other equipment in the enclosure/cabinet.

4.2.10. Fire and explosion protection

Smoke detector and other fire protection devices are not requested inside any procured electrical cubicle.

All cubicles have to be designed to confine any possible explosion of any component inside.

4.2.11. Access to equipments

Provision, including a suitable internal illumination system, shall be made for easy access to all equipment and components for maintenance and troubleshooting.

If the boards will be provided by windows, the glass used, shall be of shatterproof safety type.

4.2.12. Grounding

All equipment enclosures and screens shall be grounded wherever applicable.

Each enclosure shall be provided with suitable bonding leads to connect together all the part of the enclosures (e.g. doors) and all items inside the enclosure requiring grounding.

All the ground conductors shall be made of copper and shall be sized to carry the fault current without voltage rises dangerous for the human safety. All power ground leads for HV equipment shall be sized in according to the IEC standards applicable to the components/sub-systems of the supply. All the grounding connections shall be clearly pointed out and easily accessible.

4.2.13. Reactors

To comply with the technical PS requirements (Sections 4.4 and 4.5), interphase reactors between two parallel bridge or/and back to back connections are needed.

The scope of these reactors is:

- Parallel connection: due to the instantaneous outputs of each rectifier are not equal, an interphase reactor is used to support the difference in instantaneous rectifier output voltages and allow each rectifier to operate independently.
- Back to back connection: an interphase reactor is necessary to suppress the circulating current within 10% (maximum nominal current) of the rated converter current, and to reduce the circulating current ripple that, for the transformers with the phase shifting of 30 degrees, might be large

For all these reasons it seems to be better to use a saturable reactor type to provide the two necessary inductance values in both full and circulating current condition. In any case the Manufacturer could evaluate different solutions that shall be quoted in the offer separately. The Manufacturer shall prove the convenience of alternative solutions which shall be agreed during the DDP of the Contract.

Attention must to be taken that the reactors are situated sufficiently far away from neighbouring metallic parts to ensure that these aren't heated excessively by eddy currents.

For filter reactors the inductance (as well as the values of the resistance and stray capacitance) shall be kept within the design limits required for the correct operation and the desired performance of the filter. The determination of the inductance value shall take into account the expected conditions of installation and the presence of nearby metallic structures. Details shall be agreed during the DDP of the Contract.

4.2.14. Capacitors

Power capacitors may be used in various parts of the supply: filters, snubber circuits, capacitor banks...

The nominal values of capacitance for each capacitor unit shall be referred at a frequency or typical frequencies range of the specific applications.

The tolerance of the capacitance with respect to the nominal value shall be according to the relevant IEC standard.

4.2.15. Cables and fibres optics

All used cables shall be selected, sized and laid according to applicable IEC standards, in particular IEC60502.

All power, measurement, control and auxiliary cables shall be made of copper.

Cable and fibre optics insulation shall be LSOHFR (Low Smoke Zero Halogen Fire Retardant, ref IEC60332-1, -2 and -3).

Cables/busbars shall be de-rated for parallel connection and installation as for the latest issue of the applicable IEC standards.

All cables and fibre-optic cables shall have appropriate mechanical support to minimise constrains on the connectors and respect manufacture requirements on bending radius.

Cables carrying signals from different sources shall be segregated into groups, and marked appropriately with the identity of the source.

Analogue signals shall be routed separately from digital signals, using different cables. To reduce interference on control, protection and monitoring signals, twisted pair cables shall be used and located inside proper cable trays. During the DDP, the Manufacturer shall demonstrate that the proposed cabling and wiring systems are comply with EMI/EMC IEC standards.

Each multi-pair or multicore cable shall allow for at least 20% spare capacity. All spare cores shall be terminated.

The design of the fibre optic transmission system shall allow for at least 10% spare fibre optic cable capacity.

Within cubicles/panels, all cables shall be clearly identified with a label of an approved type and this label shall be clearly visible from within the cubicle/panel.

4.2.16. Demineralised water cooling system

Demineralised water cooling system will be made available by JAEA near by each PS unit. This section gives the technical requirements of the demineralised water cooling system for all TFC, PFC, and FPPCC PSs. In the following both the possibilities are considered of an internal closed loop water cooling circuit, provided by the

Manufacturer and connected through an heat exchanger to the JAEA water cooling system (external closed loop cooling), and of directly cooling from the JAEA demineralised water cooling system (JAEA cooling).

4.4.3.4 *Control and monitoring*

The demineralised water cooling system shall be provided with a local control panel for local control, monitoring, alarm and signal conditioning, protection and interlock. The local control panel shall house the motor starters, control relays, interface units for transducers, marshalling terminal blocks, indication and local command switches. At least the following measurements shall be made available at the water cooling system control panel:

- 1) Inlet water flow;
- 2) Inlet water temperature
- 3) Inlet water pressure
- 4) Inlet water conductivity
- 5) Outcome water temperature
- 6) Outcome water pressure
- 7) internal water flow (in case of an internal closed loop water cooling system is used);
- 8) internal water conductivity (in case of an internal closed loop water cooling system is used);
- 9) internal water temperature (in case of an internal closed loop water cooling system is used);
- 10) internal water level monitor sensors (in case of an internal closed loop water cooling system is used).

At least the following alarm signals shall be made available at the water cooling system control panel:

- 1) low flow
- 2) water low resistivity
- 3) water high temperature
- 4) low flow for the internal closed loop circuit (if any);
- 5) internal water low resistivity (if it is the case);
- 6) internal water high temperature (if it is the case);
- 7) abnormal internal water level (if it is the case);
- 8) pump motor overload;
- 9) undervoltage in the auxiliary circuit;
- 10) earth leakage current.

The alarm thresholds shall be easily adjustable via the water cooling system control panel. A general alarm, collecting all the alarms of the PS water cooling system, shall be sent to the PS LCC (Local Control cubicle) .

4.2.17. Cubicles IP codes

As a general rule, all components will be housed inside proper closed cubicles. In some specific cases or as an alternative to be offered separately, the Manufacturer could propose installation inside fences. This has to be agreed during the DDP. In any case the Manufacturer shall take the full responsibility to provide and install the fences including all human safety provisions required by the local rules.

4.4.3.5 *Power cubicles*

The IP code for the indoor enclosures of the electrical equipments are indicatively assumed to be IP 5(dust protected) 2(dripping, 15° tilted) D (protected against access with a wire) H(high voltage apparatus).

In the case of the doors of the board are open, it has to be avoid any possible risk for accidental direct and indirect contacts to electrical active parts by the operator (for example Plexiglas screens will be installed inside the cubicle). At least the minimum level protection shall be IP3. According to feasibility, a safety dedicated key-board system will be also installed to be sure that both related AC and DC powers are shutdown before opening any cubicle.

4.4.3.6 *Control cubicles*

The IP code for the indoor enclosures of the electrical equipments are indicatively assumed to be IP 5(dust protected) 2(dripping, 15° tilted) D (protected against access with a wire) H(high voltage apparatus). In the case of the doors of the board are open, the IP3 is requested to avoid any possible risk for accidental direct and indirect contacts to electrical active parts by the operator.

4.2.18. *Local control cubicles*

This Section gives the electrical and mechanical requirements of the PS LCCs.

4.4.3.7 *General*

All LCC hardware shall be housed in cubicles; the degree of protection for the cubicles will comply with Section 4.2.17.2.

Three separated Vdc networks shall be provided by the Manufacturer inside LCC starting from those once made available by JAEA (ref. Section 10.3):

- 1) the first dedicated to power transducers, solenoid valves, emergency-stop buttons and any other equipment not related to I/O;
- 2) the second to supply I/O interfaces, PLCs, communication cards, ...
- 3) the third one to supply the thyristor converter regulator including protections

The Manufacturer will use the proper level of voltage depending on his experience and he will motivate it in the design report.

Above mentioned circuit will be protected by different proper circuit breakers. Additional circuit breakers must be implemented to separate and effectively protect different subsets of equipment according to their location or functionality. Each DC circuit breaker shall cut off both polarities (+Vdc / 0v).

Parts of the system fed by 200/400 Vac will be protected by separated circuit breakers to separate and effectively protect different subsets of components according to their location or functionality. Each circuit breaker shall, in accordance with the IEC standard, be multi-pole; i.e. shall cut off all the phases and the neutral. A set of bus-bars may also be associated, if needed, with the circuit breakers.

A 200 Vac mains plug shall be fitted inside each cabinet and shall be protected by a 16A K curve/ 30 mA HPI differential circuit breaker.

Adequate internal illumination system shall be provided in order to make possible cubicle inspection.

A holder for documents shall be fitted outside one of the cabinet doors.

4.4.3.8 *Equipments inside the cubicles*

Dimensions of any panel, box and cabinet shall make allowance for a minimum of 20% of spare area (for panels) or volume (for boxes and cabinets). The wiring channels shall be halogen-free and flame retardant, fitted with a cover and secured by screws (ref Section 4.2-4).

There shall be at least 150 mm of distance between the terminal blocks and the lower or upper neighbour objects to facilitate cable connection.

The cubicles shall be fitted with low-consumption lamp for internal lighting, switched on by the opening of the doors.

Adequate test points, with easy access, shall be included in the equipment to enable maintenance and troubleshooting to be carried out as quickly as possible. On the basis of a proposal from the Manufacturer, test points will be defined during the DDP.

Taking into account Site Conditions (ref. Section 10) each cubicle must be properly cooled/heated to ensure that all internal components can properly operate and that no damage occur to them .
Visual indications such as LEDs, to indicate the local control status and operating mode, shall be mounted on the front panel.

4.4.3.9 Cabling Terminal blocks / Connectors

Terminal blocks/connectors for cabling shall be selected by the Manufacturer by his on experience and convenience among largely diffused components complying with relevant IEC standards.
No more than two wires shall be connected to each terminal.
Channels of the same type (analogue input, analogue output, digital input and digital output) shall be connected to consecutive groups of terminal blocks and not inter-mixed.
Depending on his selection of cabling connectors, the Manufacturer could be requested to provide also the complementary component for external connections.

4.2.19. LV AC Connections

This section regards LV AC transformers connections.
All connections on the primary side of any transformer, including related withdrawable circuit breakers, will be provided by JAEA and it is out of the scope of the present procurement.
Regarding connections between each bridge of each thyristor converter and the secondary winding of the related transformers:

- in the case transformers already exists, each bridge of single converter is linked with different secondary winding of different Transformers, the Manufacturer shall provide connecting points according to IEC standard and all needed modifications of the existing AC feeders; Tab 4.2.19 -1 shows actual transformers characteristics and connections type for LV AC side
- in the case new transformers are required, the Manufacturer shall provide and install all needed cables/busbars, with the related trays/ducts, and connect them both to transformer and converter side.

Table 4.2.19-1 Correspondence between existing Transformers and new Converters

Transformer Yard (outside)		Rectifier room (Second floor)		cables x phase N.	cable Length m
From		To			
Transformer		Rectifier			
LV side	Phase Shift	JT60	JT60SA		
T1G	-30°	SRG1D	EF6(-30°)	4	38
T1G	0°	SRG1B	EF6(0°)	4	44
T3G	0°	SRG2B	CS1(0°)	4	36
T3G	-30°	SRG2D	CS1(-30°)	4	37
T4G	+15°	SRG2A	CS4(+15°)	4	24
T4G	-15°	SRG2C	CS4(-15°)	4	32
T2G	-15°	SRG1C	EF1(-15°)	4	37
T2G	+15°	SRG1A	EF1(+15°)	4	45

The Manufacturer shall provide the connections (low inductive type) between the existing cable boxes and PS converter boards.

4.2.20. Crowbar units

The scope of the procurement includes Crowbar units (CB) and their busbar connections to the PS.
CBs can be operated in the following cases:

1. automatically, by an internal Break-over-diode (BOD) in case of overvoltages across DC busbars and to ground, the non-linear resistance R_{nl} will protect the PS of the overvoltages before the static switch (BOD) intervention

2. by the thyristor converter control system to protect the converter itself (for example in case of AC voltage missing, internal fault, max DC current....);
3. of an external command by the JT-60SA SCSDAS or GPS (for example in case of Quench Protection Circuit operation).

The proposed reference basic scheme and operation sequence is described in Fig. 4.2.20-1.

In principle no resistance is foreseen in series with the CB. This is to make easier current commutation from the converter into CB and it is considered achievable due the limit current operation of the converter (ref. Section 4.4.4). The Manufacturer shall check the situation during the DDP and propose motivated modifications on the basis of his experience and his calculations. Without any resistance in series with the CB, the time constant of the load current decay will result too high and the consequent I^2t will overcome the CB capability. As a consequence, in case of operation also Quench Protection Circuit must be operated.

The proposed reference scheme and operation sequence is described in Fig. 4.2.20-2. In particular non linear resistances (R_{nl}) are included in order to smooth over voltages across the converter before crowbar operation. The Manufacturer shall verify if these resistors are strictly needed depending on the thyristor converter design. A final decision will be taken during the DDP.

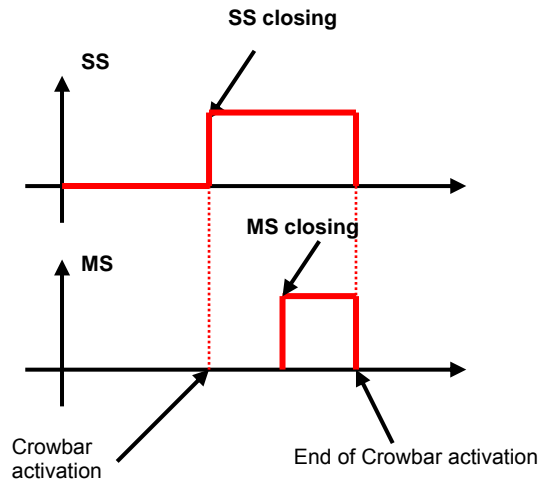
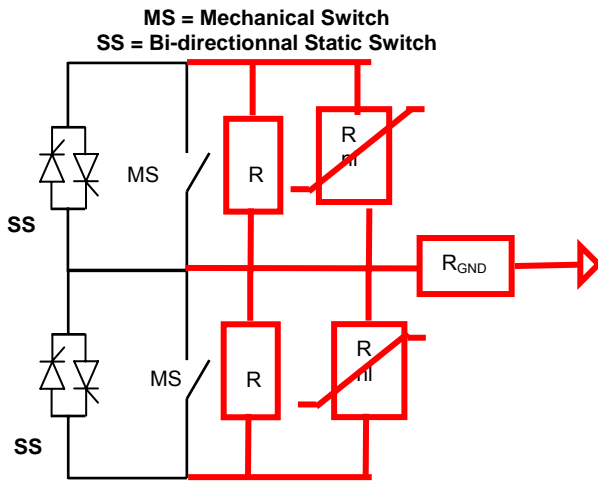

Fig. 4.2.20-1 Simplified Crow Bar reference scheme

Fig. 4.2.20-2 Simplified Crowbar operation sequence

Taking into account the CBs operation has described above, Table 4.2.20-1 shows the reference parameter for CBs design .

Tab 4.2.20-1 Reference Design Parameters for Crow Bar Units

CB Identification	EF1, EF2, EF5, EF6 PS	CS1-4, EF3, EF4 PS	TFC PS	FPPCC PSs
Bidirectional / Unidirectional	B		U	B
I_{Max} (kA)	+10 / -23	±23	25,7	±26
I^2t (GA ² t)	2		4,6	1.5 (TBC)
Non linear resistor	TBD by the Manufacturer		TBD by the Manufacturer	TBD by the Manufacturer
Seismic Design	Yes		Yes	Yes
Insulating Voltage to Ground	5		2,8	2
Parallel Resistor R (Ohm)	TBD by the Manufacturer			
Ground Resistor R_{GROUND} (kOhm)	1(*)		1(*)	1(*)
Number of operation without maintenance	(*)		(*)	(*)
(*) To be defined during a DDP				

All crow bar units are assumed to be safety relevant components and, then, to be seismic resistant designed. More information on seism spectra at Naka Site are reported in PID Section 1.8.3 (Reference 1). In this case, IEC68-3-3 standard shall be considered and the following reference parameters taken into account the:

- a) *horizontal floor acceleration* = $4.5 \text{ m/s}^2 = 0,45G$
- b) *vertical floor acceleration* = $2.25 \text{ m/s}^2 = 0,225G$

4.2.21. Disconnectors

Each PS must be disconnected from DC Side by no-load disconnecting switches. A proper set of inter-blocks shall be provided to avoid any un-proper operation.

AC disconnectors on the AC input from the secondary sides of the transformers could be added. Depending on the general grounding strategy, these could be or line or grounding no-load disconnectors. The use of AC disconnectors together with their type and operation shall be defined during DDP.

All disconnectors can be operated in both Local/Remote mode (ref. Section 4.7.2.1) and shall be able to withstand the most severe overvoltage/overcurrent.

4.2.22. Compressed air

Industrial standard compressed air will be made available by JAEA (ref. Section 10.5.3) nearby each PS unit. The Manufacturer has the responsibility to:

- connect this apparatus to the JAEA compressed air distribution system;
- adapt it (valves, measurement, filtering, lubrication, drying, pressure value,...) to the specific needs of his apparatus;
- provide its distribution among all devices where necessary.

Enough compressed air shall be stored in the procured apparatus to operate a full cycle open-close-open of all related switches/disconnectors. Pressure level of the stored compressed air and related alarms shall be monitored and made available for SCSDAS/GPS.

4.2.23. Measurement transducers

Transducers have to be suitable for the related measurement and they have to comply with the relevant IEC standards.

A check of transducer internal fault has to be implemented and made available for the control system.

4.2.24. Special Tools and needed equipments for operation and maintenance

The Manufacturer shall provide any special tool necessary for the installation or dismantling of power supplies or part of these (e.g. replacement of a module or of a component inside a module), commissioning (e.g. a printed circuit board simulating faults or measurements) and maintenance.

Heavy components shall be equipped with lifting lugs suitable for supporting their weight (in compliance with IEC standards)

The Manufacturer shall make available all such special tools since the beginning of the installation phase on site. The Manufacturer could use special tools during different phases of the Contract; if use reveals defects or potential improvements to a special tool, the Manufacturer shall modify or improve its performance. After the Final Acceptance Tests on Site, the complete set of special tools shall pass under the ownership of JAEA.

4.3. TF coil power supply (OUT OF SCOPE – Provided by CEA - France)

4.4. PF coil power supplies (PFC PS)

4.4.1. Reference schemes

The PFC PS circuits are shown in Figure 4.4.1-1. Components inside the red shadowed lines are included in the present agreement. . For the insertion in the existing PS system see Figure 4.1.1-4.

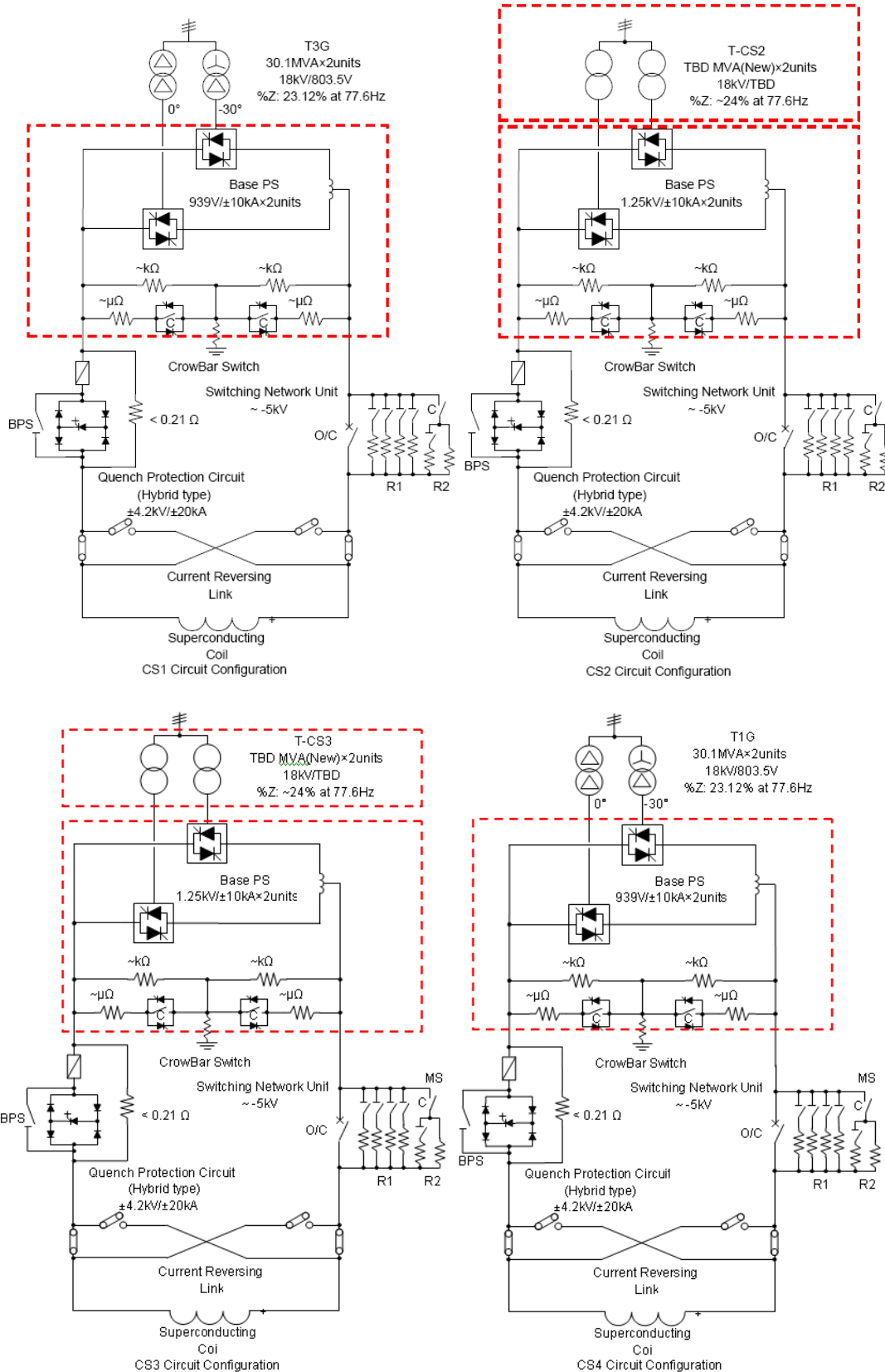

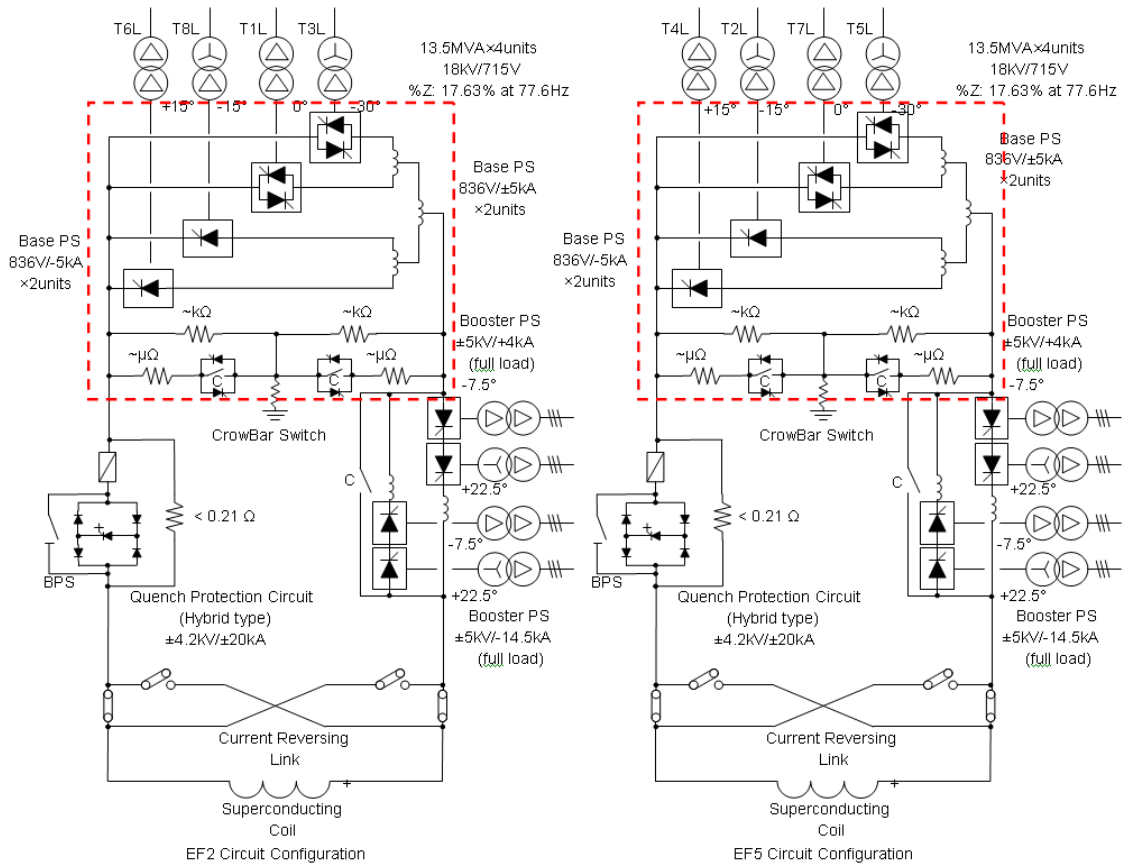
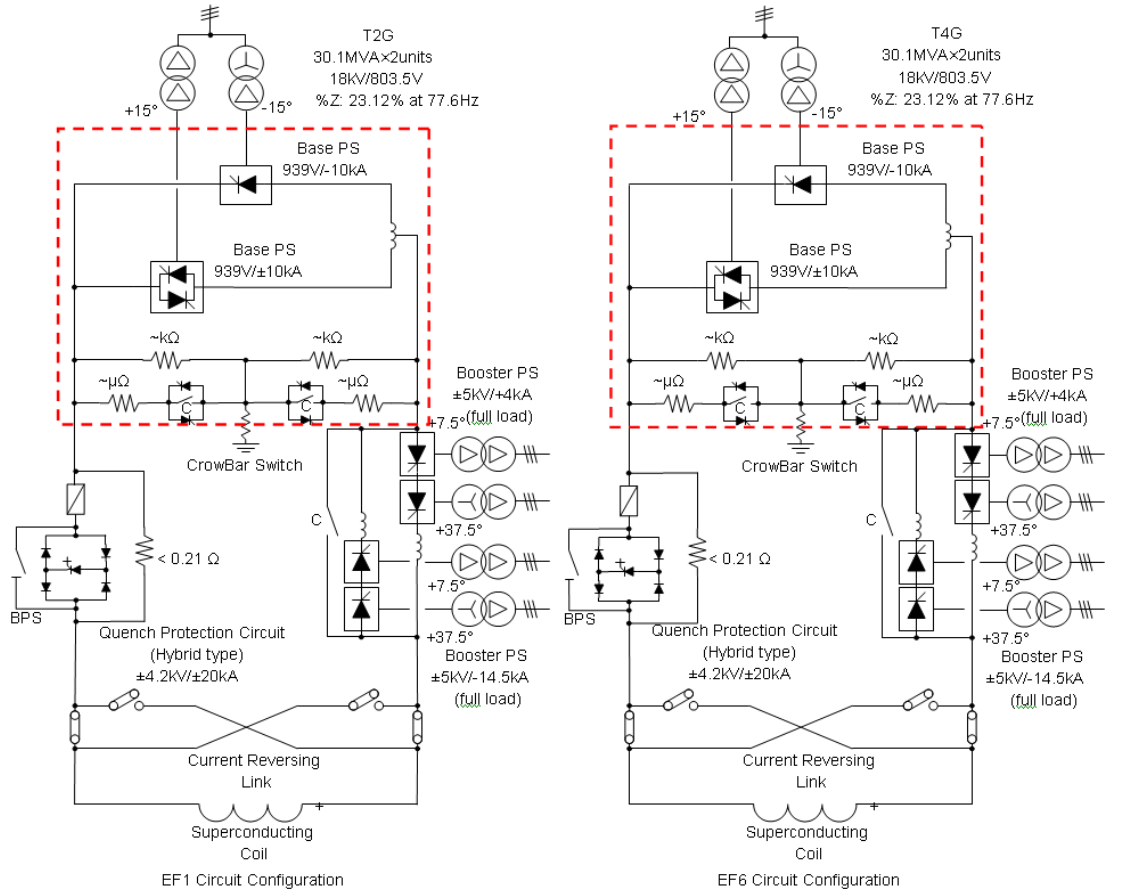

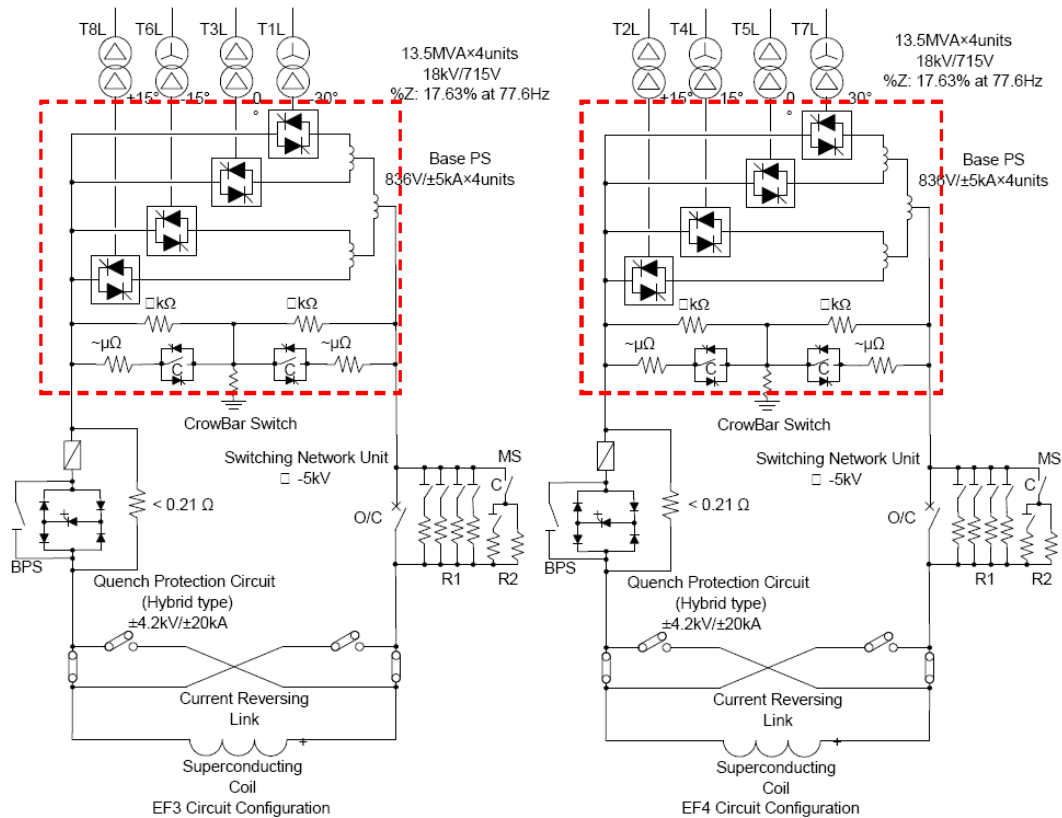

Figure 4.4.1-1 JT-60SA PFC reference schemes

4.4.2. Performances

The main ratings for the power supplies of the PF magnets are summarized in Table 4.4.2 -1

In addition it has to be noted (ref. section 4.4.5) that an electrostatic screen shall be located between primary and secondary windings of the transformer. This has the double scope to reduce stray capacitance and to prevent any contact between the windings in case of insulation failure. For this reason the screen has to be grounded. The Manufacturer shall take care of it during the design of the PFC PS.

Table 4.4.2-1 Reference Design Parameters for PFC power supplies

	V ₂₀ (*1) (kV)	Z(%) (*2)	Frequency range (Hz)	V _{DC0} (*3) (kV)	I _{DC} range (kA)	V _{GND} (*4) (kVdc)	Duty cycle (s/s)
CS1	0.8	23	77,6 – 54,2	1.0	± 2 * 10	5	220 / 1800
CS2	0.96	TBD by the Manufacturer	77,6 – 54,2	1.3	± 2 * 10	5	
CS3	0.96	TBD by the Manufacturer	77,6 – 54,2	1.3	± 2 * 10	5	
CS4	0.8	23	77,6 – 54,2	1.0	± 2 * 10	5	
EF1	0.8	23	77,6 – 54,2	1.0	+10 / - 2*10	5	
EF6	0.8	23	77,6 – 54,2	1.0	+10 / - 2*10	5	

(*1) no load voltage at transformer secondary side

(*2) transformer reactance at 77,6Hz

(*3) no load DC voltage define as 1,35xV₂₀

(*4) Insulating voltage to ground

4.4.3. Operational requirement for PFC PS units

All PFC PSs shall operate in a pulsed mode (duty cycle 220/1800s). The thermal design of converters shall be based on the reference current waveforms reported in Table 4.4.3-1.

Table 4.4.3-1 – Reference waveforms to be used for the thermal design of the converters

Converter	Forward current	Reverse Current
CS1, CS2, CS3, CS4	<p>CS1, CS2, CS3 and CS4 forward current</p>	<p>CS1, CS2, CS3 and CS4 reverse current</p>
EF1, EF6	<p>EF1 and EF6 forward current</p>	<p>EF1 and EF6 reverse current</p>

Each PFC PS shall be designed to be regulated following voltage or current reference signals distributed by SCSDAS and to properly operate with an AC voltage frequency variation from its initial value of 77,6Hz down to 54,2 Hz.

The present section reports the typical operational pulse sequence (ref. Table 1.2-2 in PID) :

- I. Between two plasma shots ($t \ll -40s$) each PFC PS is in a steady state shut-down condition, this means:
 - a) H-MG at nominal voltage and nominal stand-by speed
 - b) all AC HV circuit breakers/disconnectors open
 - c) all DC disconnectors open
 - d) all thyristor convertor blocked
 - e) no reference signals from SCSDAS
 - f) water cooling system in nominal operating conditions and under monitoring
 - g) auxiliaries voltages at nominal values and under monitoring
 - h) compressed air (if present) at nominal value and under monitoring
 - i) safety interlock signals ok and under monitoring
 - j) no alarm/fault signals and situation under monitoring

- II. Just before premagnetization (in the standard scenario, $t < -40s$), SCSDAS:
 - a) checks "ready to operate" condition in each PFC PS (above points a-j ok)
 - b) closed all AC HT circuit breakers

- III. Starting premagnetization (in the standard scenario, $t=-40s$) , SCSDAS:
- unblock CS1, CS2, CS3, CS4 thyristor convertors
 - send the proper load voltage/current reference signals to all thyristor convertors
 - monitor the sequence status and alarm/faults for each PS
- IV. At $t=-10s$: Base PS convertors EF1, and EF6 are unblocked (in the standard scenario) and Booster PSs are also activated simultaneously.
- V. At $t=0s$ (typically) : a voltage step (typically 5kV) across each coil is needed to generate a di/dt load current to induce plasma current breakdown in the JT-60SA vacuum chamber. As this voltage value exceeds PS capability (ref. Table 4.4.2-1) , it shall be produced including in the circuit :
- proper resistors by fast Switching Network Units (SNU) for CS1, CS2, CS3, CS4 PSs
- SNU units are by-passed as soon as the requested voltage across the coil comes again inside the PS capability limit and, in any case, for SNUs, before load current crosses zero.
SNUs are not included in the present procurement.
- VI. Ending of the plasma shot (typically $t=210s$) : SCSDAS set again the system in a steady state condition (point I, above)

It has also to be underlined that Quench Protection Circuits (QPCs), not included in the present procurement, are by-passed during a normal pulse. They are operated to protect each superconducting coil in case of internal quench (when the coil is not longer superconducting and becomes normal conducting). QPCs includes in the circuit an additional resistance to generate a fast ramp down of the load current. At the nominal current, the QPCs resistance generate a voltage drop of about 5kV.

In any case, together with QPC operation the converter current ramp-down and the crowbar operation shall be always required.

The Manufacturer shall demonstrate the PS ability to properly operate in this condition, also on the basis of his own experience. The proposed design shall be discussed and agreed during the Detailed Design Phase.

4.4.3.10 CS1, CS2, CS3 and CS4 PFC PS converters operating mode

As shown in Figure 4.4.1.-1 these PS are fed through already existing 30MVAx2 units transformers (CS1 and CS4 PSs), or by new transformers included in the present procurement (CS2 and CS3 PSs). Each PS unit is composed by two 10kA, 6-phases thyristor bridges. These bridges will be indicated as Converter 1 and 2, respectively. In order to maintain a minimum level of current in converters and avoid having a time delay in reversing current direction, 3 operating modes are needed for the PF PS (Figures 4.4.3.1-1) :

- circulating current mode
- single mode
- dual mode

Transition mode area will be finally fixed in the DDP.

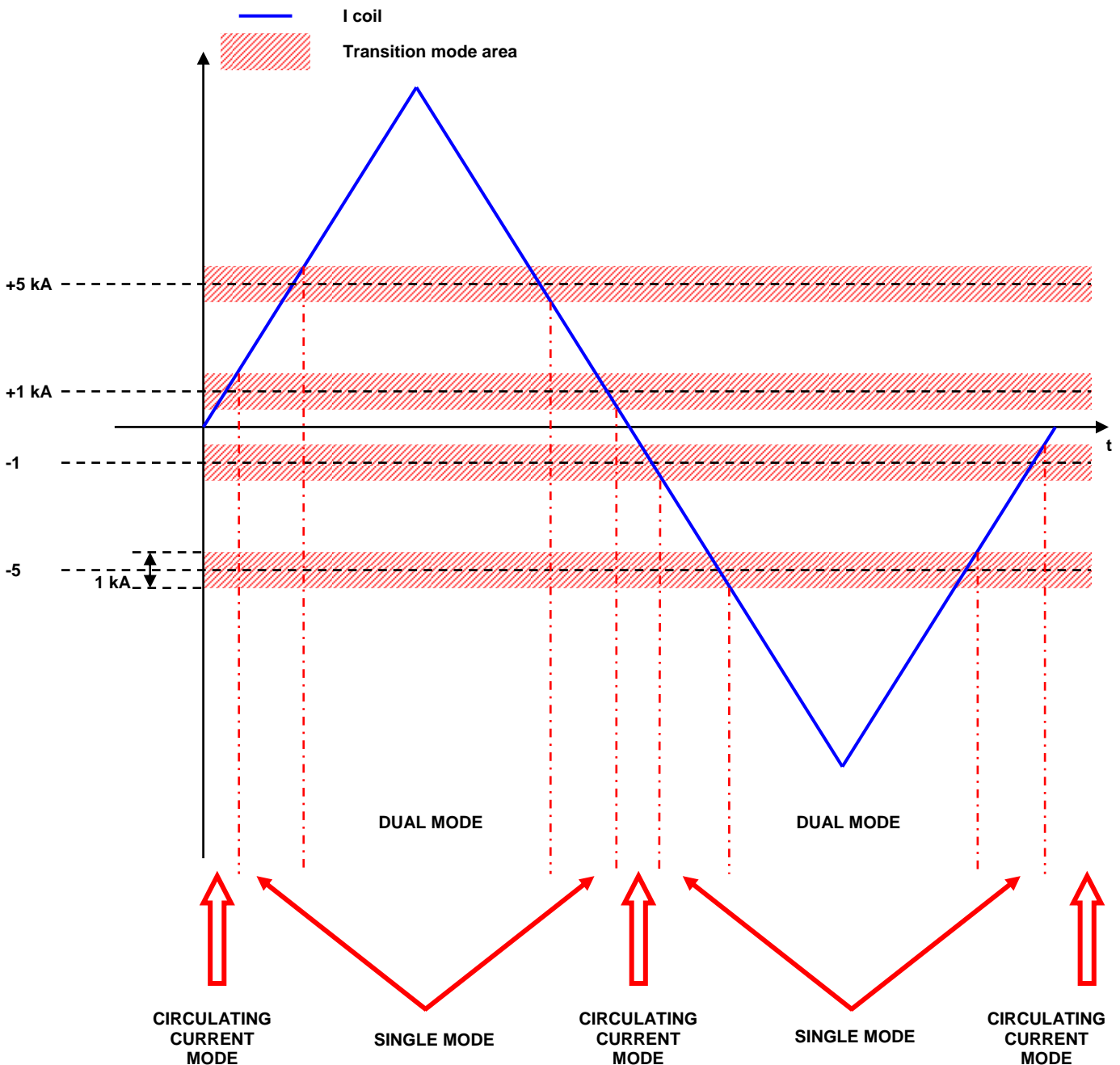

Fig. 4.4.3.1-1 CS1 - CS4 Converter Operation Modes with respect to Load Current

In Figures 4.4.3.1-2 and 4.4.3.1-3 the 3 operating mode are described is showed current way in the converters according to operation mode

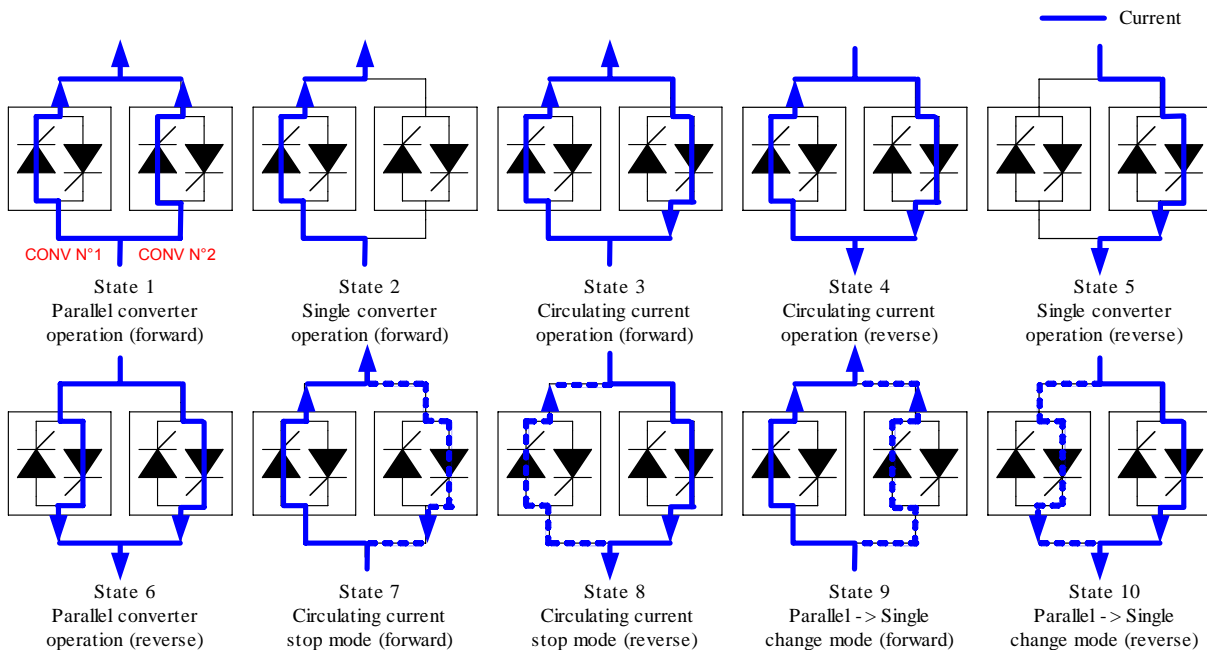

Fig. 4.4.3.1-2 CS1-CS4 Current path inside the converter during different operation mode

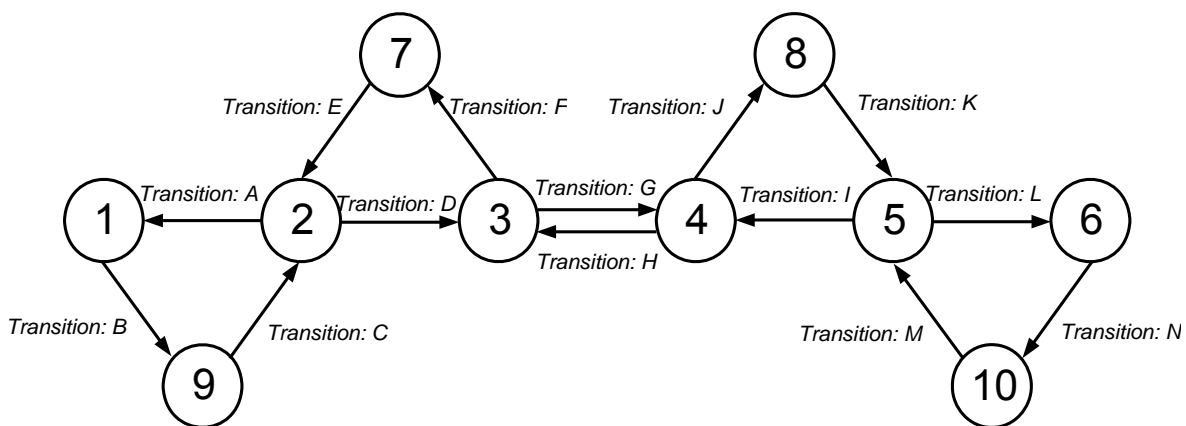

Fig. 4.4.3.1-3 CS1-CS4 Synthesis of the converter operation modes

As already reported, SCSDAS will distributed load voltage/current reference scenarios. To properly operate the converter in the above mentioned modes, suitable internal reference signals for Conv. 1 and Conv.2, respectively, have to be generated. The action to generate the internal reference signals starting from those ones distributed by SCSDAS is under the Manufacturer responsibility, on the basis of his own experience. A proposal shall be provided by the Manufacturer and discussed/agreed during the Detail Design Phase

4.4.3.11 EF1 and EF6 PFC PS converters operating mode

As shown in Figure 4.4.1-1, these PS are fed through already existing 30MVAx2units transformers and are composed by two units : the first composed by two 10kA, 6-phases thyristor bridges (Converter 1), the second one composed by only one 10kA, 6-phases thyristor bridge.

Figures from 4.4.3.2-1 to 4.4.3-3 are reported with the same meaning of the respective ones in Section 4.4.3.1. Transition mode area will be finally fixed in the DDP.

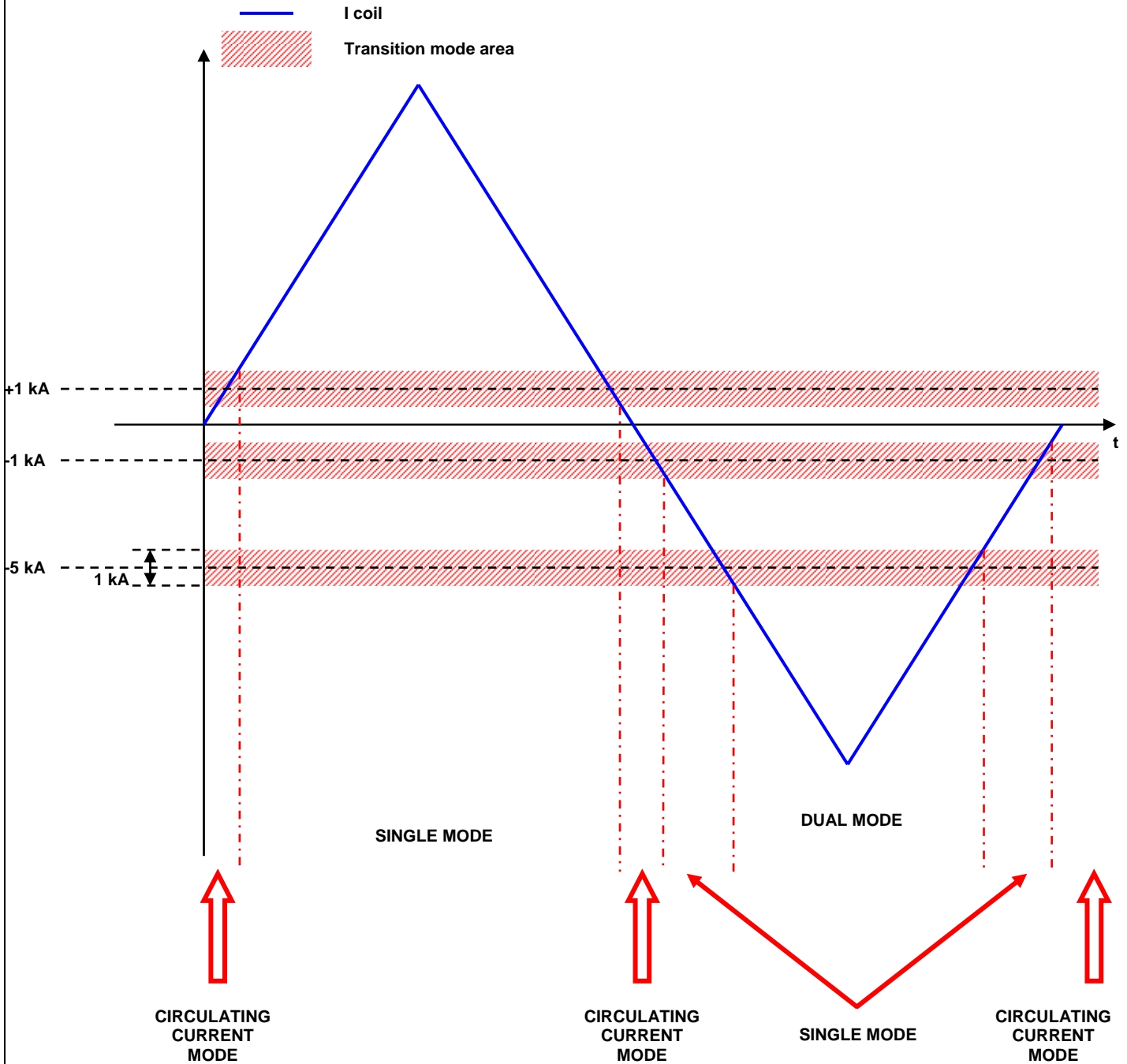

Fig. 4.4.3.2-1 EF1, EF6 Converter Operation Modes with respect to Load Current

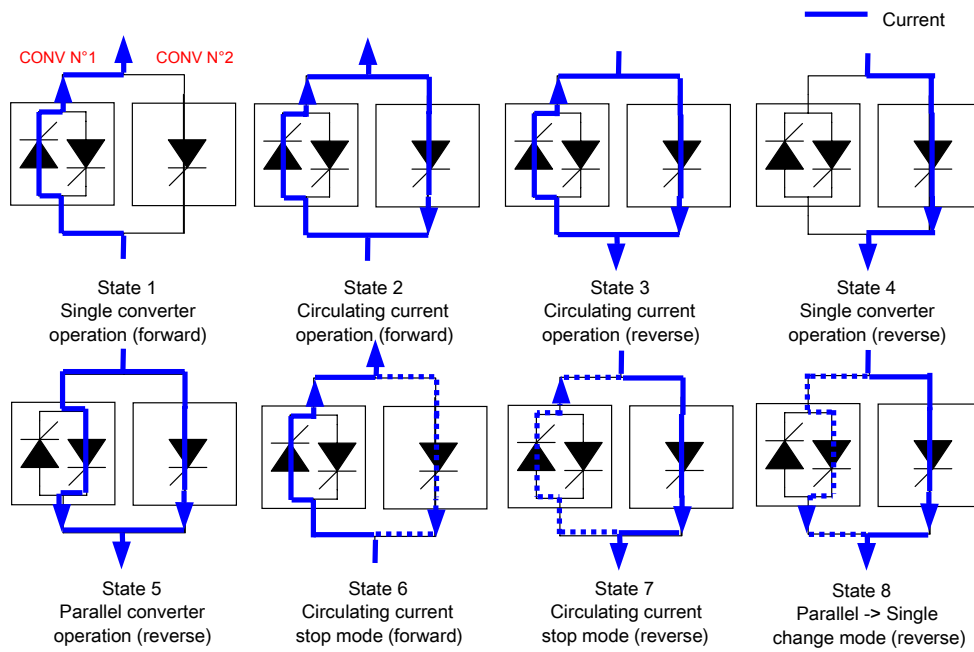

Fig. 4.4.3.2-2 EF1,EF6 Current path inside the converter during different operation mode

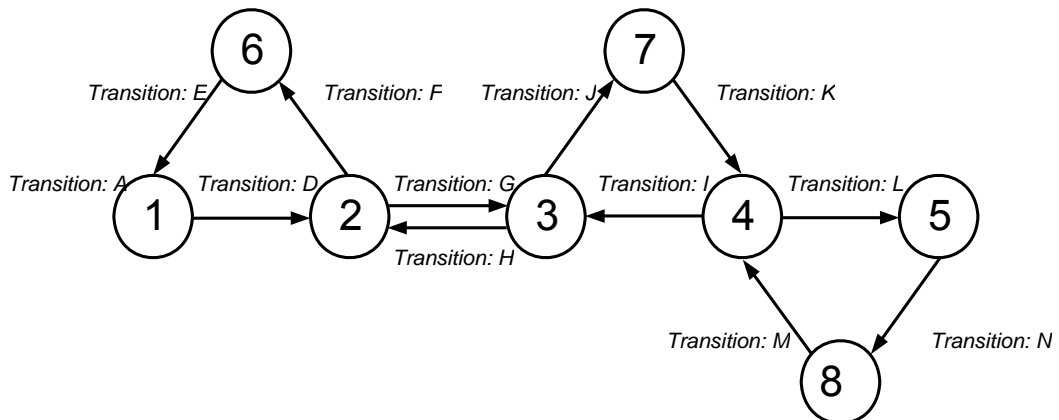

Fig. 4.4.3.2-3 EF1, EF6 Synthesis of the converter operation modes

4.4.3.12 EF3 and EF4 PFC PS converters operating mode (**OUT OF SCOPE – Provided by CEA - France**)

4.4.3.13 EF2 and EF5 PFC PS converters operating mode (**OUT OF SCOPE – Provided by CEA - France**)

4.4.4. Thyristors cubicle design

Thyristor converters shall be designed in agreement with IEC standard 60146.

Selection of operating current and voltage of the thyristor valves, and related safety margins, as well as of its gating, cooling and clamping procedures shall be performed fully in agreement with thyristor's manufacturer recommendation and related application notes. This shall be demonstrated by the Manufacturer in the First Design Report (ref. section 8.1.1).

PFC PS are 4 quadrants converters (with circulating current), 12 or 24 pulses (depending on number of transformer secondary winding) except in single mode.

They are demineralised water cooled converters including crowbar unit.

The Manufacturer shall proposed a reference design (thyristor type, fuse or fuseless, layout, IP code...) on the basis of his current practice, fully complying with the present specifications and with all IEC relevant standards. In particular:

- the mechanical structure of the cubicle shall be demonstrated to withstand the most severe electromechanical stressed deriving by the most demanding conditions,
- in case of thyristor explosion, this must be confined inside the cubicle without any risk for operators,
- crowbar cubicle shall comply with seismic requirements (ref. Section 10.2) such as internal DC feeders to allow a continuous circuit till the current goes down to zero.

4.4.5. Transformers

New transformers are required only for CS2 and CS3 coils power supplies.

The main characteristics foreseen for CS2 and CS3 PF PS transformer are shown in Table 4.4.5-1.

Table 4.4.5-1 Reference design Parameters for CS2/CS3 PS transformers

CS2/CS3 Transformer Main Parameters	Value
Type	Three windings
Winding Electrical Connections	Ddy11
RMS Current at each secondary winding (kA)	8,16
Voltage Ratio (kV/kV)	18/ 0,96
Z _{12,13} (%) at 77,6 Hz	TBD by the Manufacturer
Z ₂₃ (%)	Magnetically decoupled
Frequency Operating Range (Hz-Hz)	77,6-54,2
Insulating Voltage to Ground	Ref. IEC 60076
Insulation medium	Mineral oil (ref. Section 4.2.7)
Duty Cycle (s/s)	220/1800

At least, each transformer shall have the follow protective/monitoring devices :

- Over current vs time relay
- Thermal relay
- Buchholz relay

- Temperature monitor - indicate temperature in the transformer's topmost oil layer with maximum and minimum signal contacts
- Oil level alarms
- Oil flow indicator (in the case of forced oil circulation)
- Airflow indicators (only for fan cooled transformers)

The HV and LV transformer insulators shall be protected with an IP52DH (Sections 4.2.11) enclosure. For the noise limit see Section 4.2.6

In any case the transformers have to be complying with IEC 60076 and IEC 61378 for design, construction and tests.

The Manufacturer can propose a design solution different from the reference one. Moreover in this case, the Manufacturer shall prove the convenience of the alternative solution proposed which shall be evaluated/agreed during DDP before to be adopted.

4.5. FPPC coils power supplies

The power supplies for upper/lower FPPC coils have the function of control vertical and horizontal position of the plasma against small plasma perturbation or a minor disruption. To maximize the control range with small cross section of the in-vessel lower and upper control coils, a 12 pulses / 4 quadrant / circulating current thyristor converter is required. Operational Requirements in Section 4.4.3 are also applicable to these power supplies.

The reference scheme is the following fig. 4.5 – 1:

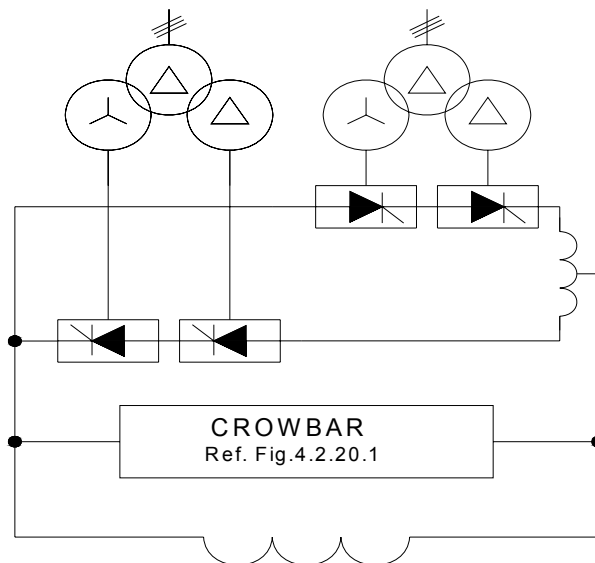

Fig 4.5-1 Reference scheme for FPPC coil PS

4.5.1. Performance and operational requirement

The main performances/parameters of FPPCC PSs are summarized in Table 4.5.1-1.

In addition it has to be noted (ref. section 4.5.2) that an electrostatic screen shall be located between primary and secondary windings of the transformer. This has the double scope to reduce stray capacitance and to prevent any

contact between the windings in case of insulation failure. For this reason the screen has to be grounded. The Manufacturer shall take care of it during the design of the entire FPPCC PS.

In the case of major plasma disruption a current will be induced in the FPPC coils with a maximum, estimated value of ~21 kA (Figure 4.5.1-1). This current is not expected to flow inside the thyristor converters as crowbar unit is expected to be operated or by GPS or automatically by BOD as high impedance of the PS may cause over voltage in the coil.

The main characteristics of FPPCC PSs are summarized in Table 4.5.1-1

Figure 4.5.1-1 Reference Design Parameters for FPPCC PSs

FPPCC PS Main Parameters	Values
Vdc0(kV) (*1)	$\pm(2*0.5)$
Idc (kA)	± 5.0
Duty cycle (s/s)	140/1800
Current accuracy (%) (*2)	± 1
Insulating voltage to ground	2kVdc (TBC)
Operation	4 quadrant
Pulses	12
Converter cooling system	Demineralized water
(*1) no load voltage	
(*2) Referred to nominal value	

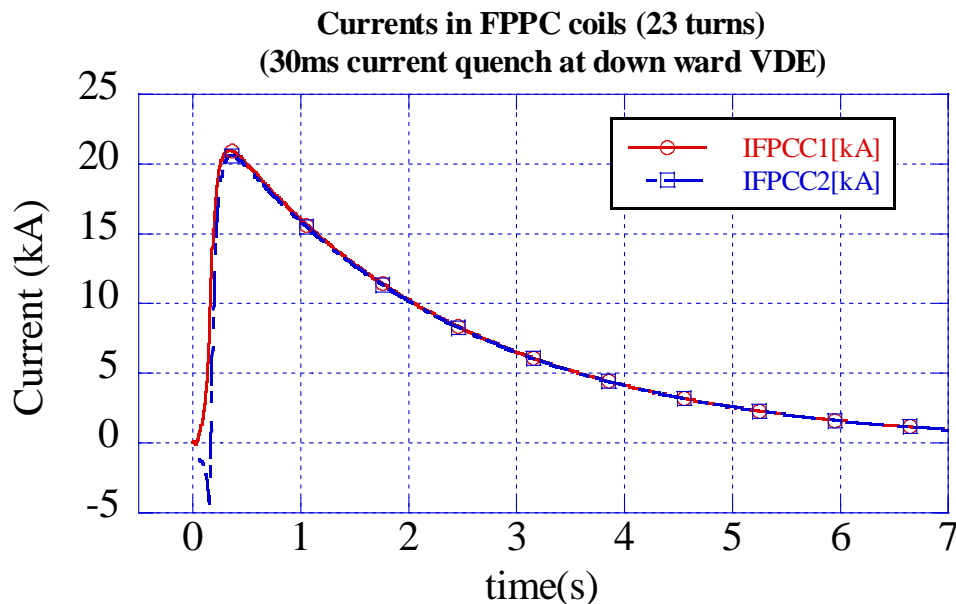

Figure 4.5.1-1 Estimated induced current inside upper/lower FPPC coils

4.5.2. Transformers

New transformers are required only for FPPC upper and FPPC lower coils power supplies.

The main characteristics foreseen for FPPC-upper and FPPC-lower coils PS transformers are shown in Table 4.5.2-1.

The transformers shall have the follow protective devices at least:

- Over current vs time relays

- Thermal relays
- Buchholz relays (in case of oil insulation)
- Temperature monitor - indicate temperature in the transformer's topmost oil layer with maximum and minimum signal contacts (no for dry type)
- Oil level alarms (in caser of oil insulation)
- Oil flow indicator – (in case of oil insulation and forced oil cooling)
- Airflow indicators (only for ONAF and dry type transformer)

The HV and LV transformer insulators shall be protected with an IP52DH (Sections 4.2.11) enclosure. For the noise limit see Section 4.2.6

In any case the transformers have to be complying with IEC 60076 and IEC 61378 for design, construction and testing .

The Manufacturer can propose a design solution different from the proposed reference one. Moreover in this case, the Manufacturer shall prove the convenience of the alternative solution proposed which shall be evaluated/agreed during DDP before to be adopted.

Table 4.5.2-1 Reference Design Parameters for FPPCC PSs Transformers

FPPC PSs Transformer Main Parameters	Value
Type	Three windings
Winding Electrical Connections	Ddy11
RMS Current at each secondary windings (kA)	4
Voltage Ratio (kV/kV)	18/ 0,39
$Z_{12,13}$ (%) at 77,6 Hz	TBD by the Manufacturer
Z_{23} (%)	Magnetically decoupled
Frequency Operating Range (Hz-Hz)	77,6-54,2
Insulating Voltage to Ground	Ref. IEC60076
Insulation medium	Oil/dry transformer type (TBD)
Duty Cycle (s/s)	140/1800

4.6. PS interfaces requirements

Figure 4.6-1 shows the interfaces of each unit of PSs coils with respect to the other parts of JT-60SA systems. In the scheme. Interfaces are represented with circles. The colours of the interfaces indicate the respective procurement responsibility. The colour of the line which connects two interfaces indicates the organisation providing the physical connection between the interface points.

Electrically, each Power Supply (PS) will interface with the following items:

- 1) PFC and FPPC coils;
- 2) the ac HV distribution systems;
- 3) the ac LV distribution system;
- 4) the dc voltage distribution system;
- 5) the grounding network.

Moreover, each PS will be interfaced with:

- 2) the compressed air distribution system;
- 3) the site water cooling system;
- 4) the building and the respective facilities

Each PS will include also a Local Control Cubicle (LCC), which will exchange signals with:

- 1) the JT-60SA supervising control system (SCSDAS);
- 2) the Global Protection System (GPS) for the protection and alarm detection signal.
- 3) The safety interlock system

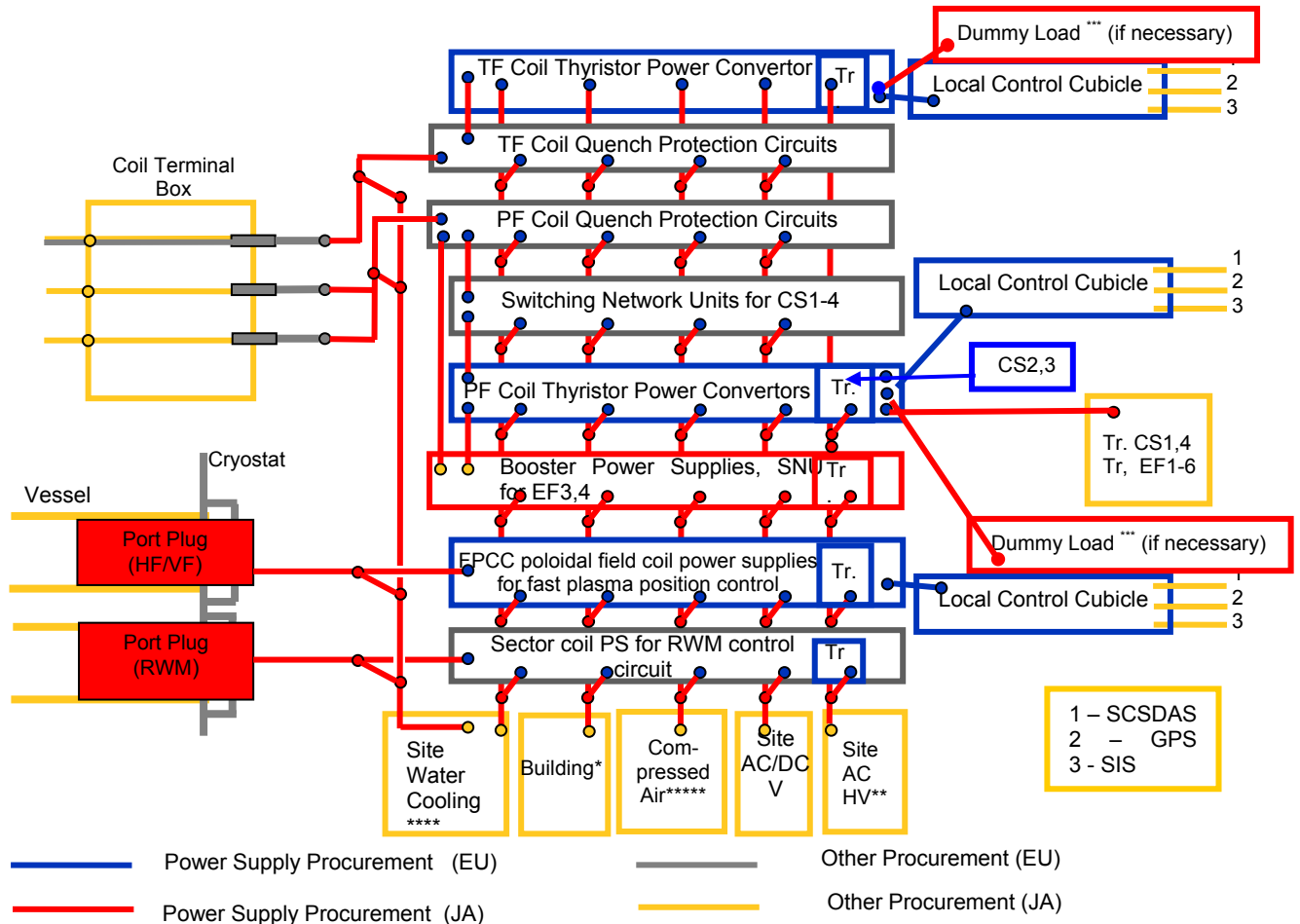

Fig. 4.6-1 Overall view of interfaces between PS and the other JT-60SA systems

4.6.1. Interfaces with other units of the dc power circuit

The interface between each PS and the respective other power units (SNU, QPC, Booster, etc.) is identified by the connection of the cables / busbars to the PS power terminals.
The Manufacturer shall provide the PS power terminals.

JAEA provides the power cables / busbars which connect the other power units to the PS and connects them at the PS power terminals.

The position and the features of the PS power terminals shall be agreed between F4E and JAEA during DDP.

4.6.2. Interfaces with APS low voltage distribution system

The Auxiliaries Power Supplies (APS) of the power and control sections of each PS shall be fed from the JAEA Low Voltage Distribution System (Section 10.3), which provides Normal and Un-interruptible ac & dc APS. The electronics of both LCC and power section will be supplied by the Un-interruptible APS of the JAEA Low Voltage Distribution System, such that the PS operation is assured even in case of total or partial loss of mains voltage. The expected power to be requested to the APS is shown in table 4.6.2-1. Final values shall be defined during DDP.

Table 4.6.2-1 Available power for APS

	Available power for each PS	Total available power
400 V AC normal APS (kVA)	10	130 kVA
400 V AC Un-interruptible APS (kVA)	1.5	19.5 kVA
100 V DC Un-interruptible APS (kW)	2	26 kW

The interface between the PSs and the JAEA ac low voltage distribution system is identified by the connection of the low voltage supply cables to the PS terminals.

The Manufacturer shall provide the PS internal distribution of the low voltage supply.

JAEA provides the low voltage distribution board including the circuit breakers; provides and lays down the low voltage supply cables up to the PS and terminates them at the PS cubicles.

4.6.3. Interfaces with the compressed air distribution system

The JAEA compressed air distribution system is described in Section 10.5.3

Other requirements are reported in section 4.2.22. Final air compressed requirements shall be defined during DDP.

The interface between each PS and the compressed air distribution system is identified by the termination of the pipes in the PS CB cubicle. Termination type shall be defined by JAEA within the end of the DDP.

If needed, the Manufacturer shall provide the PS internal circuit for compressed air and the pipes for the connection to the JAEA local distribution system.

In this case, JAEA provides pipes close to the PS CB cubicles and makes the connection between the local compressed air distribution system and the PS pipes.

4.6.4. Interfaces with the site water cooling system

JAEA will provide rough cooling water and demineralised cooling water for Aluminium components with the characteristics reported in Table 4.6.4-1. If the demineralised cooling water distributed by JAEA will be used, the list of materials to be used in the water cooling system shall be agreed during the DDP. If an internal closed loop demineralised water cooling circuit will be used, this will be connected through an heat exchanger to the JAEA water cooling system. The expected cooling requirements to be requested to the JT-60SA water cooling system for each PS (included CB and interphase reactances) unit are:

Table 4.6.4-1 Main characteristics of demineralised water for Aluminium Components

Flow rate (Q)	24m ³ /h for PFC 21 m ³ /h for TFC
Water input temperature (Tin) during operation	20°C ≤ Tin ≤ 35°C
Input water minimum temperature (in transient situation such as during start-up period)	5°C
Max. temperature variations (ΔTin,out)	10°C
Water input pressure (Pin)	450 kPa ± 100 kPa

Max. pressure fall ($\Delta P_{in,out}$)	250 kPa
Water resistivity (ρ)	$\geq 1M\Omega \cdot cm$ @45°C
Type of water pipes	Stainless Steel

For each one of the 13 PSs included in the present procurement (1 TFC PS, 4 CS Coils PSs, 6 EF Coils PS and 2 FPPC Coils PS), the expected losses to be cooled down by the demineralised water cooling system are estimated as 250kW. The final value shall be agreed during DDP.

The boundary between PSs and JT-60SA water cooling systems is defined by two terminations per converters, made with flanges (to be defined by JAEA within the end of the design phase), for inlet and outlet water cooling respectively. Such flanges shall be placed on each PS, in a position to be defined/agreed during the DDP .

JAEA provides the water cooling pipes connecting the PSs, with the respective flanges, and connect them to the flanges provided by the Supplier.

4.6.5. Interfaces with the grounding network

Grounding indicates the connection point/bus to the earth grid of the site. The interfaces between the PS internal grounding system and the JAEA grounding network are the ground terminal in each PS converter. The type of termination shall be agreed during the DDP. JAEA will connect the ground terminal of each PS converter to the closest terminal of the ground network of the building.

4.6.6. Interfaces with the SCSDAS, GPS and SIS

To allow a proper monitoring of the SCMPS System together with all needed protective actions, each PS is interfaced with SCSDAS, GPS and SIS by means of signals that can be grouped in:

- slow signals (frequency updating TBD at DDP):
 - interface with the SCSDAS, for System Monitoring
 - interface with the “Safety Interlock System” (SIS)
 - slow measurements as temperatures, flows,...
- fast signals (frequency updating TBD at DDP):
 - interface with the SCSDAS for Timing, Data Acquisition and Real Time Control Systems
 - interface with the “Global Protection System” (GPS)
 - fast measurements as coil currents and voltages, references,...
 - alarms

Details of both slow and fast signals together with the connection interfaces shall be agreed during DDP.

4.7. Thyristors converter regulation / Control and protection system

4.7.1. Thyristor convertor regulator

To achieve the requested performance (ref. Sections 4.3, 4.4 and 4.5), each TFC, PFC and FPPCC PS shall include dedicated PI regulator. As already mentioned, these PSs can be controlled either by a reference current signal or by a voltage one.

In principle regulator shall be a digital and programmable units already well experimented inside industrial environment. In particular the Manufacturer shall demonstrate that the whole regulating system (regulator with its correlated interfaces, measurements, transducers,...) is able to properly operate in a variable frequency range 77,6-54,2 Hz and in the system configuration shown in Section 4.2.1, 4.3, 4.4 and 4.5. The Manufacturer shall include inside each regulator logic all the operational/protective actions needed to achieve the requested performances. In particular, the minimum and maximum firing angle shall not be constant value, but shall be optimised depending on the actual converter current and frequency of AC source voltage.

The regulator should operate with different internal cycles : the fastest cycle (<0,5 ms) for protection, the average cycle (typical 0,5 ms) for the calculation of firing angle updating (total maximum updating time is within the range 1,5-3,6ms depending on the actual AC frequency and on the actual converter operation mode) , the slowest cycle (typical 2 ms) for signal communications and logic.

4.7.2. Control and protection system

Each TFC, PFC and FPPCC PS unit shall include a dedicated Control and Protection System installed in a Local Control Cubicle (LCC) placed close to each power unit.

4.4.3.14 Local / Remote control modes

The Control and Protection System shall allow operating each PS unit either in "Remote Control" or in "Local Control" mode. A "Remote/Local" key switch shall be provided for each LCC panel to switch between the two modes of operation. The status of Remote/Local shall be monitored from GPS or SCSDAS in any time.

Signals from/to Safety Interlock System are not affected by the Local/Remote Control key switch.

PS will normally be operated in "Remote Control", under the control of the JT-60SA SCSDAS, SIS, GPS. However, it shall be possible to operate in "Local Control" for the purpose of testing, trouble-shooting and commissioning of each PS.

To allow "Local Control" a proper Human/Machine Interface (HMI) shall be available on each LCC including, in particular, a reference generator . In "Local Control Mode" commands from SCSDAS or GPS shall be ignored. In "Remote Control" the PS shall be operated only from SCSDAS and any command set locally shall be ignored.

In principal, in "Local Control", it shall be possible to completely operate and monitor the PS unit; moreover, it shall be possible to perform all Final Acceptance Tests on Site as specified in Section 5.3.

Precise definition of the PS operation in Local/Remote will be agreed with during the DDP on the basis of a proposal by the Manufacturer.

4.4.3.15 Function of the protection and the control system

The main functions of the Control and Protection System installed in the LCC are to :

- operate the PS units in order to achieve the requirements of this specification and perform monitoring, handling and logging of alarms and collection of data and measurements from the Local Control sub-units;
- integrate and complete, if necessary, the action of the converter internal protection ;
- provide a HMI that permits to supervise the status of each PS as : local testing; trouble-shooting; monitoring, handling and logging of alarms and collection of data from the PS unit;
- exchange data and signals with the SCSDAS, including command / status for the execution of sequences and measurement for data acquisition;
- send fault/alarm signals to the GPS and to receive the operation command from the GPS;

- exchange signals with the SIS

To comply with this scope, each LCC shall include:

- a Human Machine Interface (HMI); the HMI shall allow a friendly high-level man-machine interface with graphic mimics of the PS unit. The related hardware and the specific functions will be agreed during the DDP.
- Proper programmable devices and related I/O interfaces for proper managing of all slow signals, all commands, all alarm/faults handling, all slow interlocks, local/remote changeover facilities, etc.. Safe Fail (including I/O interfaces) logic shall be used in any case depending on the different signals and the related functions different devices (slow or fast for alarm/fault) can be proposed by the Manufacturer. If only one type will be proposed, its performances shall comply with the fastest signals
- interfaces with the JAEA SCSDAS as described in Section 4.6.6

Communication with the SCSDAS shall be based on Ethernet TCP/IP (TBC during the DDP) or Reflective Memory (RM). In principal all signals used only during plasma shot will be communicated from/to SCSDAS using RM, GE (General Electric) type is required. The other ones using ETHERNET. The final choice, together with the communication protocol shall be agreed during the DDP .

4.4.3.16 *Protection*

Converter regulator shall perform protective action of the PS in case of a number of cases (internal fault, overcurrent, , shoot-through,...) together with other protective actions directly performed on some specific components (i.e converter transformers, cooling system,...). In any case LCC shall include all I/O interfaces for communications to SCSDAS/GPS/SIS.

The final list of alarm together with the expected protective actions shall be agreed during the DDP.

4.8. Layout , assembly, installation and commissioning requirements

JT-60SA will be located at JAEA NAKA Fusion Institute. Most of the existing building infrastructure, available for the JT-60U devices, will be re-used for JT-60SA. Detailed layout shall be agreed during DDP.

F4E shall be responsible for all the assembly, installation and commissioning actions on Site.

Before the start of the installation phase, JAEA will make available all the areas where the PS systems will be installed. JAEA will make also available all utilities needed during assembly, installation, testing and commissioning phases. Details shall be agreed during DDP.

Transportation from possible temporary storage areas to final installation room shall be performed by JAEA. F4E shall be responsible for components final positioning. No crane is available in the areas where the PSs will be installed.

Installation on Site shall be regarded as completed when all components included in the present PA will be installed and ready for Site acceptance tests. An official note on completion of installation shall be prepared and approved by representatives of the Manufacturer and of both IAs

5. TESTING AND APPROVAL REQUIREMENTS

5.1. General requirements

The whole of the provided equipment shall be subjected to inspection and test to prove the compliance with the Technical Specification (TS) during manufacture at the Manufacturer's Facilities, and during erection and on completion at the JT-60SA Site. Tests have to be performed in agreement of the relevant IEC standard (routine tests) and including what is requested in the present section. Specific acceptance criteria are indicated if IEC prescription could not be clearly identified. Sections 5.2 and 5.3 describe a preliminary list of the tests to be performed and the relevant test conditions referring to the reference design. Final tests list shall be agreed during the DDP after the completion of the detailed design. A Detailed Testing Plan, including procedure and related time schedule of all Factory Tests and Final Acceptance Tests on Site, shall be made available by F4E and agreed with JAEA at least two months before the starting of testing.

F4E and/or JAEA representative, and/or the Project Leader or their delegated persons, may witness all the Type and Routine Factory Tests. Report of all tests (including all records, certificates and performance curves performed during testing procedures) shall be included in the Test Report.

Before any equipment is packed or dispatched to Naka Site, all Factory Tests shall have been successfully carried out in the presence of F4E and/or JAEA and/or the Project Leader or their delegated persons, unless otherwise agreed in the Testing Plan.

Any item of equipment or component which fails to comply with the requirements of this specification in any respect or at any stage of manufacture, or test, shall be rejected either in whole or in part as considered necessary. After adjustment, modification or repair, if so directed agreed, the component shall be submitted to further relevant inspection and/or tests.

Equipment or components with defects of such a nature that the technical specification's requirements cannot be fulfilled by adjustment or modification, shall be replaced by F4E and tested again at his own expense to prove the compliance with the TS.

5.2. Factory Test of Power Supplies Units

These tests concern type test and routine test which shall be made on each PS. All tests will be carried out in the Manufacturer's premises unless this is not possible. In this case they shall be carried out in another suitable test facility agreed during DDP.

All equipments supplied under this contract shall be subjected to relevant routine tests (including withstanding voltage to ground and tightness on compressed air and cooling water circuits) as specified in both the relevant IEC Standard and to all additional tests reported in this specification. Manufacturer could propose to make acceptable certified copies of type test regarding equipment of identical design, rating and construction. This shall be agreed among F4E and JAEA and the PL or their delegated persons.

In the following additional Factory Tests are described for different component used in the different type of power supplies. As the same components could be installed in different PSs, it could be agreed during DDP to perform the related Tests for that component only one time (in that case the most stringent test requirements shall be applied). In any case power tests shall be performed on each PS.

5.2.1. PS (Thyristors Cubicle including interphase reactances and and Crow bar switch)

- a) *Test to verify the DC Current Power Supply Performances* - These tests have the scope to demonstrate the PS' capability (by both electrical and thermal points of view) to comply with the requirements of these Technical Specifications. As this could be performed in different ways, the detailed testing procedures, together with related acceptance criteria, shall be agreed during DDP.
- b) *Functional test* - Functional tests shall include, at least:
 - i. visual inspection (including maintainability and grounding),
 - ii. checking of converter regulator, gating logic, supervisory logic and protective control.
 - iii. Auxiliaries

- iv. Compressed air : the whole circuit shall withstand tightness test at P = 2,4MPa lasting 6 hours
- v. Cooling water : the whole circuit shall withstand tightness test at P = 850kPa lasting 6 hours
- c) *Seismic Tests (for crowbar units only and related auxiliaries)* - Crowbar units are considered to be safety relevant equipments and, therefore, to be seismic resistant designed (ref. Section 4.2.20). As all these units are assumed to be identical, a type test shall be performed on one crowbar unit, and related on board auxiliaries, to demonstrate (for example using "hammer tests" or other suitable system to be agreed during DDP) that its own natural frequency is far away from the expected seism frequency (Reference Document 1, PID, section 1.8.3)

Functional tests shall be performed in agreement with relevant IEC standards, if existing. In any case, a detailed list of functional tests together with related acceptance criteria shall be agreed during DDP.

5.2.2. Control and regulation cubicle

All equipment shall be fully tested to check they fully comply with the functional requirements of this specification and performs the operations for which it was designed.

The Functional test shall be performed on the Local Control Cubicle (LCC) and shall consist of a comprehensive series of measurements of the characteristics of the equipment to check that its performance is in accordance with the requirements of this specification and performs the operations for which it was designed.

The safe and correct operation of all protective circuits and the overall protection coordination shall be checked.

5.2.3. Transformers

All tests for the transformers, object of this Technical Specification, shall be made in accordance with IEC 60076-1,2,3 for oil-immersed transformers, and IEC 60076-11 for dry-type transformers, unless otherwise specified in IEC 61378.

5.3. Final Acceptance Tests on Site

Final Acceptance Tests on Site shall include :

- a) *Visual Inspection Tests*
- b) *Withstand Voltage to Ground* - These tests are shown in Table 5.3-1 and they regard, separately, each complete PS, excluding auxiliaries systems (that have to be properly separated) and the related transformers

Table 5.3-1 : Withstand Voltage to Ground (kVac, 50Hz, 10min) for Final Acceptance Tests on Site

Components	CS1,4 PS	CS2,3 PS	EF1,6 PS	FPPC PS
Complete converter (*)	1,62	1,87	1,62	1.5
Transformer (**)	-	22.5/1.44	-	22.5/1.17

- c) *Load Tests* - Load test should be performed using the dummy load made available by JAEA. Details shall be agreed during the DDP. It could be agreed by JAEA and F4E to substitute this test by a short circuit test.

In case of test on the JAEA dummy load, JAEA will:

- Handle the dummy load
- Provide the needed cables between the converters and the dummy load
- Install the connections

In case of a short circuit tests, the short circuit connections will be provided and made by the Supplier

- d) *Functional Tests*: tests reported in Section 5.2.1c shall be repeated otherwise differently agreed during the DDP

All previous tests shall be performed at the presence of representatives of both Implementing Agencies. An official note will confirm the satisfactory completion of the delivery associated to this Procurement Arrangement.

Final acceptance by PL shall be carried out with submitted document of the summary of field test results.

6. CODES AND STANDARDS

The Design, Manufacture and Testing of all equipment supplied shall be in accordance with the most updated version of the relevant IEC Standards and Regulations.

7. PACKAGING AND TRANSPORTATION REQUIREMENTS

Delivery and transportation to Naka Site shall be performed in agreement with Art.5 of the present PA. Handling, packaging and transportation to Naka Site, of all components included in the present PA, have to be performed according to procedures insuring minimising the risk of damage to the components. Storage has to prevent any possibility of contact with any contaminant agent. Performing action under his responsibility, F4E will select, on his convenience, number, size and identification of the delivered packages. JAEA shall be informed about these details before transportation to Naka Site.

To be considered ready for transportation, components shall be inspected at the Manufacturer premises to verify the respect of the requirements for transport. The Inspection shall consist in a visual verification of the packaging, including shock recorder/acceleration sensors, and of a review of the formal and technical documentation for transport. The inspection and documentation verification shall be performed at the presence of representatives of the Manufacturer and of both Implementing Agencies (IAs). An official note of the inspection shall be prepared and approved by the representatives. JAEA shall be responsible to make available, in due time, all indoor and outdoor areas for storage and installation at Site.

Transportation from the Manufacturer's factory to Naka Site shall be initiated after confirmation by JAEA of the availability of the above mentioned areas.

At the arrival at Naka site, visual inspection, including shock recorder/acceleration sensors, shall be repeated at presence of representatives of the Manufacturer and both IAs. An official note of the inspection shall be prepared and approved by representatives. Delivery on Site shall be regarded as completed when all components included in the present PA will be successfully delivered to Naka Site following the above indicated procedure.

After transportation from possible temporary storage areas to final installation room, that is under JAEA responsibility, handling at Naka Site is under F4E responsibility. JAEA shall be responsible to make available, in due time, all indoor and outdoor areas for storage and installation at Site.

8. DOCUMENTATION TO BE SUPPLIED

The final documentation shall include all the documentation described below, corresponding to the as built configuration of the component and including all the revisions performed during the installation and tests.

The documentation shall be provided in standard formats (Word, Excel, pdf, AUTOCAD) and shall be delivered both in electronic and hard-copy version.

8.1. Design Reports

Two Design Reports will be provided.

8.1.1. First Design Report

This document will be issued at the end of the DDP and it will demonstrate the full compliance with the Technical Specification. In particular it will include the following items:

- Detailed design description of the power section and the selection of rating and type of the major components.
- Seismic analysis for crowbar units and related auxiliaries.
- Layout drawings shall be provided showing the location of the various cubicles of each PFC/TF/FPPC PS unit.
- Block and functional scheme of the Control and Protection system.
Analysis of the PFC/ FPPC PS unit operation in both normal and fault conditions.
- Preliminary Site installation plan.

8.1.2. Transformers Design Report

This document will be issued at the end of the DDP and it will demonstrate the full compliance with the Technical Specification. In particular it will include the following items:

- Detailed design description of each type of converter transformers.
- Layout drawings shall be provided showing the location of each type of transformers inside the dedicated bay.
- Control and Protection apparatus of each type of transformers.
- Preliminary Site installation plan.

8.1.3. Final Design Report

The Manufacturer shall issue a Final Design Report after the Final Acceptance Tests on Site. The Manufacturer shall review all documents, information and drawings provided during the procurement. The final Design Report will be an updating of the first Design Report.

8.2. Detailed Testing Plan

A Detailed Testing Plan, including procedure and related time schedule shall be made available by F4E and agreed with JAEA at least two months before the starting of testing. This plan shall include:

- Factory Tests (ref. section 5.2.1 and 5.2.2) and Final Acceptance Tests on Site (ref. section 5.3) for each type of PS unit. For each test reference standard and acceptance criteria shall be defined. For factory tests, description of the available test facility shall also be included. The Manufacturer shall indicate which tests cannot be performed at his premises and shall propose alternative arrangements for their execution.
- Factory Tests (ref. section 5.2.3) and Final Acceptance Tests on Site (ref. section 5.3) for each type of transformer. For each test reference standard and acceptance criteria shall be defined. For factory tests, description of the available test facility shall also be included. The Manufacturer shall indicate which tests cannot be performed at his premises and shall propose alternative arrangements for their execution.

8.3. Tests reports

The Manufacturer shall provide written records of all Factory Tests and Final Acceptance Tests on Site performed. The Test Reports shall be provided not later than two month after the relevant tests have been performed. The Test Reports shall report clearly the results of the tests, which shall be compared with the requirements given in the Technical Specifications.

8.4. Operation and Maintenance Manual

The Manufacturer shall provide an Operation and Maintenance Manual including, but not limited to:

- Operation procedures
- Maintenance instructions, including calibration and adjustment procedures
- Check in case of fault indication

The final version of the Manual shall be provided no later than one month after completion of the Site tests.

8.5. Source codes

The source code of any software used for PLC, microprocessor, PLD or other programmable device shall be provided, no later than 6 weeks after acceptance of the system, together with sufficient documentation and software tools to modify the operation of the programmable devices.

8.6. Final Report

F4E shall issue a Final Report after the Final Acceptance Tests on Site. The Final Report shall include all the related documents, information and drawings provided during the present PA.

9. TRAINING

The Manufacturer shall provide training for the operating staff, in the operation, maintenance and troubleshooting of the supply.

Training shall be in four forms:

- preparation of an "Operation and Maintenance Manual" in such a way that technical staff on-site may get a good understanding of the equipment, its mode of operation and of the procedures to carry out setting and checks of protections, controls loops, maintenance interventions, etc;
- informal instruction during the execution of the Contract, especially during testing at the Manufacturer's Facilities and Site testing and commissioning. When Representatives of F4E/JAEA are present they will be allowed to ask a reasonable number of questions and/or seek clarifications without unduly delaying the activities of the Manufacturer;
- a formal presentation (in English) to the Site's technical staff lasting up to 10 days. The Manufacturer shall give the presentation, unless differently agreed with JAEA;
- instructions in the use of programmers and source code for any programmable devices.

10. NAKA SITE CONDITIONS

10.1. Ambient conditions

The equipments shall be installed in Naka, Ibaraki, Japan, at the JAEA Site. The magnetic field in these areas, related to the JT-60SA operation, will be less than 5 mT.

The ambient site conditions of the Naka site are summarized in Table 2.7-13 of PID.

During all phases of the installation and the commissioning the Manufacturer shall be responsible of the proper management of the component depending of the ambient condition reported in Table 2.7-13 of PID.

10.2. Seismic event

Some information about seismic events are given in section 1.8.3 of the PID. Seismic resistant design (ref. IEC68-3-3) is required for equipments with safety function in JT-60SA. Among PS units, only Quench Protection Units(QPC) and Crowbar (CB) units, and related equipments, are considered to have safety functions. For them the following In "Floor Accelerations" have to be taken into account for class B:

- Floor Acceleration_{Horizontal} = 4.5m/s² (=0.45G)
- Floor Acceleration_{Vertical} = 2.25m/s² (=0.225G)

It is calculated as the product of the following three parameters: "Ground acceleration (*ag*)" "Superelevation factor (*K*)" "Direction factor (*D*)", which in Naka Site are:

- Ground acceleration = 3 m/s²
- Superelevation factor *K* = 1.5
- Direction factor *D* x,y = 1.0, Direction factor *D*z : 0.5

As for specific requirements for the apparatus, there is the following classification:

- A class: Facilities involving radioactive substances.
- B class: Facilities connected to class A, or prevention apparatus for diffusion of radioactive substances
- C class: Facilities not classified to A nor B, and acceptable to conventional industrial safety level.

PS shall be manufactured based on class C standard; this means that they shall not be designed following particular guideline for seismic resistant design for power supply equipments, but, in any case, the mechanical switches, disconnectors, connections and so on should be able to maintain their position and to carry on their work.

10.3. The low voltage distribution system

The main data of the auxiliary power systems provided by JAEA at the connection point with the Power Supply equipments are summarized in Table 10.3-1.

Table 10.3-1 – Parameter of the JT-60SA low voltage distribution system at the connection point with the PS

	400 V ac	400 V ac UPS	100V dc UPS
Nominal voltage	200/400 V 3-ph, 4-w	200/400 V 3-ph, 4-w	100 V
Limits of the voltage variations	±10%	±5%	±5%
Nominal frequency	50 Hz, ±0.1%	50 Hz, ±0.1%	
Total harmonic distortion		< 5 %	

10.4. Grounding network

JAEA will provide two different networks for grounding and earthing.

10.5. Facilities in the PS buildings

10.5.1. Site water cooling systems

The JAEA cooling system shall provide two circuits, one for demineralised water dedicated to Aluminium components and a second one for the rough water.

In Tables 2.7-14 and 2.7-15 of PID are reported the main characteristic of the JT-60SA water cooling systems.

10.5.2. Air conditioning system

JAEA will provide air ventilation for the PS rooms; the parameters of the air ventilation system are summarized in Table 2.7-13 of PID for each room where the PSs shall be installed.

Without considering the PS operation, the air ventilation system is designed to guarantee the maximum indoor temperature and indoor humidity indicated in Table 2.7-13 of PID. These values have to be intended as averaged in all the room volume.

The ventilation is provided by ducts and openings

10.5.3. Compressed air system

On JT-60SA buildings, JAEA will distribute compressed air without major impurities, dry and lubricated. The compressed air distribution system has the characteristics shown in Table 10.5.3-1.

Table 10.5.3-1 – Parameters of the JT-60SA compressed air distribution system

Pressure	1.5 MPa ± TBD MPa
Available flow rate @min pressure	TBD m ³ /s

11. QUALITY ASSURANCE DOCUMENTS

The Quality Assurance provisions are regulated by

- the “Management Specification”; Annex A of the Procurement Arrangement
- the “JT-60SA Integrated Project Team Common Quality Management System” (ref. 2)
- the “JT-60SA EU Home Team Quality Management System” (ref.4)