



Agenzia nazionale per le nuove tecnologie,
l'energia e lo sviluppo economico sostenibile



MINISTERO DELLO SVILUPPO ECONOMICO



Ricerca di Sistema elettrico

ALFRED-SGBT. Preliminary Characterization by the HERO Test Section

A. Del Nevo, M. Tarantino, D. Rozzia, N. Forgiione, L. Scaletti



Report RdS/PAR2013/040

ALFRED-SGBT. Preliminary Characterization by the HERO Test Section

A. Del Nevo, M. Tarantino - ENEA, D. Rozzia, N. Forgione, L. Scaletti - CIRTEN UNIPI

Settembre 2014

Report Ricerca di Sistema Elettrico

Accordo di Programma Ministero dello Sviluppo Economico - ENEA

Piano Annuale di Realizzazione 2013

Area: Produzione di energia elettrica e protezione dell'ambiente

Progetto: Sviluppo competenze scientifiche nel campo della sicurezza nucleare e collaborazione ai programmi internazionali per il nucleare di IV Generazione

Obiettivo: Sviluppo competenze scientifiche nel campo della sicurezza nucleare

Responsabile del Progetto: Mariano Tarantino, ENEA

Il presente documento descrive le attività di ricerca svolte all'interno dell'Accordo di collaborazione "Sviluppo competenze scientifiche nel campo della sicurezza e collaborazione ai programmi internazionali per il nucleare di IV generazione"

Responsabile scientifico ENEA: Mariano Tarantino

Responsabile scientifico CIRTEN: Giuseppe Forasassi

Titolo:
ALFRED-SGBT. Preliminary characterization by the HERO test section
Descrittori

Tipologia del documento: Rapporto Tecnico
Collocazione contrattuale: Accordo di programma ENEA-MSE su sicurezza nucleare e reattori di IV generazione
Argomenti trattati: Generation IV Reactors
 Tecnologia dei metalli liquidi
 Termoidraulica dei reattori Nucleari

Sommario

Il presente rapporto documenta la fase di montaggio strumentazione e analisi preliminare mediante codice termoidraulico di sistema (RELAP-5.3) della sezione di prova Heavy liquid metal – pressurized water cooled tube (HERO). Essa consiste in un bundle in scatola esagonale di 7 tubi a doppia parete a baionetta rappresentativi del generatore di vapore del reattore ALFRED. La sezione di prova verrà montata su CIRCE ed è concepita per essere uno strumento di supporto allo sviluppo del generatore di vapore di ALFRED e alla validazione di codici principalmente di tipo termoidraulico di sistema grazie ad una accurata selezione della strumentazione.

Note
AUTORI

Del Nevo A., Tarantino M. (ENEA)

Rozzia D., Forgiione N., Scaletti L (UNIPI)

Copia n.
In carico a:

REV.	DESCRIZIONE	DATA	NOME	REDAZIONE	CONVALIDA	APPROVAZIONE
2			NOME			
			FIRMA			
1			NOME			
			FIRMA			
0	EMMISSIONE	29/09/14	NOME	M. Tarantino	I. Di Piazza	M. Tarantino
			FIRMA			



CONTENTS

1	INTRODUCTION.....	5
2	DESIGN CONSTRUCTION AND ASSESSMENT OF HERO SGBT UNIT.....	9
2.1	Bayonet tube design	9
2.1.1	Material selection.....	9
2.1.2	Determination of the tube geometry	11
2.1.3	Feedback from the SGBT construction and from the TxP campaigns	13
2.1.4	Bayonet Tube SG construction	14
2.1.5	Bayonet Tube SG instrumentation.....	22
2.2	Modeling of the Bayonet Tube SG unit by RELAP-5.....	29
3	CONCLUSIONS.....	37
	REFERENCES	38
	APPENDIX A: HERO SG BAYONET TUBE UNIT MAIN COMPONENTS	39



1 Introduction

The Heavy liquid metal – pressurized water cooled tube (HERO) aims to study a 1:1 bayonet tube/s under conditions that represent, as much as possible, the operation of the ALFRED SG. The facility is expected to be a suitable tool to support the validation process of TH-Sy codes and CFD codes coupled simulations. Two different conceptual configurations have been assessed to check their feasibility and then, the most promising solution has been designed and constructed.

The first one, deals with a standalone facility to test a single tube and is based on natural circulation into the lead side ^[1]. The remaining, deals with a test section to be introduced in CIRCE to investigate an hexagonal bundle of seven tubes and is based on gas enhanced circulation into the lead side ^[2]. This last configuration has been selected, designed, constructed (the SG bundle) and the test section is under commissioning.

CIRCE basically consists of a cylindrical vessel (Main Vessel S100) filled with about 70 tons of molten Lead-Bismuth Eutectic (LBE) with argon cover gas and recirculation system, LBE heating and cooling system, several test sections welded to and hung from bolted vessel heads for separate-effect and integral testing, and auxiliary equipment for eutectic gas enhanced circulation ^[3].

In *Fig. 1*, an isometric view of the facility is shown. The facility can be considered made up of two parts, the first being dedicated to the LBE containment and management, and the other consisting of the auxiliary systems.

Concerning the first part, the main components are the above mentioned vessel S100, the storage tank S200 and the intermediate vessel S300; this latter one being used during the handling of the LBE between the two other vessels. During the loading operations, the LBE is gradually transferred from the storage tank to the S300 vessel. In this way, step by step, S100 is gradually filled from the bottom. This main vessel consists of a vertical vessel which is 8500mm in height, connected by gates to the other systems, from both the LBE and gas sides. It is equipped with electrical heating cables, installed on its bottom and lateral surface. This heating system allows operating in a temperature range of 200÷400 °C. The main vessel is also equipped by a skimming line and a passive pressure safety system, in order to guarantee the LBE top level and to prevent accidental overpressure. The main parameters of CIRCE are listed in *Tab. 1*.

The configuration of HERO is based on a hexagonal shroud that contains seven SGBT of same geometry of the ALFRED SG *Fig. 2*. This device is placed inside CIRCE and is fed by LBE which flows by gas enhanced circulation from the top by means of fissures that communicate with the CIRCE pool. The LBE flows inside the tube bundle for six meters (as in the SG of ALFRED) and then it leaves the device from the bottom which is opened. Thermal insulation of the shroud from CIRCE is required.

This system does not pose problems that could impair its feasibility. Furthermore, it has the following advantages compared to the standalone facility described in Ref. [1]:

- The SGBT design of ALFRED could be reproduced as much as technological limits or market limits will impair its construction (i.e. F/M steel T91 could not be used as tube material due to welding problems and the difficulty to acquire it only for seven tubes).
- Seven tubes are more representative of the SG than one tube and they allow the experimental assessment of dynamic instabilities.

- The lead mass flow is regulated by enhanced circulation using a system that is already available in CIRCE.
- The required power (443 kW) is supplied by a system that is already available in CIRCE.
- The cost of the test section is lower than those of a standalone facility.

Parameters	Value
Outside diameter [mm]	1200
Wall thickness [mm]	15
Material	AISI 316L
Max LBE Inventory [kg]	90000
Electrical Heating [kW]	47
Cooling Air Flow Rate [Nm ³ /s]	3
Temperature Range [°C]	200 to 500
Operating Pressure [kPa]	15 (gauge)
Design Pressure [kPa]	450 (gauge)
Argon Flow Rate [Nl/s]	15
Argon Injection Pressure [kPa]	600 (gauge)

Tab. 1 – CIRCE main data.

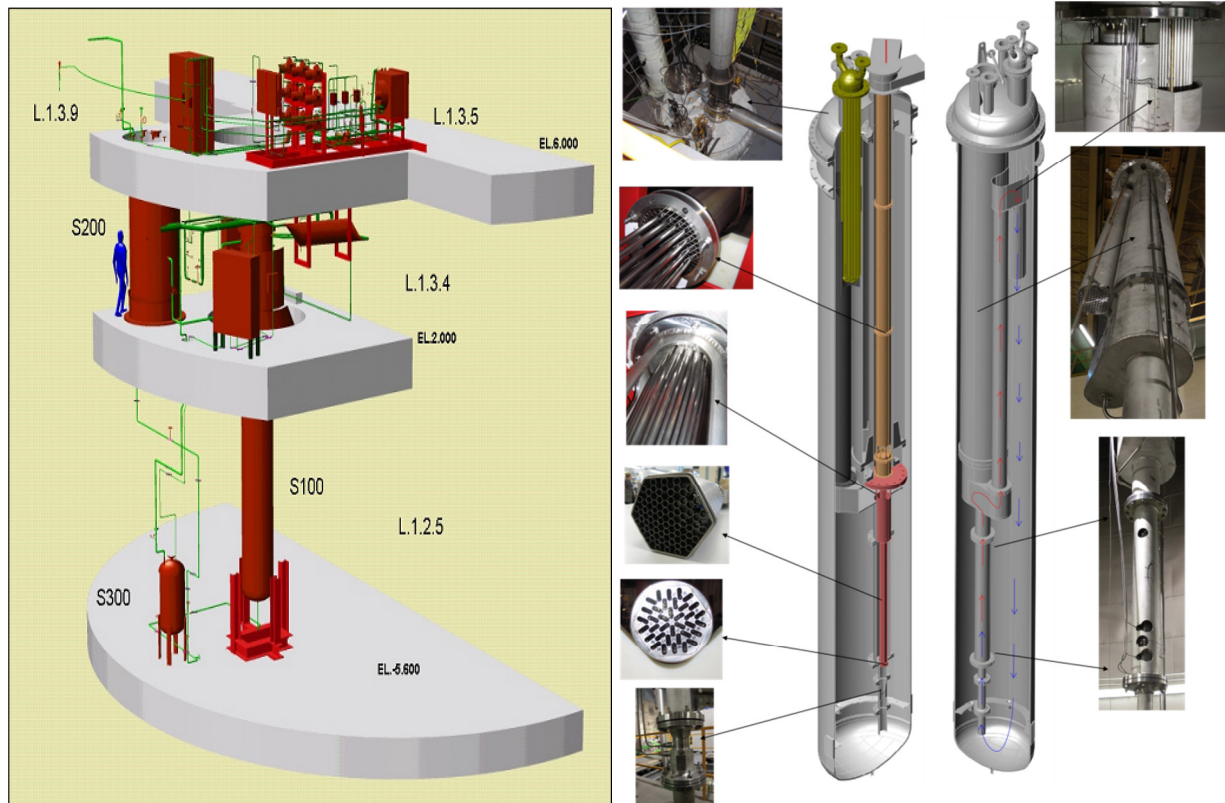
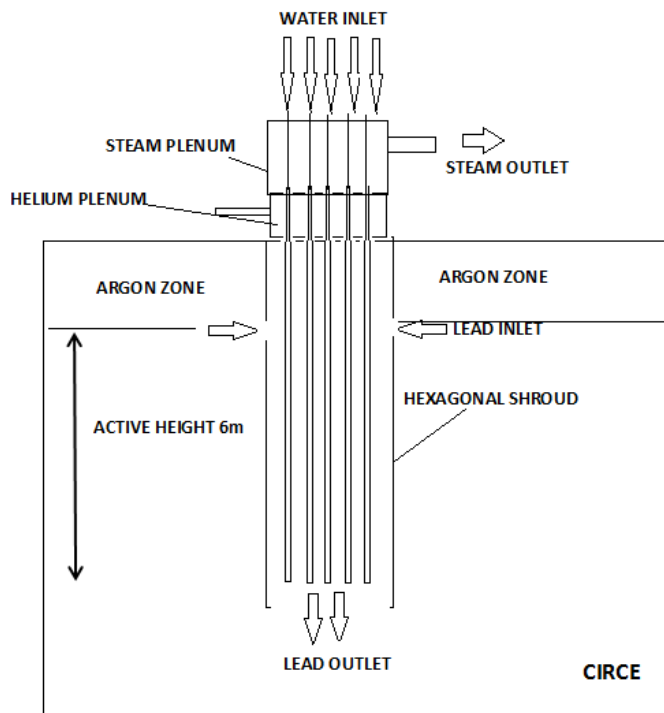
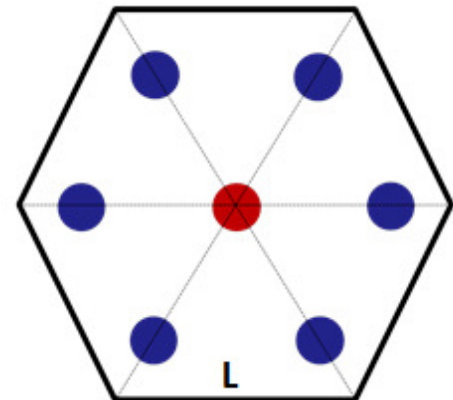

Fig. 1 – CIRCE isometric view.



Schematic layout



Transversal section of the SG

Shroud geometry		
L	m	0.0726
Transversal area	m ²	0.0137
Power	kW	504

Fig. 2 – HERO test section, conceptual scheme of the SG unit.



2 Design construction and assessment of HERO SGBT unit

2.1 Bayonet tube design

2.1.1 Material selection

In order to construct the bayonet tubes it was necessary to modify some of the materials adopted for the ALFRED SG and to define the materials still not identified. These design choices are given in *Tab. 2*. In order to assess the relative influence of the materials on the ALFRED design (here indicated as reference design), four distinct calculations have been executed by means of RELAP-5 version 3.3 [4][5][6]:

- **SiC:** the high conductivity material used to fill the annular region between the lead and the water-steam sides was not yet defined by ANSALDO. The reference analysis was conducted assuming sintetic diamond. Due to the cost of this material Silicon Carbide was assumed as alternative powder. The conductivity of this material has been modeled in the powder gap thermal structure instead of sintetic diamond. As in the reference calculation, it is assumed .3 porosity Si-C and its conductivity has been selected on the basis of correlations Case 1 (Eq. 1) and Case 2 (Eq. 2). Since Si-C has lower conductivity than sintetic diamond, it is expected a degradation of the TH performance.
- **AISI:** The conductivity of AISI-304 has been modeled in the thermal structures of the tubes instead of T91. This choice is justified by the un-availability of small lots of T91 and by the complexity to realize and qualify T91 welded joints. Since T91 has higher conductivity and higher mechanical resistance than AISI-304, it is expected a degradation of the TH performance due to both lower conductivity and higher thicknesses.
- **FOAM:** ZIRCOFOAM 250 has been modeled in the feed-water tube thermal structure instead of insulating paint RHY-12. Its conductivity is given in *Tab. 3*. ZIRCOFOAM 250 has similar properties compared to RHY-12. The choice of this material is justified by its availability (RHY-12 is fabricated by a Chinese society while ZIRCOFOAM is fabricated by an Italian society). It is expected to have minor influence on the tube performance.
- **SiC + AISI + FOAM:** this analysis assumes all the hypothesis reported above.

The steam outlet temperature has been selected as figure of merit to assess the tube performance. *Fig. 3* and *Fig. 4* report the steam temperature along the annular riser ascending region for case1 and case2, respectively. The following conclusions can be drawn:

- ZIRCOFOAM-250 has negligible influence on the SGBT performance.
- The use of AISI-304 decreases the outlet temperature of about 15 °C.
- The use of SiC decreases the outlet temperature from 7 to 15 °C depending on the correlation adopted.
- SiC + AISI + FOAM highlight a global decrease of the outlet temperature from 20 to 30 °C depending on the correlation adopted to model the powder. Case1 predicts an outlet temperature of 435°C while the case2 predicts 409°C. Both these values are acceptable for a mock-up prototype.

$$k_{\text{powder}} = k_s^{(1-\varphi)} \cdot k_f^\varphi \quad \text{Eq. 1}$$

$$\frac{k_{\text{powder}}}{k_f} = [\lambda]^{(0.208-0.757\ln\varphi-0.057\ln\lambda)} \quad \text{Eq. 2}$$

Where $g \lambda = (k_s / k_f)$, k_s is the conductivity of the solid, k_f is those of the fluid and φ is the porosity

Component	ANSALDO	Reference case	HERO-SGBT
Annular gap powder	55 time the conductivity of He	Sintetic diamond	Silicon Carbide
Insulating material	RHY-12 paint	RHY-12 paint	ZIRCOFOAM-250
Tube	T91	T91	AISI-304

Tab. 2 – HERO-CIRCE SGBT unit: materials.

Temperature [K]	Thermal conductivity [W/mK]
423.15	0.060
523.15	0.071
673.15	0.088
873.15	0.113
1073.15	0.179

Tab. 3 – HERO-CIRCE SGBT unit vs. RELAP5, thermal conductivity of ZIRCOFOAM 250.

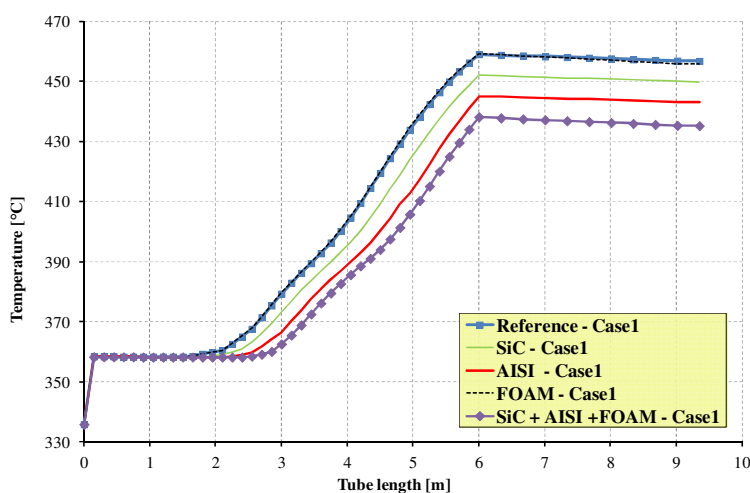

Fig. 3 – HERO-CIRCE SGBT unit vs. RELAP5 investigations on materials, steam temperature, case 1.

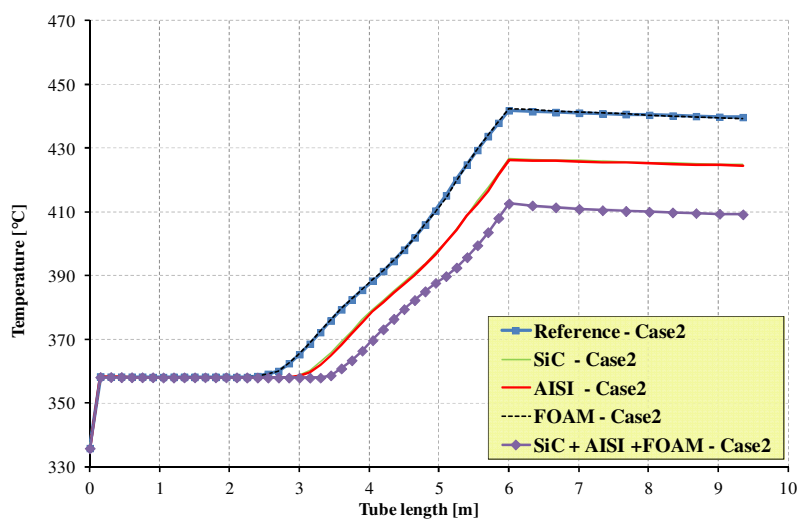

Fig. 4 – HERO-CIRCE SGBT unit vs. RELAP5 investigations on materials, steam temperature, case 2.

2.1.2 Determination of the tube geometry

In order to construct few prototypic tubes it was necessary to modify the geometry of the tubes because of two main reasons:

- The tube geometry adopted in the reference calculations does not agree to the standard ANSI/ASME B.36.19.
- The use of AISI-304 instead of T91 requires to increase the tube thickness because of the reduced mechanical properties.

Five configurations have been analysed, they are described in *Tab. 4* and *Tab. 6*. The operating conditions have not been modified (see *Tab. 5*). The steam temperature along the annular riser is depicted in *Fig. 5*, *Fig. 6*. RUN1 has been selected as up-dated configuration to be implemented in HERO. It allows to reach a steam temperature between 410°C and 427°C depending on the correlation adopted to model the powder.

Compared to the design of ANSALDO, this configuration has:

- Larger tube outermost diameter that means larger pitch (since P/D has been preserved),
- Larger thickness of the tubes (excepts the inner tube),
- Larger insulating gap width that enhances the insulation of the feed-water tube,
- Smaller annular riser gap that tends to increase the fluid velocity and therefore the distributed pressure drops,
- Smaller powder gap width that reduce the impact of the correlation adopted to model the powder on the TH tube performance.

The mechanical verifications substantially confirm the geometrical quantities selected by TH analysis even if, due to the reduced thickness of the inner tube, the SG bayonet tube unit could be licenced to operate at a maximum pressure of 174 bar instead of 180 bar. Based on this calculations, the construction of the unit was assigned to CRIOTEC ^[2].

#	Description	REF.	RUN1	RUN2	RUN3	RUN4	RUN5
1	Slave tube outer diameter [mm]	9.52	9.53	9.53	9.53	9.53	9.53
2	Inner tube outer diameter [mm]	19.05	19.05	19.05	19.05	17.15	25.40
3	Second tube outer diameter [mm]	25.40	25.40	26.67	26.67	25.40	33.40
4	Third tube outer diameter [mm]	31.73	33.40	33.40	33.40	33.40	42.16
5	Powder annular gap width [mm]	1.07	0.62	1.72	0.59	0.62	0.82
6	Water steam gap [mm]	1.30	1.07	0.94	0.94	2.06	0.71
7	Paint gap	2.89	3.11	3.11	3.11	2.16	6.29
8	Slave tube thickness [mm]	1.07	1.22	1.22	1.22	1.22	1.22
9	Inner tube thickness [mm]	1.88	1.65	1.65	1.65	1.65	1.65
10	Second tube thickness [mm]	1.88	2.11	2.87	2.87	2.87	3.38
11	Third tube thickness [mm]	2.11	3.38	1.65	2.77	2.77	3.56
12	P/D	1.42	1.42	1.42	1.42	1.42	1.42
13	P [mm]	45.1	47.4	47.4	47.4	47.4	59.9

Tab. 4 – HERO-CIRCE SGBT unit vs. RELAP5 v 3.3, modified geometries.

#	Operating conditions	REF.	RUN1	RUN2	RUN3	RUN4	RUN5
1	Feed-water inlet temperature [°C]	335	335	335	335	335	335
2	Feed-water mass flow [kg/s]	0.047	0.047	0.047	0.047	0.047	0.047
3	Steam outlet pressure [MPa]	18.0	18.0	18.0	18.0	18.0	18.0
4	Lead inlet temperature [°C]	480	480	480	480	480	480
5	Lead mass flow [kg/s]	6.367	6.367	6.367	6.367	6.367	6.367

Tab. 5 – HERO-CIRCE SGBT unit vs. RELAP5 v 3.3, operating conditions of one tube.

Component	Description	REF	RUN1	RUN2	RUN3	RUN4	RUN5
Feedwater tube	Water flow area [m ²]	4.278E-05	3.948E-05	3.948E-05	3.948E-05	3.948E-05	3.948E-05
	Hydraulic diameter [m]	0.00738	0.00709	0.00709	0.00709	0.00709	0.00709
	Left Dth [m]	0.00738	0.00709	0.00709	0.00709	0.00709	0.00709
	Right Dth [m]	0.00553	0.004498	0.00395	0.00395	0.00901	0.00254
Annular riser	Water-steam flow area [m ²]	8.277E-05	6.730E-05	5.903E-05	5.903E-05	0.00012	5.068E-05
	Hydraulic diameter [m]	0.00259	0.00213	0.00188	0.00188	0.00403	0.00124
	Left Dth [m]	0.00487	0.00405	0.003591	0.003591	0.00729	0.00242
	Right Dth [m]	0.03864	0.04093	0.04093	0.04093	0.04093	0.05110
Lead channel	Lead flow area [m ²]	0.00096	0.00107	0.00107	0.00107	0.00107	0.00172
	Hydraulic diameter [m]	0.03864	0.04093	0.04093	0.04093	0.04093	0.05110

Tab. 6 – HERO-CIRCE SGBT unit vs. RELAP5, main input deck modifications.

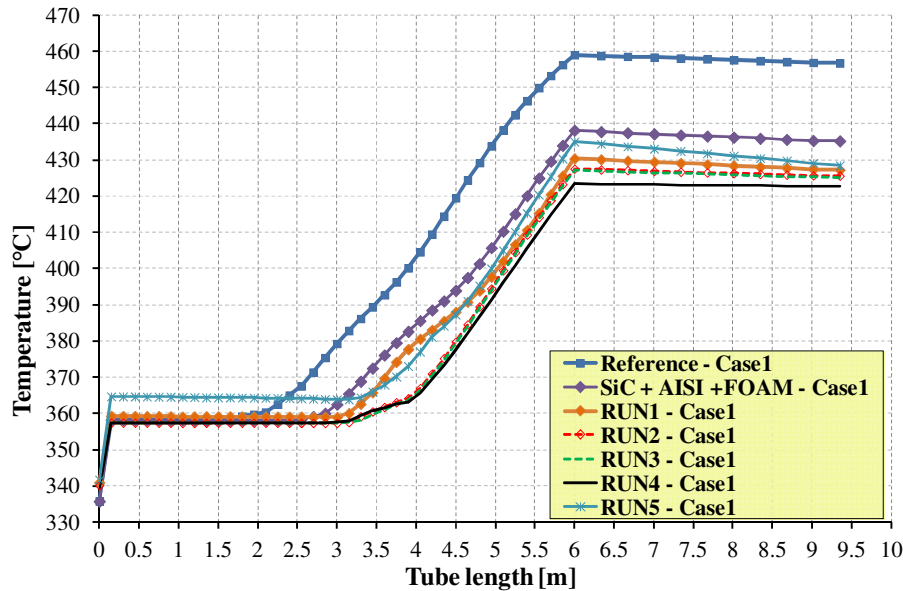

Fig. 5 – HERO-CIRCE SGBT unit vs. RELAP5, investigations on tube geometry, steam temperature, case 1.

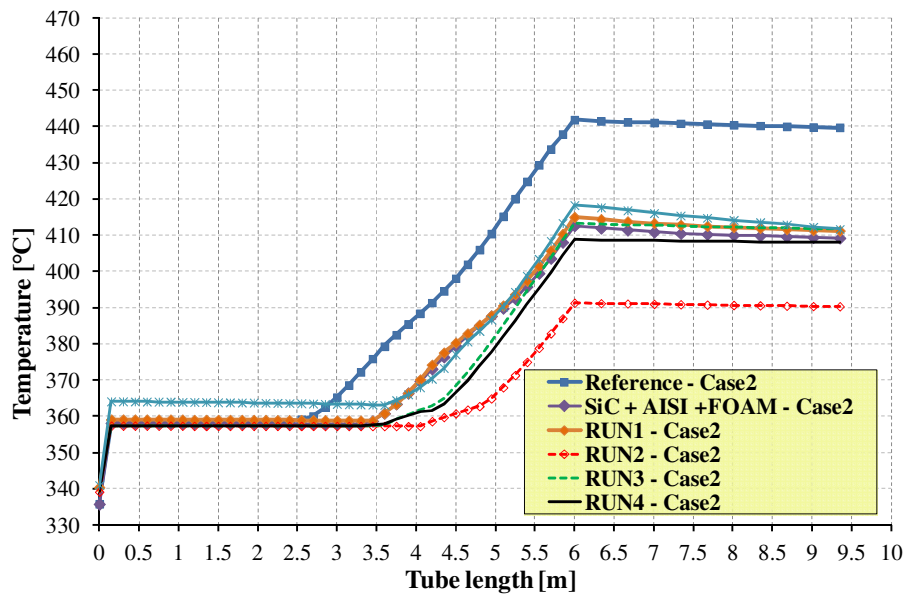

Fig. 6 – HERO-CIRCE SGBT unit vs. RELAP5 investigations on tube geometry, steam temperature, case 2.

2.1.3 Feedback from the SGBT construction and from the TxP campaigns

During the construction phase of the SG bayonet tube unit, two main feedback arise and required the modification of its design and the development of an up-dated design:

- The experimental campaigns experienced in the Tubes for Powder facility (TxP) on the Si-C powder acquired for the SG bayonet tube unit revealed an un-expected low conductivity of this material^[8]. Therefore, as a back-up solution, AISI-316 powder has been selected as heat enhancer medium instead of Si-C.
- The society that takes in charge the construction of the SG bayonet tube unit (CRIOTEC) performed some preliminary tests on ZIRCO-FOAM-250 insulating foam. This material revealed low adhesive properties when coated to the slave tube outer surface, Fig. 7. Therefore, in order to avoid the detachment of ZIRCO-FOAM-250 during the operation of the SG bayonet tube unit, and considering the experience of CRIOTEC in the realization of under vacuum components, dry air was introduced instead of ZIRCO-FOAM-250 and slight vacuum was then realized between the slave tube and the first tube.

Due to these modifications (and particularly the use of AISI-316 powder), the HERO test section is expected to produce superheated steam at a maximum temperature of about 400°C, Fig. 8. The calculation reported in this figure has been obtained based on the input deck described in section 2.1.2 assuming AISI-316 powder whose conductivity is according to those obtained in the TxP experimental campaigns^[8].



Fig. 7 – HERO-CIRCE SGBT unit, coating of ZIRCO-FOAM-250 on the slave tube outer surface.

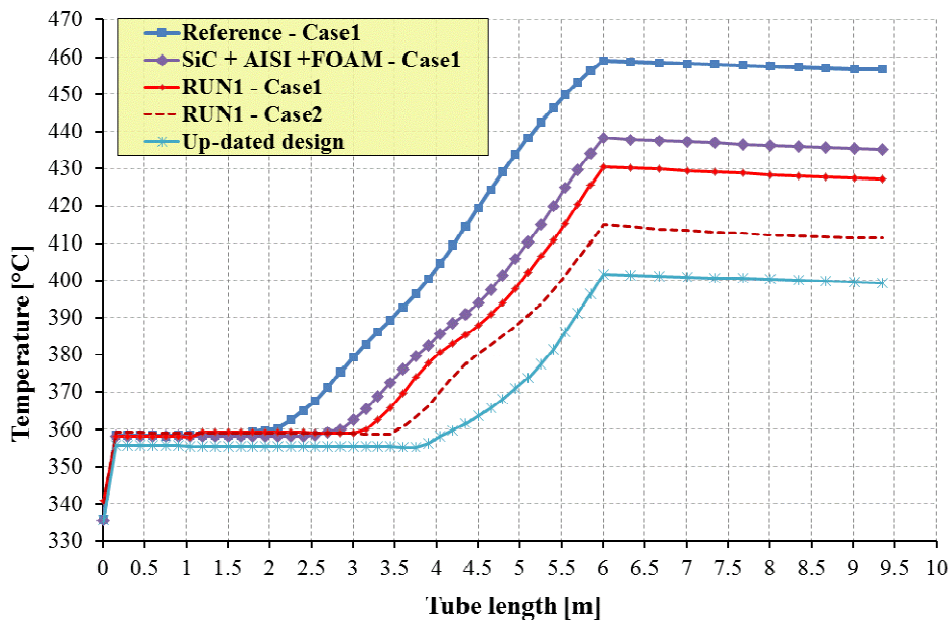

Fig. 8 – HERO-CIRCE SGBT unit vs RELAP-5 calculations: steam temperature along the annular riser.

2.1.4 Bayonet Tube SG construction

The construction of the device was assigned to CRIOTEC. The detailed constructive design is reported in Appendix A. The main operating parameters of the unit are summarized in *Tab. 7* and *Tab. 8*.

The bayonet tube bundle is given in *Fig. 9* and *Fig. 10*, it is composed of:

- A top flange with seven holes to accommodate the bayonet tubes (labeled as item 1 in *Fig. 9*) and one hole for the instrumentation. It connects the SG bayonet tube unit to the CIRCE S-100 component and sustains the helium chamber, the steam chamber, the bayonet tubes and the hexagonal shroud. This flange is $\Phi 356$ mm with a thickness of 30 mm and is made of AISI-304.
- Welded above the top flange (and therefore located outside CIRCE), there is the Helium chamber (item 2 in *Fig. 9*). It is constituted by a AISI-304 tube 6" sch.40 with an integral

- roof. The helium chamber have appropriate holes to accommodate the bayonet tubes. These have been fixed to the holes by sealing joints to guarantee no helium leakages up to 5 bars.
- On the top of the helium chamber there is the steam chamber that accommodates the superheated steam and contains the feed-water tubes (sealed by joints that are capable to sustain superheated steam at 172 bar). It is basically constituted by a tube with an integral roof (item 3 in *Fig. 9*).
 - The bayonet tube dimensions are reported in *Tab. 8*, its main length is about 7360mm being the active length equal to 6000mm.
 - In order to measure differential pressure drops in the feed-water tube and in the annular riser, the bottom ends of the tubes have been modified as reported in *Fig. 11*. Instead of hemispherical separated ends, they have been welded to a plate with a hole. This required the use of seven thermal compensators (item 18) to accommodate the differential elongation between the third and the second tube.
 - In order to experimentally investigate the 2 phase flow stability of the unit, a special device has been introduced at the feed-water tube inlet. It allows to install a removable orifice whose diameter can be changed simply substituting the Swagelok. It is designed with the possibility to measure the pressure drop of the feed-water across the orifice, *Fig. 12*.
 - The bayonet tubes are kept in position by means of five hexagonal spacer grids whose design is reported in *Fig. 13*.

The SGBT unit (*Fig. 14*) is contained into a double wall wrap depicted in *Fig. 15*. It has been constructed by LIMAINOX and it consists of:

- An hexagonal wrap with spacers (to keep a given meatus between the wrap and the external shroud), which is 6795mm in length and whose inner and outer transversal heights are, respectively, 126mm and 132mm. Six fissures 180mm x 40mm are realized in the wrap at the top of the active length. The fissures are designed to be placed inside the cylindrical distributor of CIRCE being totally submerged by the LBE that feed the SGBT unit.
- A cylindrical external shroud that is located below the fissures and which is concentric to the hexagonal wrap. It is sealed at the bottom and at the top in order to provide a meatus which is filled by air to avoid heat exchange between the pool of CIRCE and the SGBT unit. The external shroud includes a thermal compensator to accommodate the differential elongation between the shroud and the hexagonal wrap.
- A cylinder hexagon adaptor tube which is welded at the top of the hexagon by means of a disc. The cylinder upper end has four buttonholes each of them consisting in a drilled plate welded to the cylinder to fix the wrap at the CIRCE top flange (S-100) inner surface. In order to keep in communication the argon inside the wrap with those inside the external pool, the adaptor has a transversal fissure at its top. This fissure also acts as exit for the cables of the thermocouples located in the lead side, inside the wrap.

Description	Unit	Steam line	Helium line	LBE side
Fluid	--	Water - steam	Helium	LBE
Circulation mechanism	--	Axial pump + accumulator	Storage tank for leakage refilling	Gas enhanced
Main components	--	7 bayonet tubes, steam chamber	Helium chamber	SGBT unit shell
Bundle type and P/D	-	Triangular	--	Shell
Operating inlet temperature	°C	335	--	480
Operating mass flow	kg/s	0.330785	stagnant	44.573529
Design pressure	bar	172	5.0	As CIRCE
Operating pressure	bar	170	4.5	Hydraulic head
Hydraulic head in design condition	bar	0.7	--	--
Hydraulic head in test condition	bar	0.7	--	--
Test pressure	bar	180	--	--
Design temperature	°C	432	432	As CIRCE
Volume	m ³	0.0083	0.0054	--
Empty weight	kg	135	--	--
Code	--	EN13445	--	--
Welding joint efficiency	--	1	--	--
Notified body	--	TUV0948	--	--
Welding specification	--	WKF/3479/1	--	--
Serial number	--	13173	--	--
CE - PED	--	III Category	B1+F Module	--

Tab. 7 – HERO-CIRCE SGBT unit, main data.

Label	Inner diameter [mm]	Outer diameter [mm]	Thickness [mm]	Material
Feed-water slave tube	7.09	9.53	1.22	AISI-304
Feed-water tube gap	9.53	15.75	3.11	Slight vacuum
Feed-water outer tube	15.75	19.05	1.65	AISI-304
Annular riser gap	19.05	21.18	1.07	Water-steam
Second tube	21.18	25.40	2.11	AISI-304
Annular gap	25.40	26.64	0.62	AISI 316 powder
Third tube	26.64	33.40	3.38	AISI-304

Tab. 8 – HERO-CIRCE SGBT unit, tube design

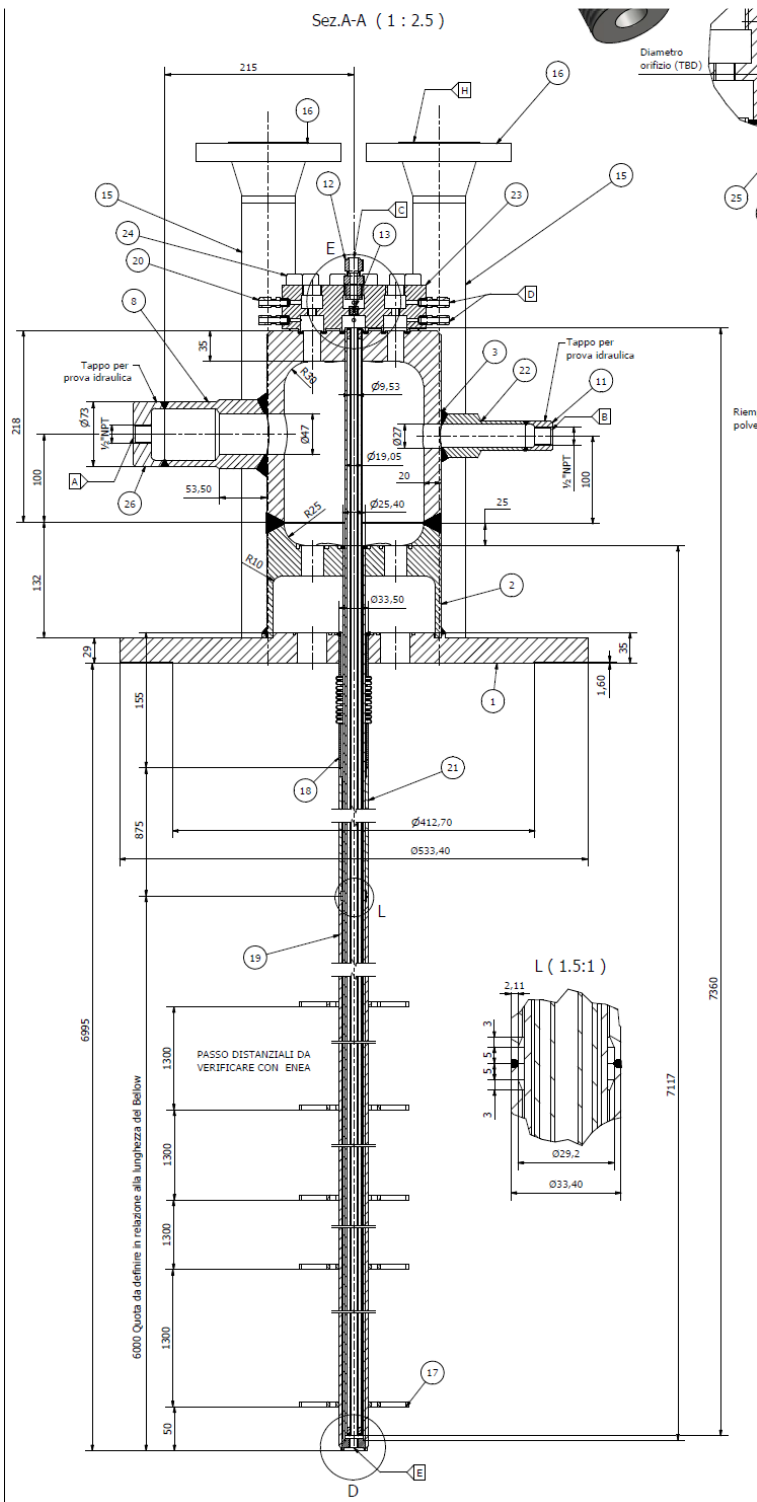

Position	N°	Description
1	1	Flange to S-100
2	1	Helium chamber
3	1	Steam chamber
4	7	Second tube Φ25.4mm s 2.11mm
5	7	Inner tube Φ19.05mm s 1.65mm
6	7	Slave tube Φ9.53mm s 1.22mm
7	14	Ring spacer
8	1	Steam outlet
9	2	Swagelok SS- 6MO-1-2W
10	1	Thermocouple outlet
11	2	Threaded plug case
12	7	Swagelok SS- 10MO-1-8
13	7	Orifice 1/8 "
14	7	End cap 25.4mm
15	3	Oxygen sensor tube
16	3	Flange
17	5	Grid spacer
18	7	Thermal stress accommodator
19	7	Third tube Φ33.4mm s 3.38mm
20	14	Swagelok SS- 6MO-1-2
21	1	Third tube Φ33.4mm 1000mm
22	1	Steam thermocouples casing
23	1	Water flange
24	12	UNI 5931 M12 x 70
25	7	Seal
26	1	Plug

Fig. 9 – HERO-CIRCE SGBT unit: main overview.



Fig. 10 – HERO-CIRCE SGBT unit: bundle arrangement.

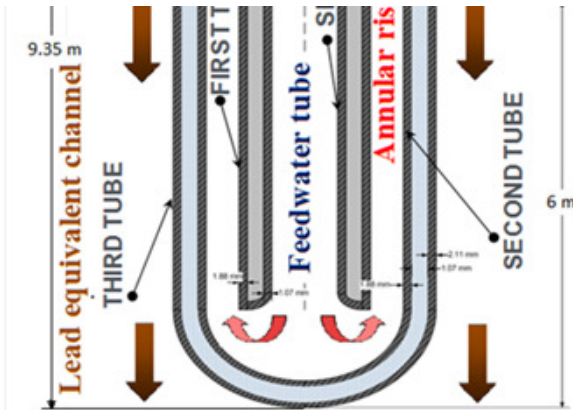

a) ALFRED

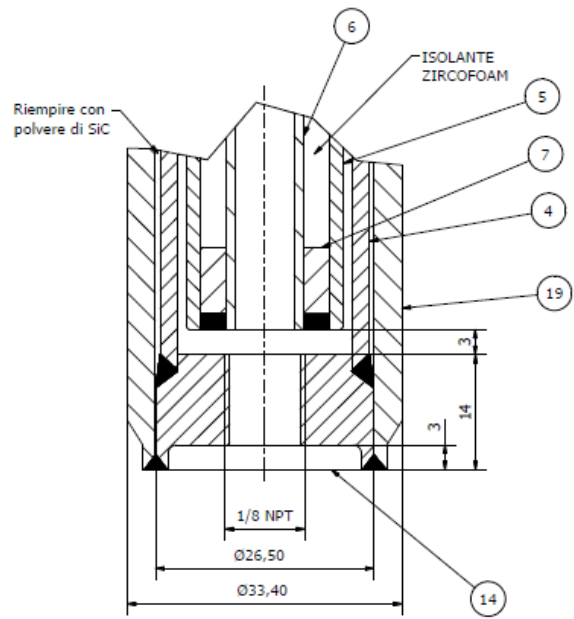

Vista D (2,5 : 1) Terminale tubi

b) HERO test section



d) HERO test section, bayonet tubes ends



d) HERO test section, thermal compensators

Fig. 11 – HERO-CIRCE SGBT unit: bayonet tube bottom ends.

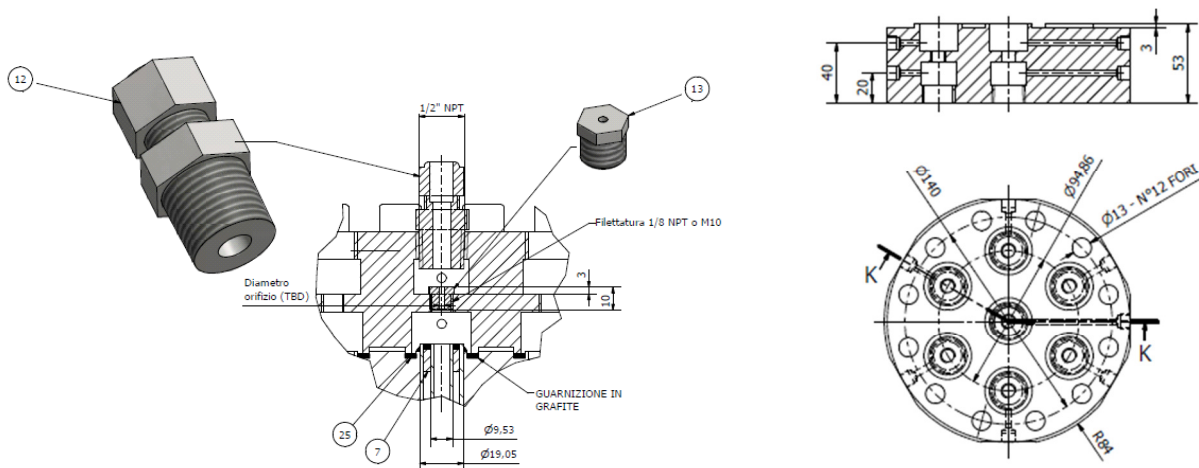

Fig. 12 – HERO-CIRCE SGBT unit: feed-water tube inlet.

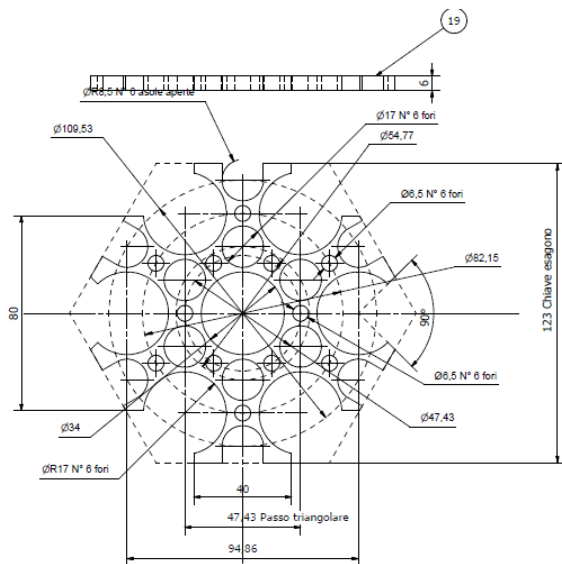

Fig. 13 – HERO-CIRCE SGBT unit: spacer grid.

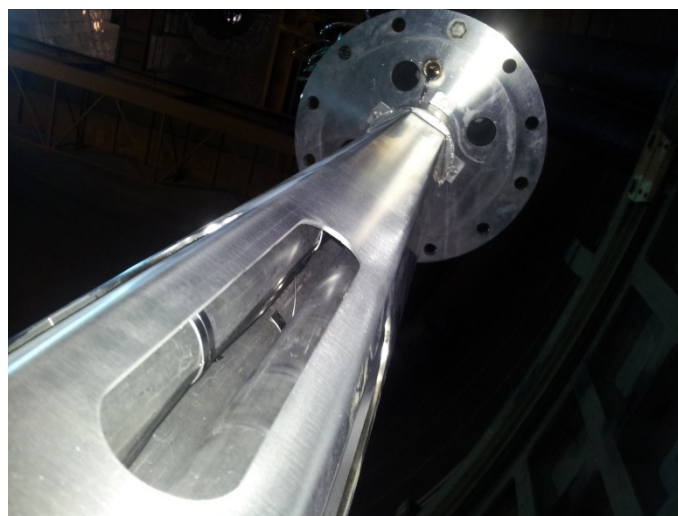

Fig. 14 – HERO-CIRCE SGBT unit: bayonet tubes inserted inside the wrap.

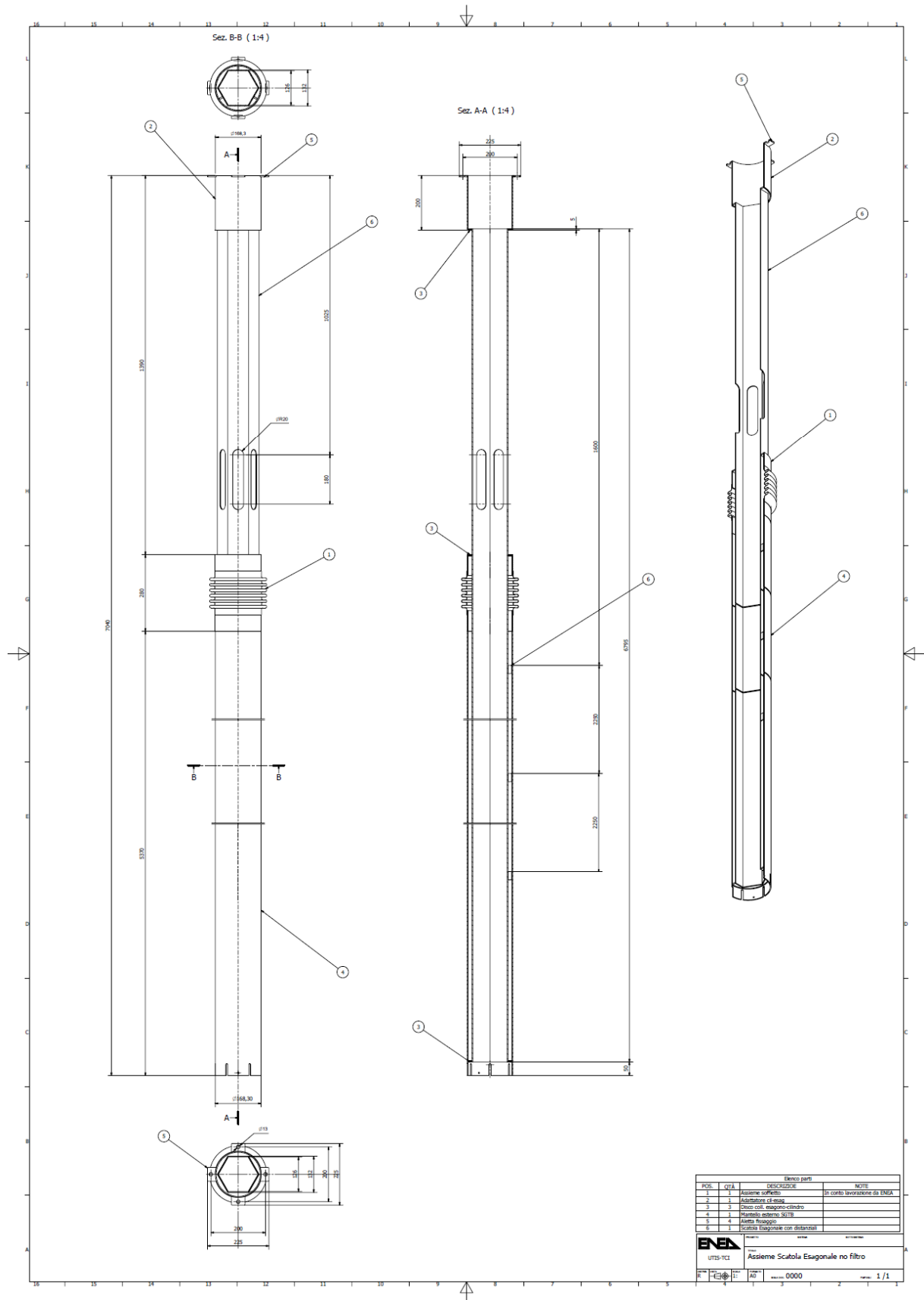



Fig. 15 – HERO-CIRCE SGBT unit: hexagonal wrap.

 Ricerca Sistema Elettrico	Sigla di identificazione	Rev.	Distrib.	Pag.	
	ADPFISS – LP2 – 072	0	L	22 di	45

2.1.5 Bayonet Tube SG instrumentation

The SGBT unit is instrumented with 65 thermocouples (TCs), 21 differential pressure transducers, 2 absolute pressure transducers and 8 flow meters, *Tab. 9*.

The central tube (labeled as tube 0) is instrumented with 31 thermocouples, *Fig. 16*:

- The water-steam path is monitored by four TCs whose diameter is 0.5mm. They are placed in the center of the bulk. The first is at feed-water tube inlet, the second is at the feed-water tube end, the third is at annular riser active length end and the last one is closed to the steam plenum.
- Ten TCs (Φ 0.5mm) are placed in the annular riser active length (starting from 1500mm to the bottom with a distance of 300mm), at the center of the bulk in order to monitor the boiling length.
- One TC (Φ 0.5mm) is placed at the feed-water tube inlet on its outer surface in order to capture condensation phenomena that may in principle take place above the active length because of the heat exchange between the superheated steam that is leaving the unit and the feed-water that is entering it.
- Four TCs (Φ 0.5mm) are located inside the powder gap at four representative axial elevations (1500mm, 3000mm, 4200mm and 6000mm). These TCs were not installed because they break during their assembling.
- Twelve TCs (Φ 1mm) are located at the third tube outer wall surface (LBE side) at four axial elevations (1500mm, 3000mm, 4200mm and 6000mm) and three azimuthal positions (0, 120°, 240°). The first three elevations are combined with other TCs located inside the wrap to monitor the equivalent sub-channels while the last elevation (6000mm) will provide a characterization of the LBE temperature profile at its inlet level (fissures level).

The remaining tubes (labeled as tube 1 to 6) are instrumented with 18 TCs, *Fig. 17*:

- Two TCs (Φ 0.5mm) are placed in each tube one at its inlet (feed-water tube bulk) and the other at its outlet (annular riser bulk).
- The remaining six TCs (Φ 1mm) are placed at three axial elevations (1500mm, 3000mm, 4200mm) in the outer side (LBE side) of two tubes: tube 1 and tube 2.

The equivalent LBE sub-channel bounded by tube 0, tube 1 and tube 2 is monitored at its periphery at three axial elevations by the TCs located at the outer surface of these tubes and at its center by means of three TCs, *Fig. 18* (one at each elevation, Φ 1mm). Three boundary sub-channels bounded by tubes 1-2, tubes 3-4, and tubes 5-6 are monitored by 3 center-bulk TCs at three axial elevations (totally 9 TCs Φ 1mm). Finally, four TCs (Φ 1mm) are located in the steam plenum. *Fig. 19* reports some details of the instrumentation.

The differential pressure transducers allow to measure, per each tube, the pressure drop across the orifice, the total pressure drop along the tube (feed-water tube and annular riser), the descended pressure drop (feed-water tube only) and the ascendant pressure drop (annular riser only). Absolute pressure is measured in the steam chamber and in the feed-water collector. The mass flow rate is measured at each bayonet tube inlet and at the feed-water collector inlet, *Fig. 20*.

The devices presently installed is indicated with Y after the number in the first column.

#	ID	Instrument location			Measurement		Type
		Zone	Elev (1). / Position	Medium	Quantity	Dim	
1-	TC-C0-I00	Tube 0 – Inner tube	Inlet	Water	Temperature	°C	D=0.5mm
2-Y	TC-C0-I01	Tube 0 – Inner tube	Outlet	Water	Temperature	°C	D=0.5mm
3-Y-	TC-C0-O15	Tube 0 – Second tube	1500mm	Water	Temperature	°C	D=0.5mm
4-Y-	TC-C0-O18	Tube 0 – Second tube	1800mm	Water	Temperature	°C	D=0.5mm
5-Y	TC-C0-O21	Tube 0 – Second tube	2100mm	Water	Temperature	°C	D=0.5mm
6-Y	TC-C0-O24	Tube 0 – Second tube	2400mm	Water	Temperature	°C	D=0.5mm
7-Y	TC-C0-O27	Tube 0 – Second tube	2700mm	Water	Temperature	°C	D=0.5mm
8-Y	TC-C0-O30	Tube 0 – Second tube	3000mm	Water	Temperature	°C	D=0.5mm
9-Y	TC-C0-O33	Tube 0 – Second tube	3300mm	Water	Temperature	°C	D=0.5mm
10-Y	TC-C0-O36	Tube 0 – Second tube	3600mm	Water	Temperature	°C	D=0.5mm
11-Y	TC-C0-O39	Tube 0 – Second tube	3900mm	Water	Temperature	°C	D=0.5mm
12-Y	TC-C0-O42	Tube 0 – Second tube	4200mm	Water	Temperature	°C	D=0.5mm
13-Y	TC-C0-O60	Tube 0 – Second tube	6000mm	Water	Temperature	°C	D=0.5mm
14-Y	TC-C0-O70	Tube 0 – Second tube	7016mm	Water	Temperature	°C	D=0.5mm
15-Y	TC-W0-W68	Tube 0 – Inner tube	6800mm	Wall – Water	Temperature	°C	D=0.5mm
16	TC-W0-P15	Tube 0 – Second tube	1500mm / 0°	Wall – SiC	Temperature	°C	D=0.5mm BROKEN
17	TC-W0-P30	Tube 0 – Second tube	3000mm / 0°	Wall – SiC	Temperature	°C	D=0.5mm BROKEN
18	TC-W0-P40	Tube 0 – Second tube	4200mm / 0°	Wall – SiC	Temperature	°C	D=0.5mm BROKEN
19	TC-W0-P60	Tube 0 – Second tube	6000mm / 0°	Wall – SiC	Temperature	°C	D=0.5mm BROKEN
20-Y	TC-W0-L10	Tube 0 – Third tube	1500mm / 0°	Wall – LBE	Temperature	°C	D=1mm
21-Y	TC-W0-L11	Tube 0 – Third tube	1500mm / 120°	Wall – LBE	Temperature	°C	D=1mm
22-Y	TC-W0-L12	Tube 0 – Third tube	1500mm / 240°	Wall – LBE	Temperature	°C	D=1mm
23-Y	TC-W0-L30	Tube 0 – Third tube	3000mm / 0°	Wall – LBE	Temperature	°C	D=1mm
24-Y	TC-W0-L31	Tube 0 – Third tube	3000mm / 120°	Wall – LBE	Temperature	°C	D=1mm
25-Y	TC-W0-L32	Tube 0 – Third tube	3000mm / 240°	Wall – LBE	Temperature	°C	D=1mm
26-Y	TC-W0-L40	Tube 0 – Third tube	4200mm / 0°	Wall – LBE	Temperature	°C	D=1mm
27-Y	TC-W0-L41	Tube 0 – Third tube	4200mm / 120°	Wall – LBE	Temperature	°C	D=1mm
28-Y	TC-W0-L42	Tube 0 – Third tube	4200mm / 240°	Wall – LBE	Temperature	°C	D=1mm
29-Y	TC-W0-L60	Tube 0 – Third tube	6000mm / 0°	Wall – LBE	Temperature	°C	D=1mm
30-Y	TC-W0-L61	Tube 0 – Third tube	6000mm / 120°	Wall – LBE	Temperature	°C	D=1mm
31-Y	TC-W0-L62	Tube 0 – Third tube	6000mm / 240°	Wall – LBE	Temperature	°C	D=1mm
32	TC-C1-I00	Tube 1 – Inner tube	Inlet	Water	Temperature	°C	D=0.5mm
33-Y	TC-C1-O70	Tube 1 – Second tube	7016mm	Water	Temperature	°C	D=0.5mm
34	TC-C2-I00	Tube 2 – Inner tube	Inlet	Water	Temperature	°C	D=0.5mm
35-Y	TC-C2-O70	Tube 2 – Second tube	7016mm	Water	Temperature	°C	D=0.5mm
36	TC-C3-I00	Tube 3 – Inner tube	Inlet	Water	Temperature	°C	D=0.5mm
37-Y	TC-C3-O70	Tube 3 – Second tube	7016mm	Water	Temperature	°C	D=0.5mm
38	TC-C4-I00	Tube 4 – Inner tube	Inlet	Water	Temperature	°C	D=0.5mm
39-Y	TC-C4-O70	Tube 4 – Second tube	7016mm	Water	Temperature	°C	D=0.5mm
40	TC-C5-I00	Tube 5 – Inner tube	Inlet	Water	Temperature	°C	D=0.5mm
41Y	TC-C5-O70	Tube 5 – Second tube	7016mm	Water	Temperature	°C	D=0.5mm
42	TC-C6-I00	Tube 6 – Inner tube	Inlet	Water	Temperature	°C	D=0.5mm
43-Y	TC-C6-O70	Tube 6 – Second tube	7016mm	Water	Temperature	°C	D=0.5mm
44-Y	TC-W1-L11	Tube 1 – Third tube	1500mm / 120°	Wall – LBE	Temperature	°C	D=1mm
45-Y	TC-W2-L12	Tube 2 – Third tube	1500mm / 240°	Wall – LBE	Temperature	°C	D=1mm
46-Y	TC-W1-L31	Tube 1 – Third tube	3000mm / 120°	Wall – LBE	Temperature	°C	D=1mm

#	ID	Instrument location			Measurement		Type
		Zone	Elev (1). / Position	Medium	Quantity	Dim	
47-Y	TC-W2-L32	Tube 2 – Third tube	3000mm / 240°	Wall – LBE	Temperature	°C	D=1mm
48-Y	TC-W1-L41	Tube 1 – Third tube	4200mm / 120°	Wall – LBE	Temperature	°C	D=1mm
49-Y	TC-W2-L42	Tube 2 – Third tube	4200mm / 240°	Wall – LBE	Temperature	°C	D=1mm
50-Y	TC-01-L15	Sub-channel 1 centre	1500mm	LBE	Temperature	°C	D=1mm
51-Y	TC-07-L15	Sub-channel 7 centre	1500mm	LBE	Temperature	°C	D=1mm
52-Y	TC-09-L15	Sub-channel 9 centre	1500mm	LBE	Temperature	°C	D=1mm
53-Y	TC-11-L15	Sub-channel 11 centre	1500mm	LBE	Temperature	°C	D=1mm
54-Y	TC-01-L30	Sub-channel 1 centre	3000mm	LBE	Temperature	°C	D=1mm
55-Y	TC-07-L30	Sub-channel 7 centre	3000mm	LBE	Temperature	°C	D=1mm
56-Y	TC-09-L30	Sub-channel 9 centre	3000mm	LBE	Temperature	°C	D=1mm
57-Y	TC-11-L30	Sub-channel 11 centre	3000mm	LBE	Temperature	°C	D=1mm
58-Y	TC-01-L42	Sub-channel 1 centre	4200mm	LBE	Temperature	°C	D=1mm
59-Y	TC-07-L42	Sub-channel 7 centre	4200mm	LBE	Temperature	°C	D=1mm
60-Y	TC-09-L42	Sub-channel 9 centre	4200mm	LBE	Temperature	°C	D=1mm
61-Y	TC-11-L42	Sub-channel 11 centre	4200mm	LBE	Temperature	°C	D=1mm
62	TC-SL-W01	Steam-chamber outlet	--	Water	Temperature	°C	D=1mm
63	TC-SL-W02	Steam-chamber outlet	--	Water	Temperature	°C	D=1mm
64	TC-SL-W03	Steam-chamber outlet	--	Water	Temperature	°C	D=1mm
65	TC-SL-W04	Steam-chamber outlet	--	Water	Temperature	°C	D=1mm
DP-C0-W00 to DP-C6-W02							
1	DP-C0-W00	Tube 0	Overall	Water	Press. diff.	kPa	
2	DP-C0-W01	Tube 0	Descending	Water	Press. diff.	kPa	
3	DP-C0-W02	Tube 0	Ascending	Water	Press. diff.	kPa	
4	DP-C1-W00	Tube 1	Overall	Water	Press. diff.	kPa	
5	DP-C1-W01	Tube 1	Descending	Water	Press. diff.	kPa	
6	DP-C1-W02	Tube 1	Ascending	Water	Press. diff.	kPa	
7	DP-C2-W00	Tube 2	Overall	Water	Press. diff.	kPa	
8	DP-C2-W01	Tube 2	Descending	Water	Press. diff.	kPa	
9	DP-C2-W02	Tube 2	Ascending	Water	Press. diff.	kPa	
10	DP-C3-W00	Tube 3	Overall	Water	Press. diff.	kPa	
11	DP-C3-W01	Tube 3	Descending	Water	Press. diff.	kPa	
12	DP-C3-W02	Tube 3	Ascending	Water	Press. diff.	kPa	
13	DP-C4-W00	Tube 4	Overall	Water	Press. diff.	kPa	
14	DP-C4-W01	Tube 4	Descending	Water	Press. diff.	kPa	
15	DP-C4-W02	Tube 4	Ascending	Water	Press. diff.	kPa	
16	DP-C5-W00	Tube 5	Overall	Water	Press. diff.	kPa	
17	DP-C5-W01	Tube 5	Descending	Water	Press. diff.	kPa	
18	DP-C5-W02	Tube 5	Ascending	Water	Press. diff.	kPa	
19	DP-C6-W00	Tube 6	Overall	Water	Press. diff.	kPa	
20	DP-C6-W01	Tube 6	Descending	Water	Press. diff.	kPa	
21	DP-C6-W02	Tube 6	Ascending	Water	Press. diff.	kPa	
PC-00-I00 to PC-00-O00							
22	PC-00-I00	FW collector	--	Water	Pressure	MPa	
22	PC-00-O00	Steam collector	--	Water	Pressure	MPa	
MF-00-I00 to MF-02-I00							
1	MF-00-I00	Tube 0 – inlet	--	Water	Mass flow	g/s	
2	MF-01-I00	Tube 1 – inlet	--	Water	Mass flow	g/s	
3	MF-02-I00	Tube 2 – inlet	--	Water	Mass flow	g/s	

#	ID	Instrument location			Measurement		Type
		Zone	Elev (1). / Position	Medium	Quantity	Dim	
4	MF-03-I00	Tube 3 – inlet	--	Water	Mass flow	g/s	
5	MF-04-I00	Tube 4 – inlet	--	Water	Mass flow	g/s	
6	MF-05-I00	Tube 5 – inlet	--	Water	Mass flow	g/s	
7	MF-06-I00	Tube 6 – inlet	--	Water	Mass flow	g/s	
8	MF-FW-I00	FW collector	--	Water	Mass flow	g/s	

(1) 0.00m located at tube bottom

Tab. 9 – HERO-CIRCE SGBT unit, instrumentation.

Central byonet tube

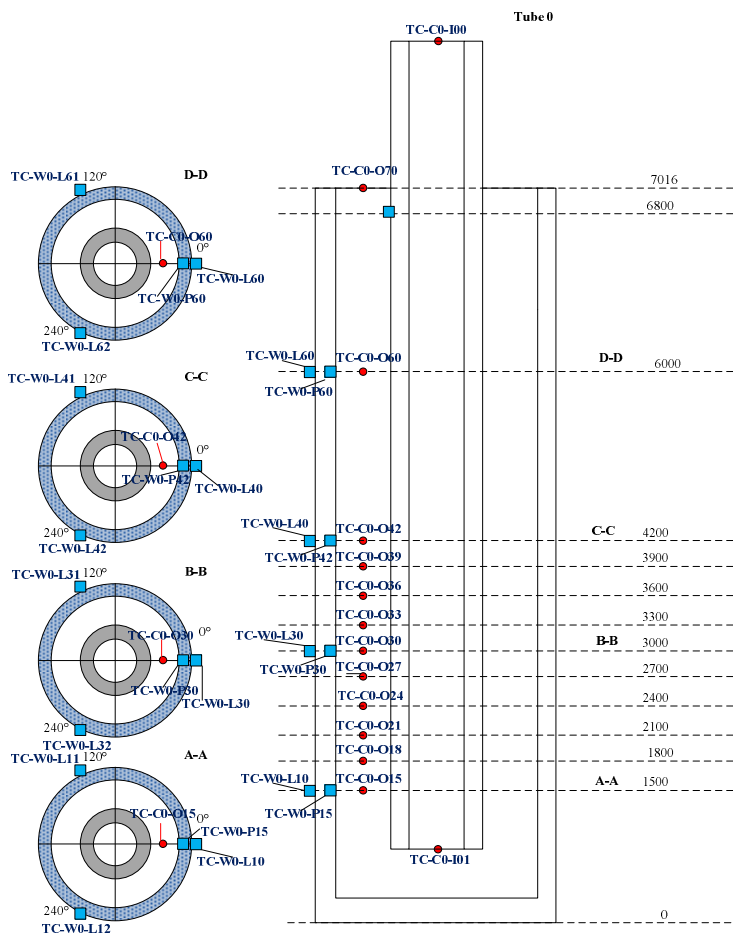

Fig. 16 – HERO-CIRCE SGBT unit instrumentation: TCs in the central tube.

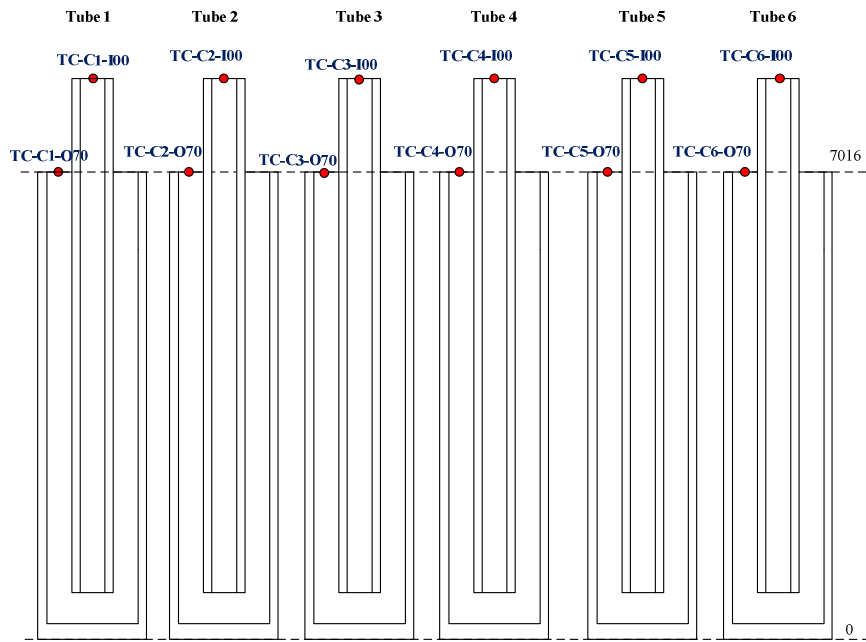

Fig. 17 – HERO-CIRCE SGBT unit instrumentation: TCs in tubes 1-2-3-4-5-6.

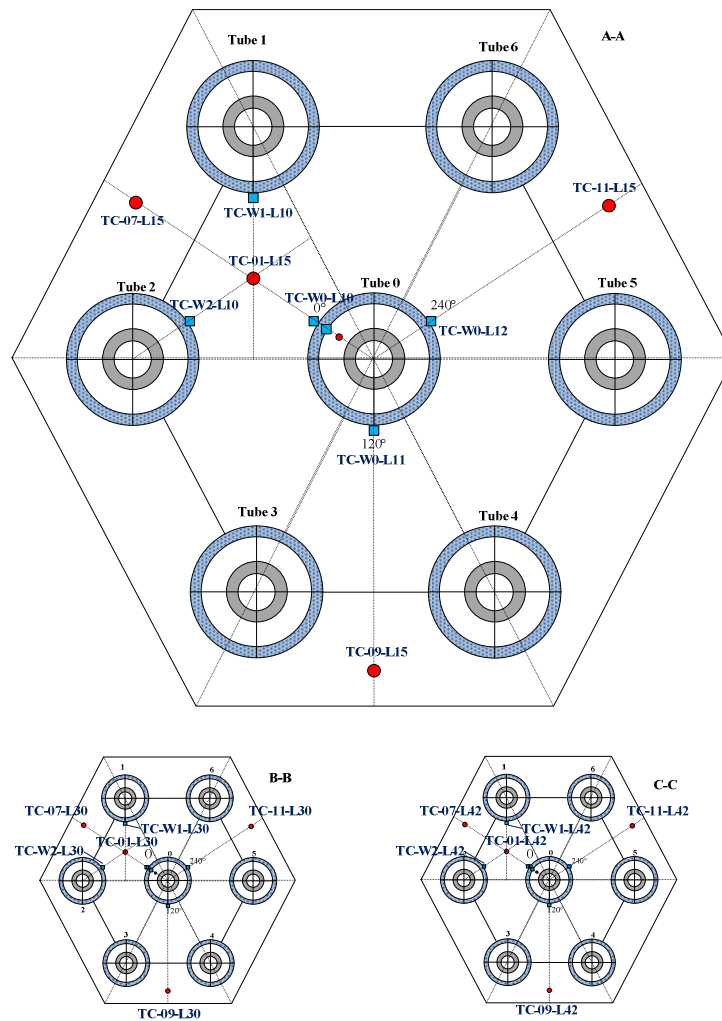

Fig. 18 – HERO-CIRCE SGBT unit instrumentation: TCs in the LBE channel.



(a) TC in the central tube wall



(a) TCs in the lead sub-channels

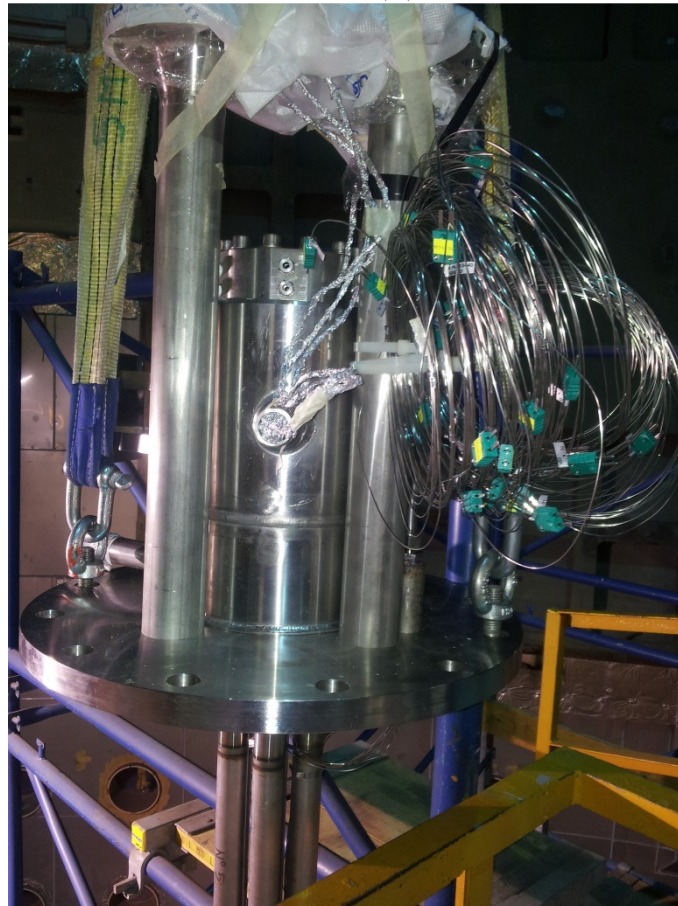

(c) TC exit (both steam-water side from the steam chamber and the LBE side from the flange)

Fig. 19 – HERO-CIRCE SGBT unit instrumentation: TCs.

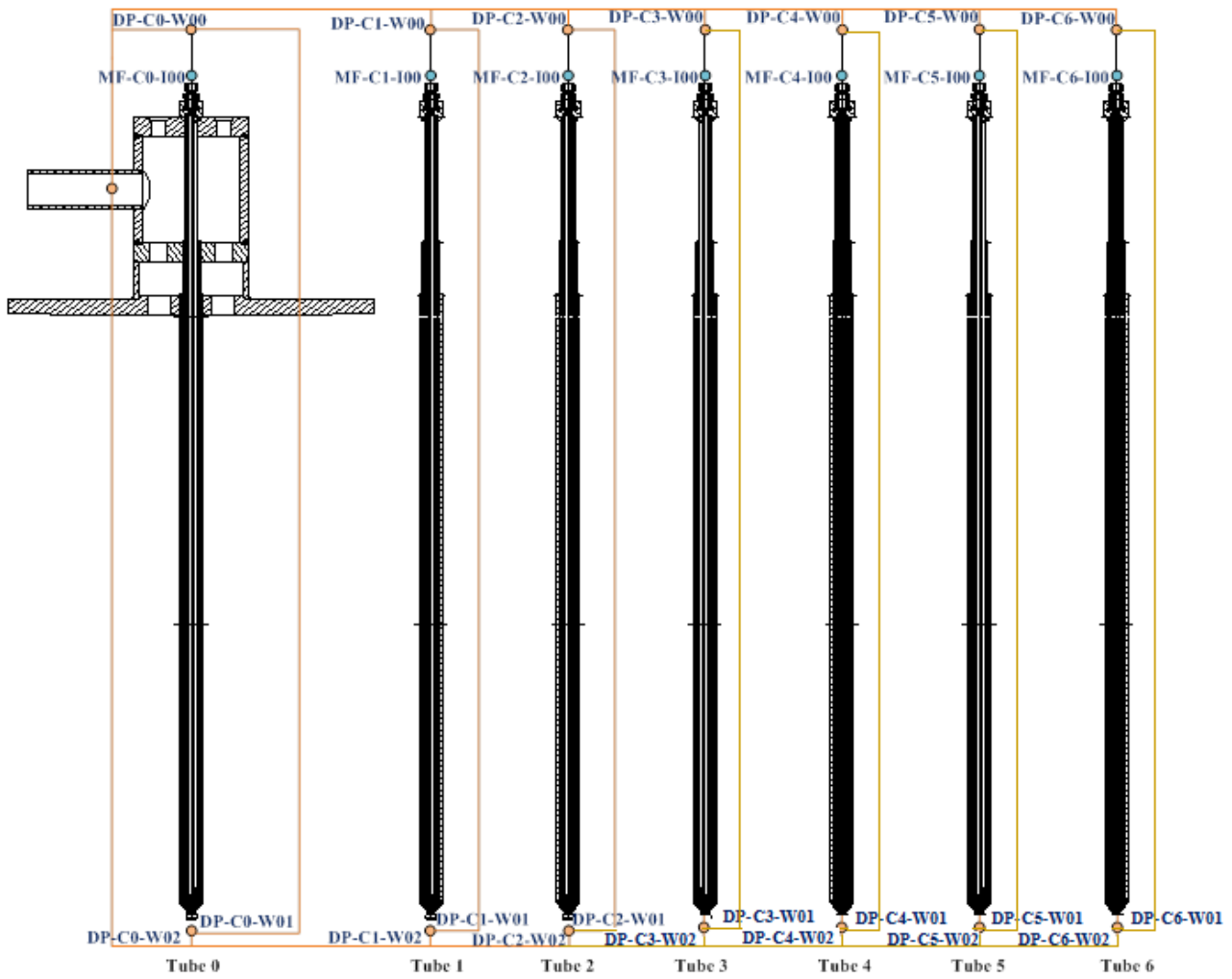

Fig. 20 – HERO-CIRCE SGBT unit instrumentation: pressure transducers and mass-flow meters in the steam-water side.

2.2 Modeling of the Bayonet Tube SG unit by RELAP-5

The SGBT unit has been modeled by means of RELAP version 3.3^{[4][5][6]}. A schematic overview of the nodalization adopted is reported in *Fig. 21* and *Fig. 22*. The model includes: one single tube that represents seven tubes. In particular, the following main hydrodynamic components are considered: the feed-water tube (pipe 100), the annular steam riser (pipe 110), the equivalent lead channel (pipe 140), the steam plenum (branch 111) and the argon zone (branch 136). The analysis has been developed on the basis of the following assumptions:

- The heat exchange between the annular steam riser and the Argon zone has been neglected, that means adiabatic behavior of the non-active outer-side tube surface region.
- The materials and the geometry are according to the design of HERO.
- The powder (AISI-316) conductivity is according to the experimental finding achieved in the TxP campaign (Eq. 3).
- The heat transfer between the lead side and the annular riser is modeled according to the Mikityuk correlation that has been developed for fuel rod bundle **Errore. L'origine riferimento non è stata trovata.**
- The hexagonal wrap has been considered in the model.
- The spacer grids are modeled as concentrated pressure drops calculated according to Ref. **Errore. L'origine riferimento non è stata trovata.**

The description of the main hydrodynamic components is given in *Tab. 10*, *Tab. 11* and *Tab. 12*. The heat structures are summarized from *Tab. 13* to *Tab. 15*.

The main results are summarized in *Tab. 16*. *Fig. 23* reports the fluid temperature in the bayonet tube, the void fraction in the annular riser and the LBE temperature in the corresponding channel and. The system is capable to remove 443 kW (*Tab. 16*) and the submerged maximum steam temperature is about 400°C. The fluid becomes 95% steam after the 3.4m.

Fig. 24 highlights the profile velocities of the fluids along the bayonet tube. They contribute to a pressure drop mainly concentrated in the annular riser in the order of 1.69 bar (*Tab. 16*).

$$C_{He-4bar} = 5 * 10^{-6}T^2 + 8 * 10^{-4}T + 1.3198 \quad Eq. 3$$

Where T is temperature [°C]

Description	Unit	Quantity	Notes
Label	--	--	Pipe-100 slave tube
Flow area	m ²	2.763635 10 ⁻⁴	
N° axial volumes	--	49	--
Axial volume basic length	m	0.15000	
Axial volume lengths: min - max	m	0.13125 – 0.21000	--
Angle	°	-90	--
Wall roughness	m	3.2 10 ⁻⁶	--
Reynolds energy loss coefficient	--	1.00 10 ⁻³	--
Hydraulic diameter	m	7.09 10 ⁻³	--
Reynolds reverse energy loss coefficient	--	1.00 10 ⁻³	--
Pressure	Pa	1.72 10 ⁷	--
Temperature	K	608	--
Mass flow	kg/s	3.3078510 ⁻¹	--

Tab. 10 – HERO-CIRCE SGBT unit modelling: hydrodynamic component pipe 100.

Description	Unit	Quantity	Notes
Label	--	--	Pipe-110 annular riser
Flow area	m ²	4.711049 10 ⁻⁴	--
N° axial volumes	--	48	--
Axial volume basic length	m	0.15000	--
Axial volume lengths: min - max	m	0.13125 – 0.17800	--
Angle	°	+90	--
Wall roughness	m	3.2 10 ⁻⁶	--
Reynolds energy loss coefficient	--	1.00 10 ⁻³	--
Hydraulic diameter	m	2.13 10 ⁻³	--
Reynolds reverse energy loss coefficient	--	1.00 10 ⁻³	--
Pressure	Pa	1.72 10 ⁷	--
Temperature	K	608	--
Mass flow	kg/s	3.3078510 ⁻¹	--

Tab. 11 – HERO-CIRCE SGBT unit modelling: hydrodynamic component pipe 110.

Description	Unit	Quantity	Notes
Label	--	--	Channel-140 lead channel
Flow area	m ²	7.616311 10 ⁻³	
N° axial volumes	--	41	--
Axial volume basic length	m	0.15000	--
Axial volume lengths: min - max	m	0.13125 0.17800	--
Angle	°	+90	--
Wall roughness	m	3.2 10 ⁻⁶	--
Reynolds energy loss coefficient	--	1.00 10 ⁻³	--
Hydraulic diameters	m	2.6017 10 ⁻²	--
Reynolds reverse energy loss coefficient	--	1.00 10 ⁻³	--
Pressure	Pa	1.0-7.0 10 ⁶	--
Temperature	K	608	--
Mass flow	kg/s	44.573529	--

Tab. 12 – HERO-CIRCE SGBT unit modelling: hydrodynamic component channel 140.

COMPONENT LABEL	TYPE	DESCRIPTION	
<i>Heat structure</i>	1100	Heat transfer between feed-water and riser	
Parameter	Unit	Quantity	Notes
Axial heat structures n°	--	49	--
Radial meshes n°	--	20	--
Slave tube inner radius	m	3.545 10 ⁻³	--
Slave tube outer radius	m	4.765 10 ⁻³	--
Slave tube radial nodes n°	--	5	
Gap outer radius	m	7.875 10 ⁻³	--
Gap radial nodes n°	--	9	--
Inner tube outer radius	m	9.525 10 ⁻³	--
Inner tube radial node n°	--	5	--
Slave tube material	--	AISI-316	--
Gap material	--	Air	--
First tube material		AISI-316	--
Temperature	K	700	--
Multiplying factor	--	7	Applied on the heated length
Heat transfer left diameter	m	7.090 10 ⁻³	--
Heat transfer right diameter	m	4.498 10 ⁻³	-

Tab. 13 – HERO-CIRCE SGBT unit modelling: heat structure between the feed-water tube and the annular riser.

COMPONENT LABEL	TYPE	DESCRIPTION	
<i>Heat structure</i>	1110	Heat transfer between Pipe 110 - 140	
Parameter	Unit	Quantity	Notes
Axial heat structures n°	--	41	--
Radial meshes n°	--	31	--
Second tube inner radius	m	$1.059 \cdot 10^{-2}$	--
Second tube outer radius	m	$1.270 \cdot 10^{-2}$	--
Second tube radial nodes n°	10	10	--
Gap outer radius	m	$1.332 \cdot 10^{-2}$	--
Gap radial nodes n°	--	10	--
Third tube outer radius	m	$1.670 \cdot 10^{-2}$	--
Third tube radial nodes n°	--	10	--
Second tube material	--	AISI-316	--
Gap material	--	AISI-316 powder	--
Third tube material	--	AISI-316	--
Temperature	K	608	--
Multiplying factor	--	7	Applied on the heated length
Heat transfer left diameter	m	$4.0467 \cdot 10^{-3}$	--
Heat transfer right diameter	m	0.040930	--

Tab. 14 – HERO-CIRCE SGBT unit modelling: heat structure between the annular riser and lead channel.

COMPONENT LABEL	TYPE	DESCRIPTION	
<i>Heat structure</i>	1200	Heat transfer between Hexagonal wall – Outer wall	
Parameter	Unit	Quantity	Other
Axial heat structures n°	--	41	--
Radial meshes n°	--	22	--
Hexagonal wall inner radius	m	$6.3 \cdot 10^{-2}$	--
Hexagonal wall radius	m	$6.45 \cdot 10^{-2}$	--
Hexagonal wall radial nodes n°	--	7	--
Gap outer radius	m	$8.075 \cdot 10^{-2}$	--
Gap radial nodes n°	--	7	--
Cylinder wall outer radius	m	$8.245 \cdot 10^{-2}$	--
Cylinder wall radial nodes n°	--	7	--
Hexagonal wall material	--	AISI-316	--
Gap material	--	Air	--
Cylinder wall material	--	AISI-316	--
Temperature	K	608	--
Multiplying factor	--	7	Applied on the heated length
Heat transfer left diameter	m	4.68310^{-3}	--
Heat transfer right diameter	m	0	--

Tab. 15 – HERO-CIRCE SGBT unit modelling: heat structure between the lead channel and outer wall.

Parameter	Unit	Quantity
Lead inlet temperature	°C	478.5
Lead outlet temperature	°C	410.5
Feed-water inlet temperature	°C	334.4
Feed-water tube temperature drop	°C	334.8
Immersed tube steam temperature	°C	400.2
Superheated steam outlet temperature	°C	398.3
Void fraction	--	1.00
Pressure drop in the annular riser	bar	1.69
Lead velocity	m/s	0.57
Removed power	kW	447

Tab. 16 – HERO-CIRCE SGBT unit modelling: summary of the results.

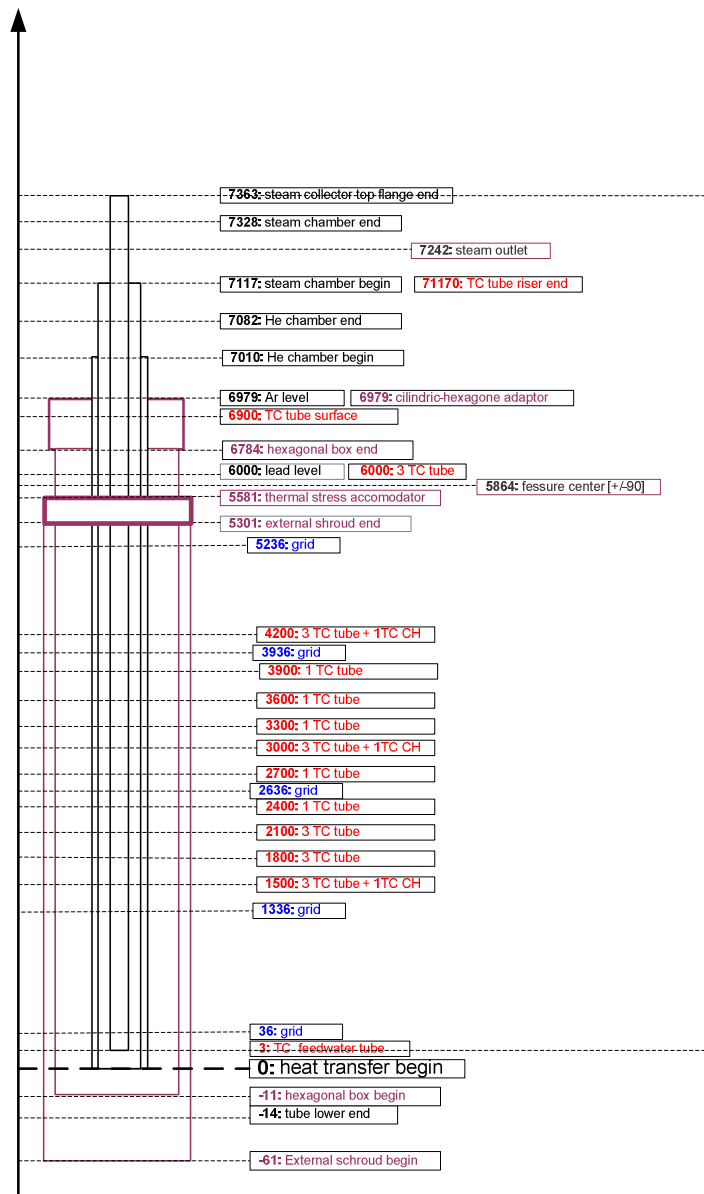

Fig. 21 – HERO-CIRCE SGBT unit modeling: axial elevations considered to develop the input deck.

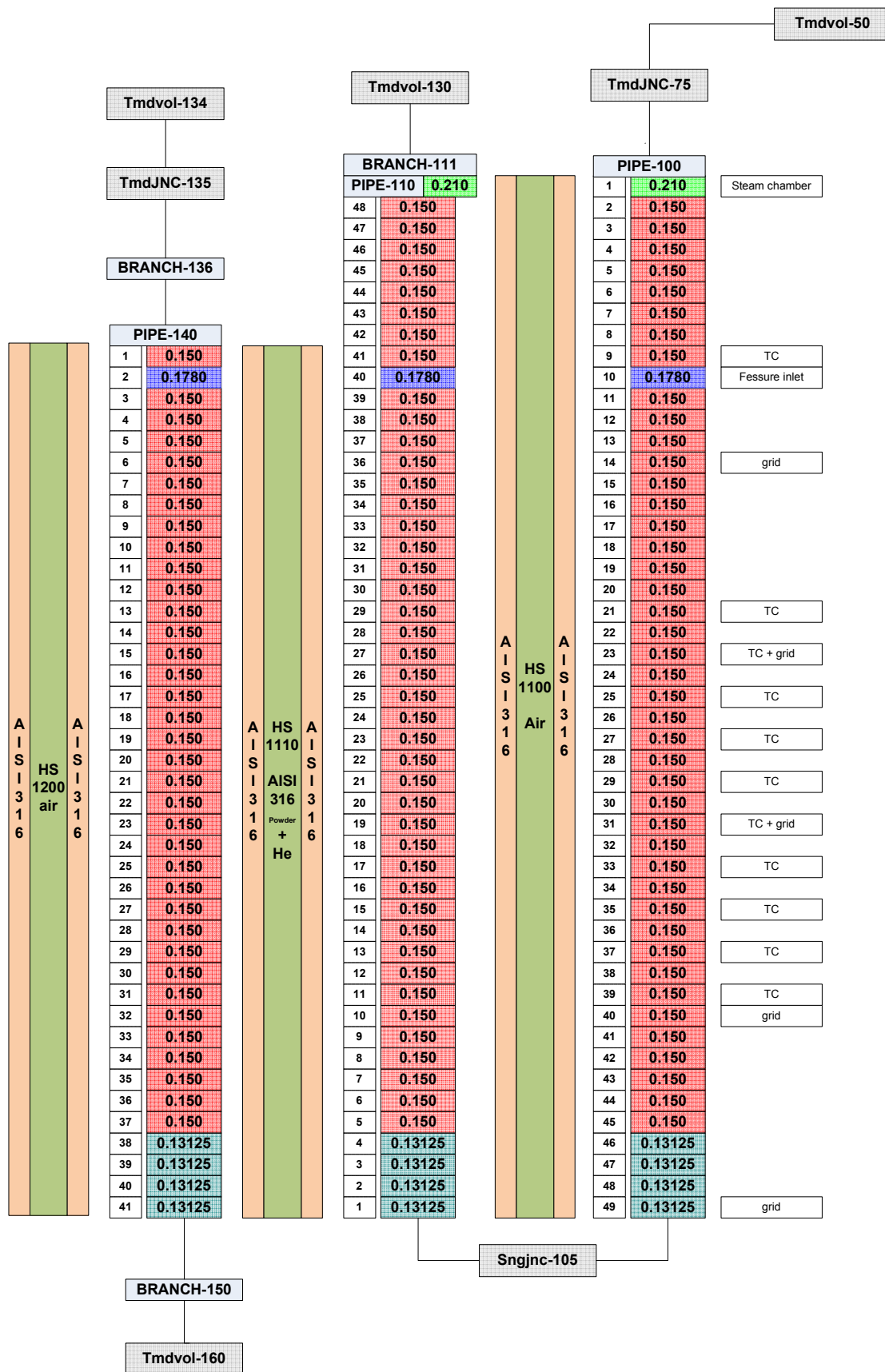

Fig. 22 – HERO-CIRCE SGBT unit modeling: nodalization scheme.

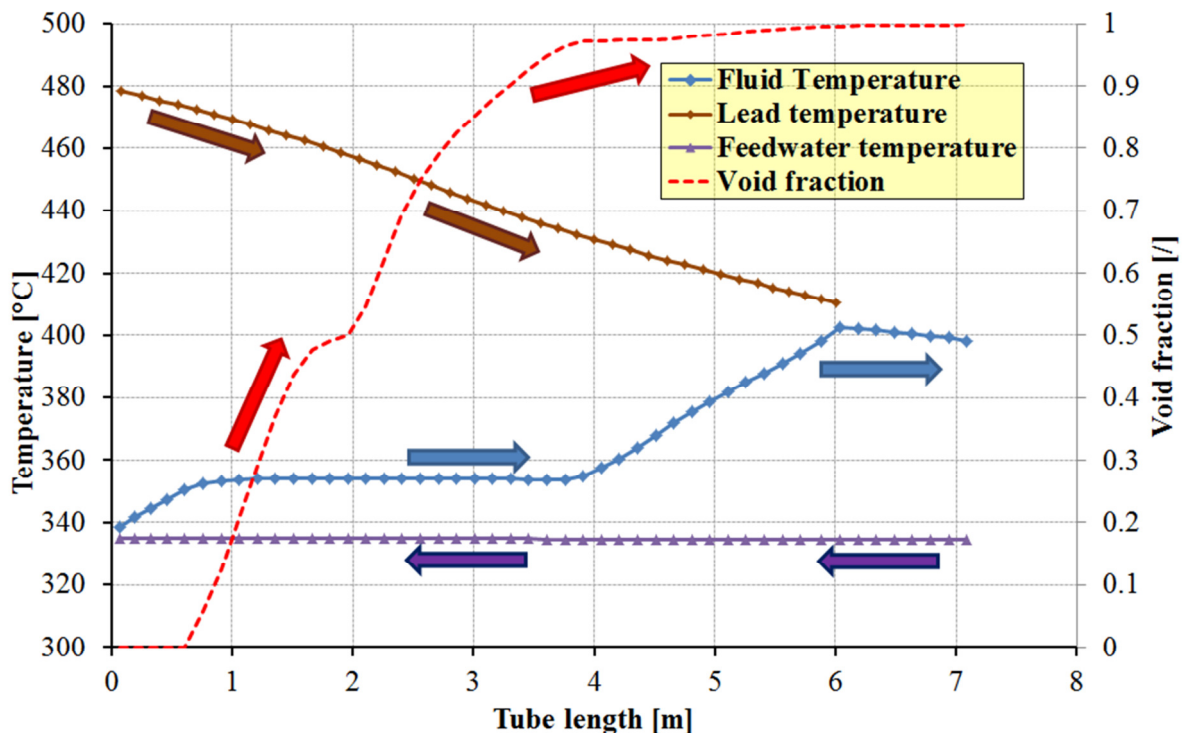

Fig. 23 – HERO-CIRCE SGBT unit vs RELAP-5 main TH parameters.

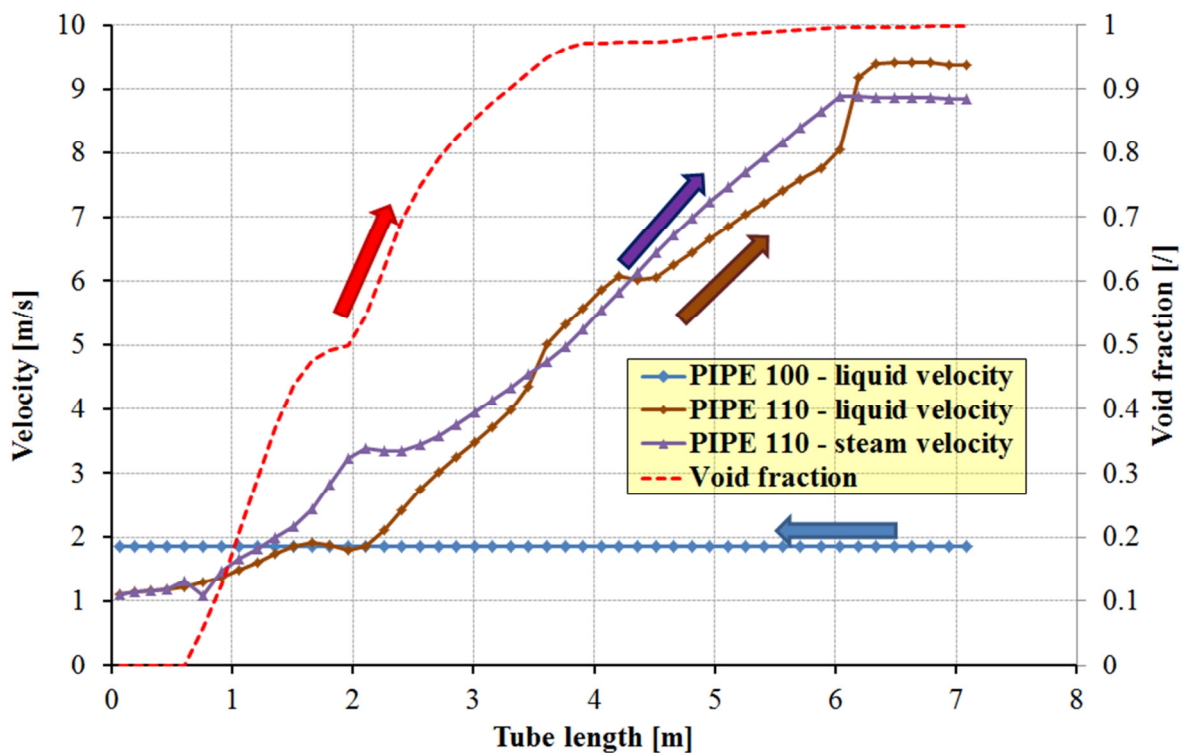



Fig. 24 – HERO-CIRCE SGBT unit vs RELAP-5 velocity profiles in the water steam side.



 Ricerca Sistema Elettrico	Sigla di identificazione	Rev.	Distrib.	Pag.
	ADPFISS – LP2 – 072	0	L	37 di 45

3 Conclusions

The present work aims to support the development of a SG whose tubes are double wall bayonet type with leakage monitoring. This configuration has been proposed by ANSALDO for the ALFRED reactor in the framework of the LEADER project. The Heavy liquid metal – pressurized water cooled tube (HERO) SG unit has been designed by ENEA in the previous year to this purpose. It is based on a hexagonal shroud that contains 7 SGBT of similar geometry to the ALFRED SG. It is designed to be placed inside CIRCE and is fed by LBE which flows by gas enhanced circulation from the top by means of fissures that communicate with the CIRCE pool. The LBE flows inside the tube bundle for six meters (as in the SG of ALFRED) and then it leaves the device from the bottom which is opened.

The construction and instrumentation of the unit has been realized in this year and required some modifications of the initial design. The most important is related to the experimental campaigns conducted in TxP that highlight low thermal conductivity of Si-C powder. AISI-316 powder was loaded instead Si-C into the unit allowing the construction of a SG unit that is expected to produce super-heated steam at 400°C, 50°C lower than the ALFRED SG goal. Two main parameters are responsible for this discrepancy:

- The tube material: stainless steel tubes require higher thicknesses than T91 and have lower conductivity.
- The powder material: AISI-316 powder has relatively low conductivity and further investigation are necessary to select alternative materials with higher conductivity.

The expected performance of HERO-CIRCE is retained acceptable for the application to a prototypic unit and can be scaled to ALFRED.

The secondary system is under design and will be finalized in the next year.

REFERENCES

- [1] *D. Rozzia, D. Martelli, N. Forgione M. Moretti, A. Naviglio, D. Vitale Di Maio A. Del Nevo, M. Tarantino* **Activities in Support to the Assessment of SG Bayonet Tubes, for GEN-IV Applications** ENEA, NNFISS - LP3 - 054, 2012
- [2] *D. Rozzia, A. Del Nevo, M. Tarantino and P.A. Gaggini.* **Fornitura scambiatore di calore a tubi a baionetta (HERO).** ADPFISS – LP2 – 028, 2013.
- [3] *M. Tarantino, et al..* **Integral Circulation Experiment: Thermal-Hydraulic Simulator of a Heavy Liquid Metal Reactor.** Journal of Nuclear Material, vol. 415, Issue 3, pp. 433-448.
- [4] *NUREG/CR-5535,* **RELAP5/MOD3.3 Code Manual, Volume IV: Models and Correlations,** Information Systems Laboratories Inc., December 2001.
- [5] *NUREG/CR-5535,* **RELAP5/MOD3.3 Code Manual, Volume I: Code Structure, System Model, and Solution Methods,** Information Systems Laboratories Inc., March 2003.
- [6] *NUREG/CR-5535,* **RELAP5/MOD3.3 Code Manual, Volume II Appendix A: Input Requirements,** Information Systems Laboratories Inc., June 2004.
- [7] *DOE NERAC, GIF,* **A Technology Roadmap for Generation IV Nuclear Energy Systems,** GIF-002-00, December 2002.
- [8] *D. Rozzia,* **Experimental and computational analyses in support to the design of a SG mock-up prototype for LFR technology applications,** PhD Thesis, to be issued in October 2014.

APPENDIX A: HERO SG bayonet tube unit main components

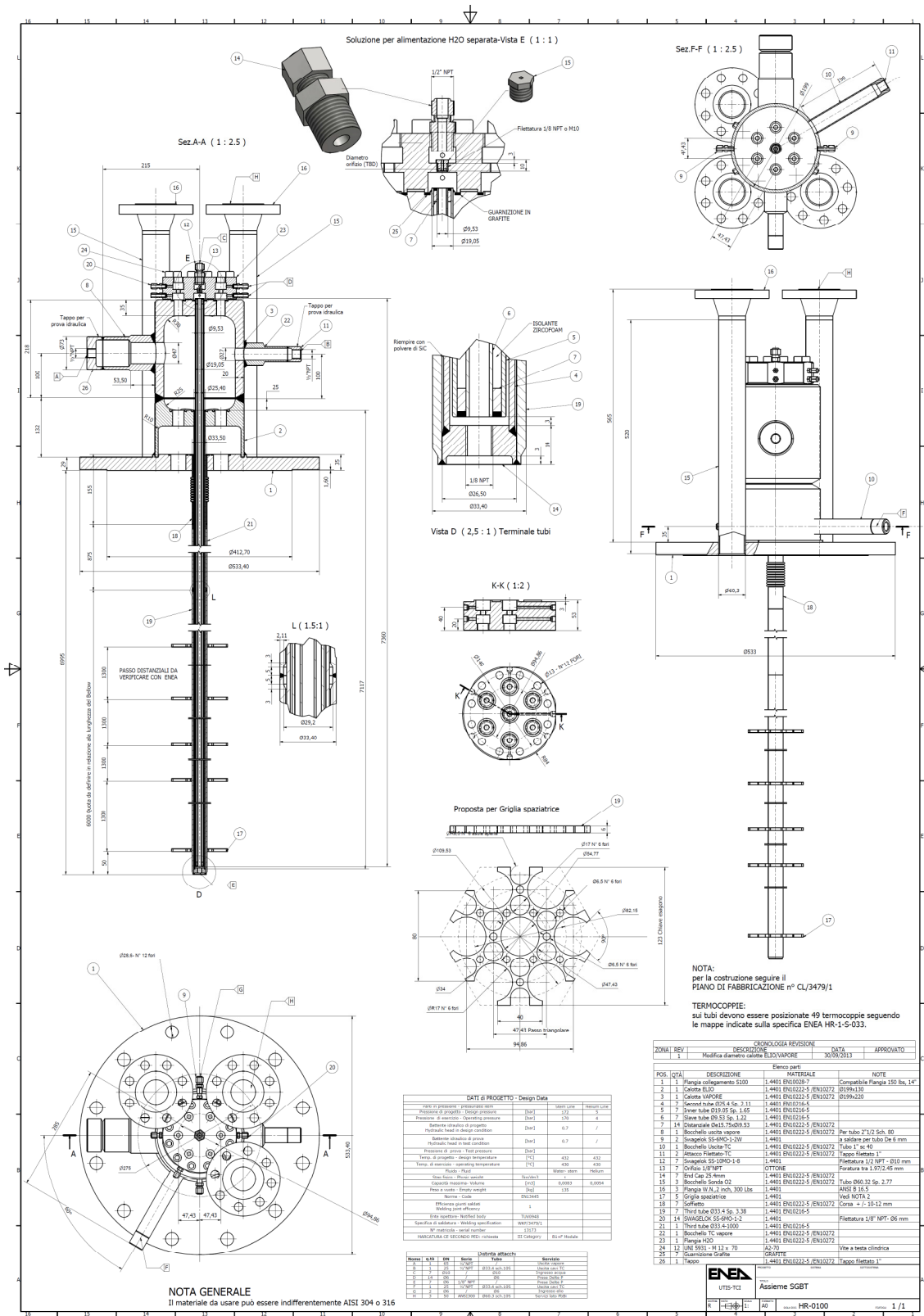

Fig. A. 1 - HERO-CIRCE SGBT unit main layout.

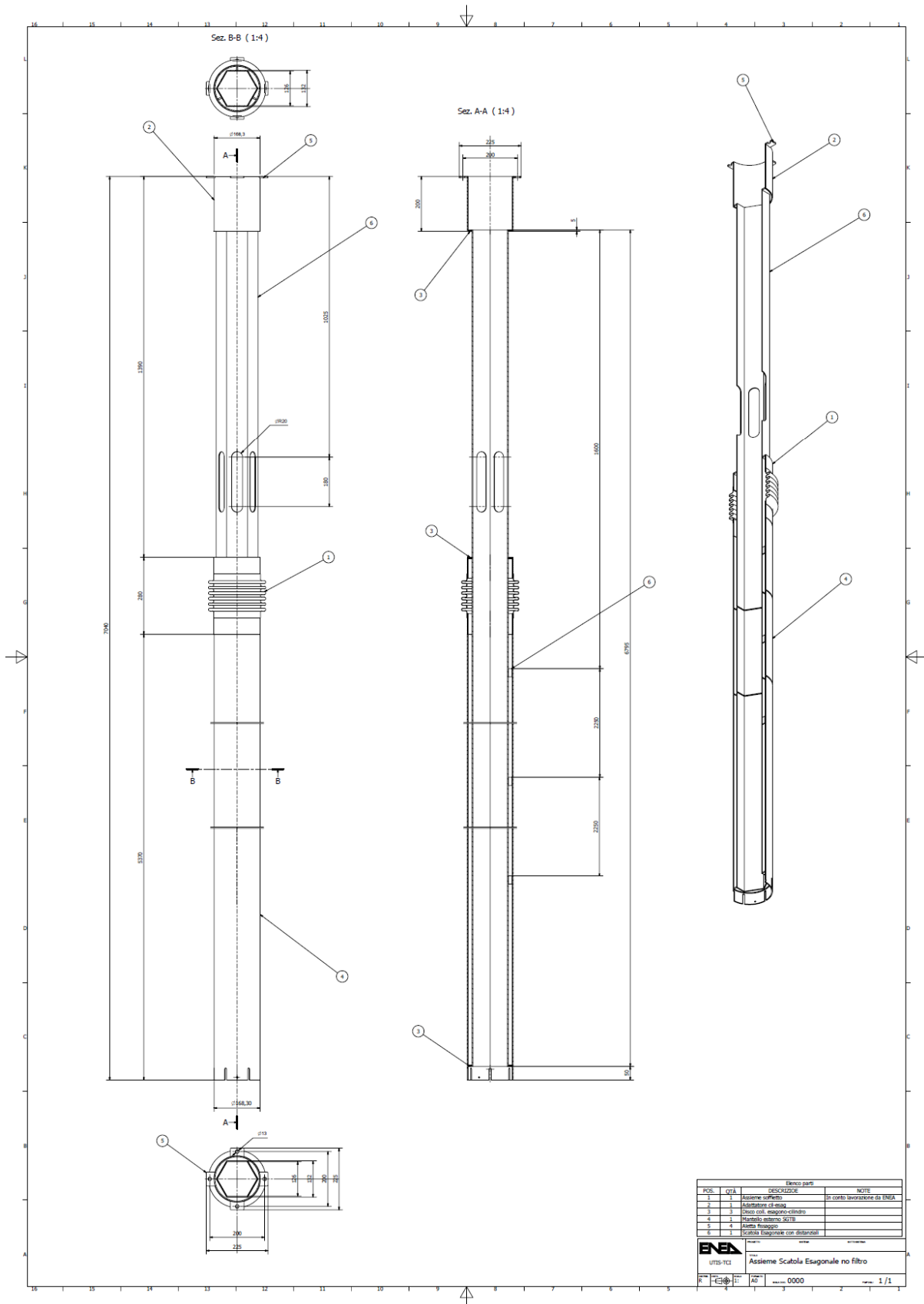

Fig. A. 2 – HERO-CIRCE SGBT external wrap layout.

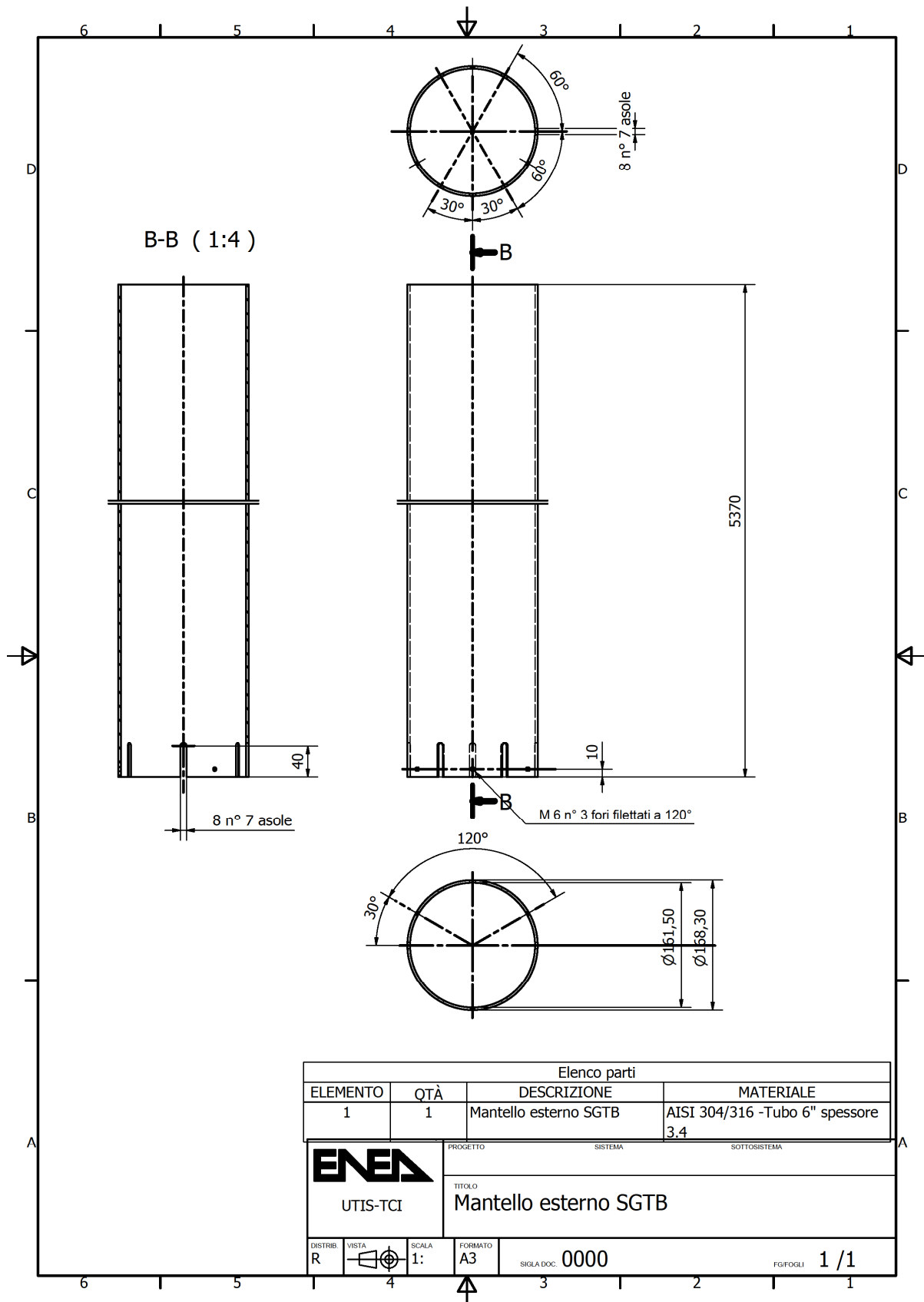

Fig. A. 3 – HERO-CIRCE SGBT wrap external shroud.

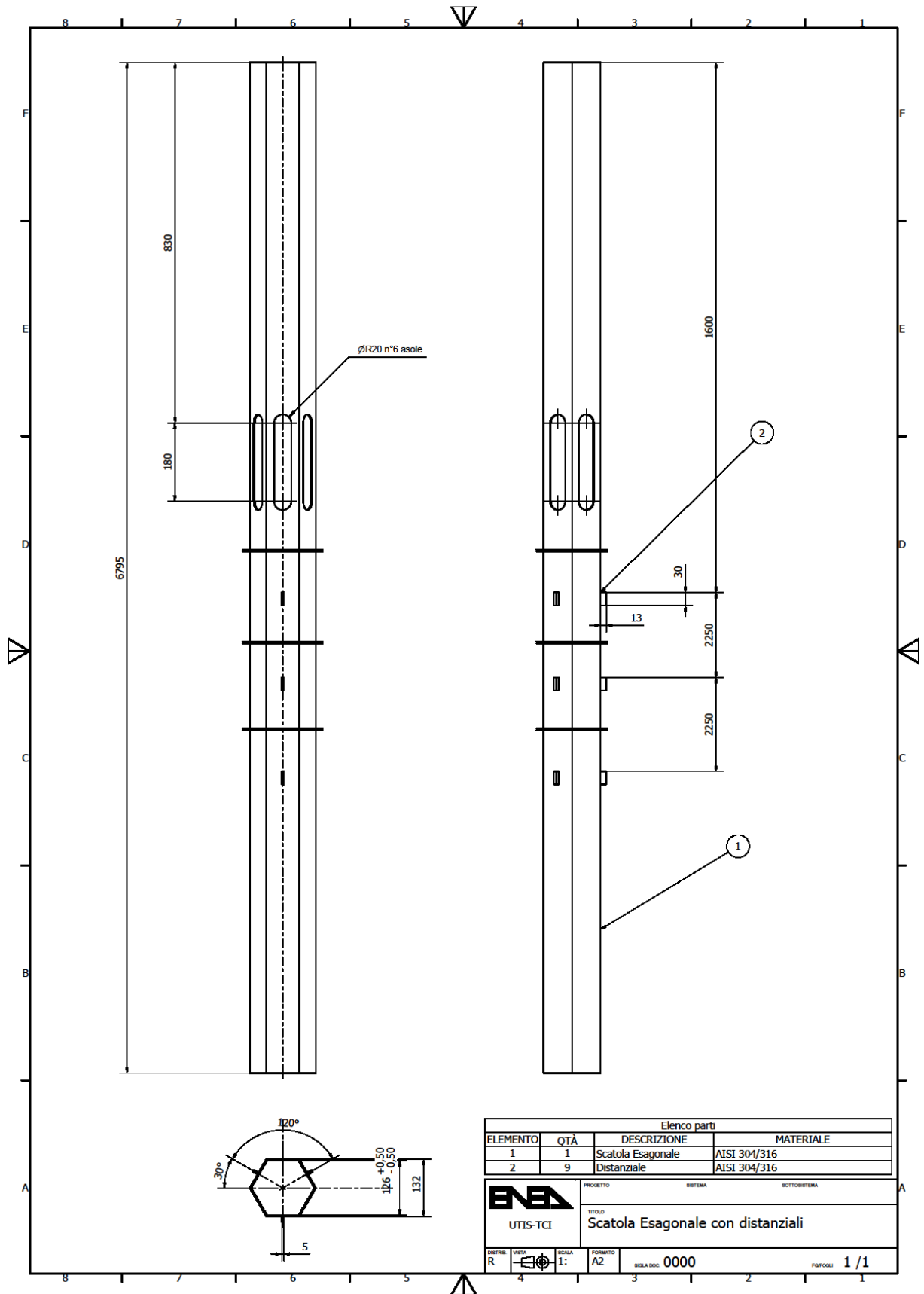

Fig. A. 4 – HERO-CIRCE SGBT hexagonal inner wrap.

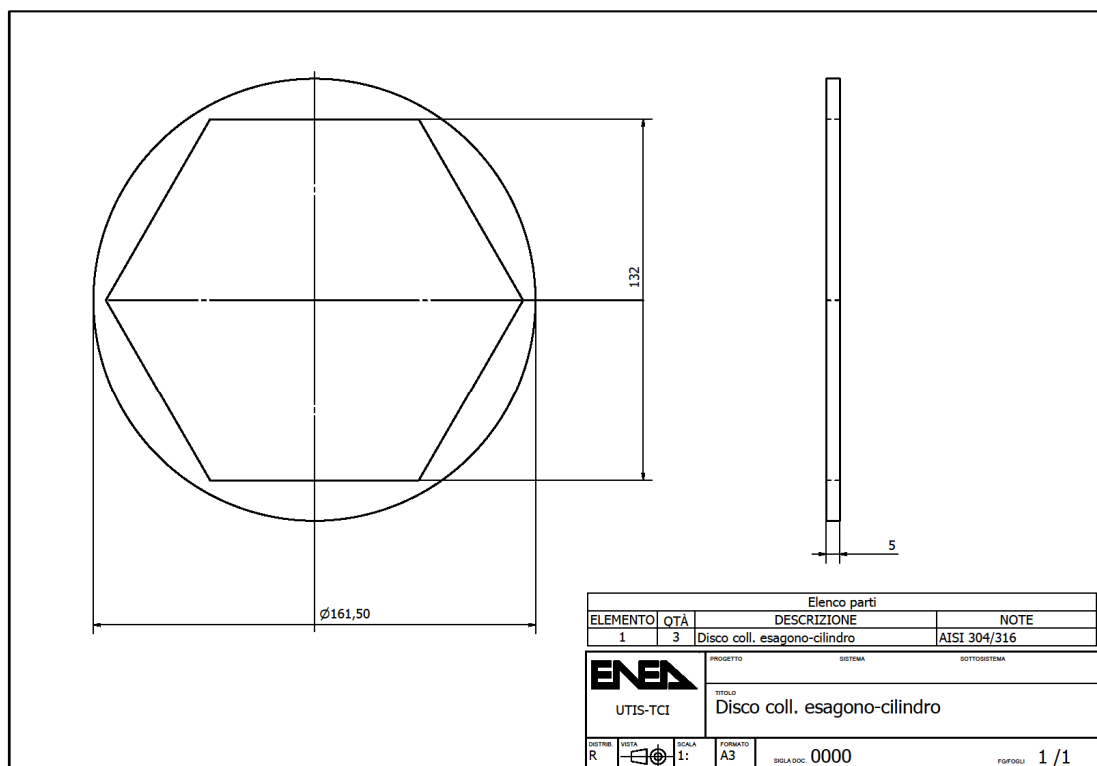

Fig. A. 5 – HERO-CIRCE SGBT hexagon cylinder adaptor.

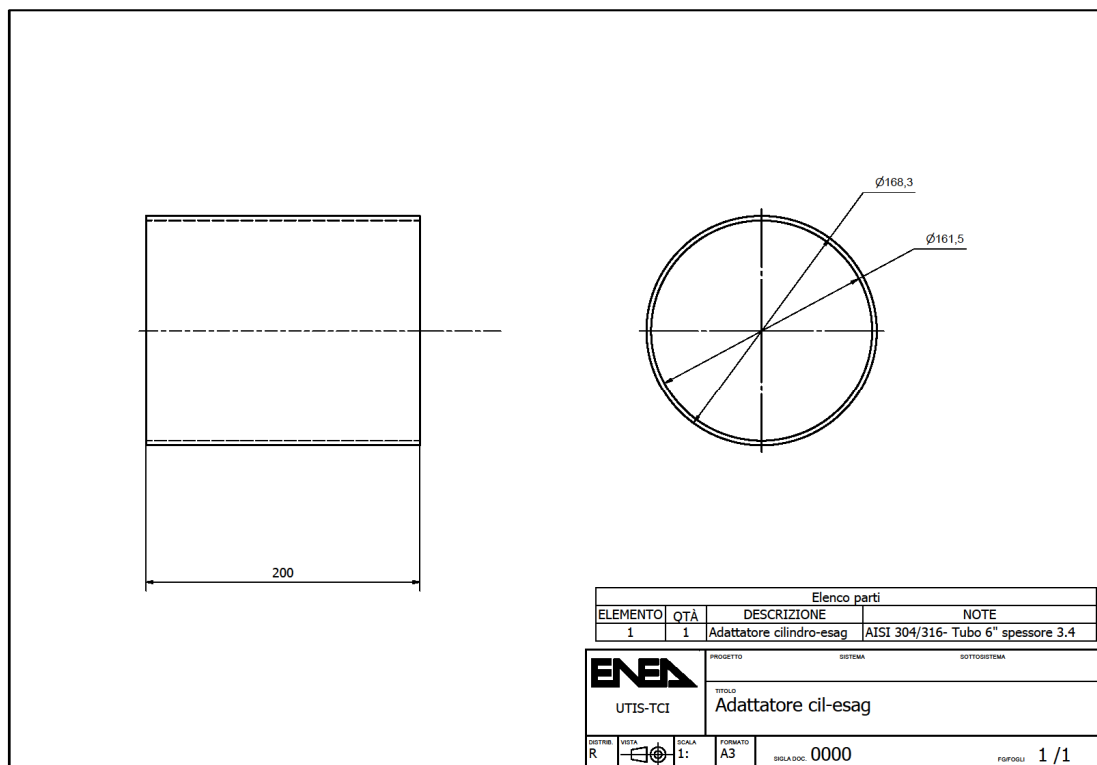

Fig. A. 6 – HERO-CIRCE SGBT hexagon cylinder adaptor.

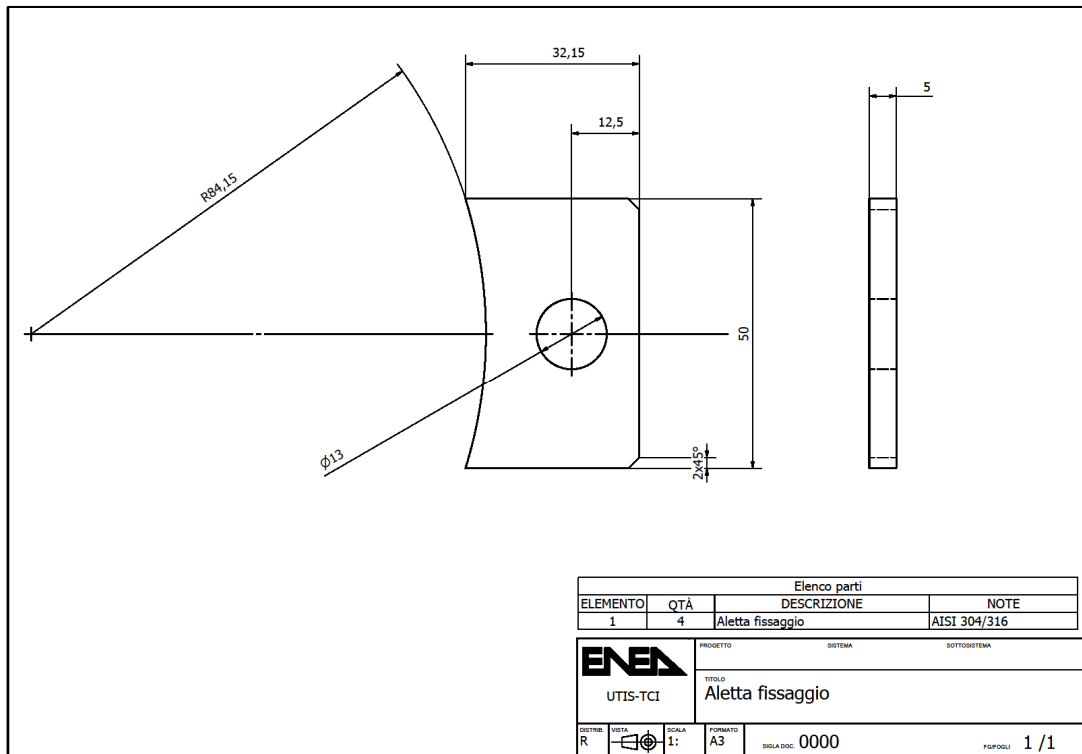

Fig. A. 7 – HERO-CIRCE SGBT fixing plate (to S-100 of CIRCE top flange).

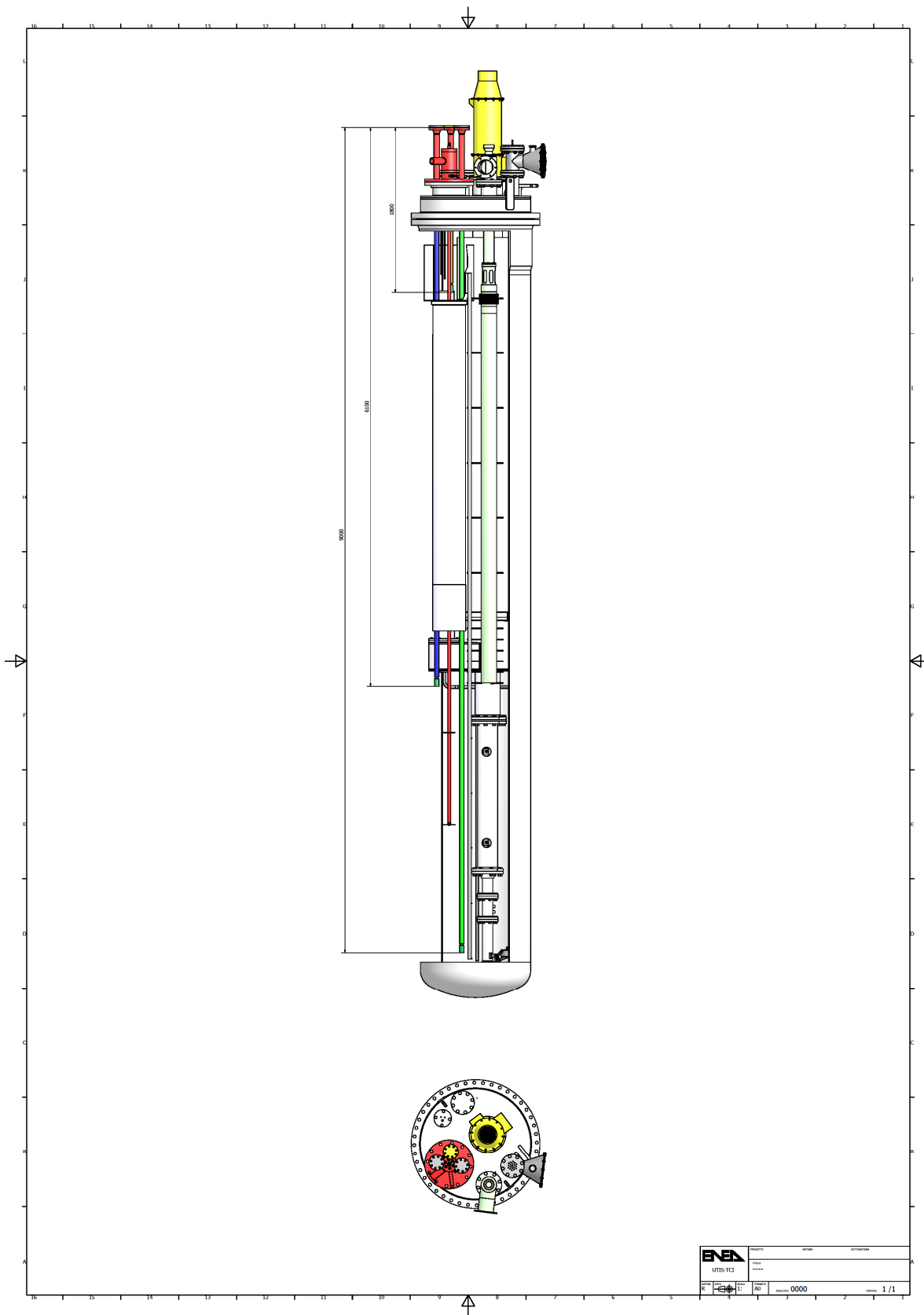

Fig. A. 8 – HERO-CIRCE SGBT inserted in the CIRCE facility.