



Agenzia Nazionale per le Nuove Tecnologie,
l'Energia e lo Sviluppo Economico Sostenibile



Ministero dello Sviluppo Economico

RICERCA DI SISTEMA ELETTRICO

Comparative study of controllers for supervision, control and protection systems in pressurized water reactors of evolutive generation

Stefano Di Gennaro, Bernardino Castillo



COMPARATIVE STUDY OF CONTROLLERS FOR THE SUPERVISION, CONTROL AND PROTECTION
SYSTEMS IN PRESSURIZED WATER REACTORS OF EVOLUTIVE GENERATION

Stefano Di Gennaro, Bernardino Castillo (Università dell'Aquila)

Novembre 2011

Report Ricerca di Sistema Elettrico

Accordo di Programma Ministero dello Sviluppo Economico – ENEA

Area: Governo, gestione e sviluppo del sistema elettrico nazionale

Progetto: Fissione nucleare: metodi di analisi e verifica di progetti nucleari di generazione
evolutiva ad acqua pressurizzata

Responsabile Progetto: Massimo Sepielli, ENEA

Titolo

Comparative study of controllers for the supervision, control and protection systems in pressurized water reactors of evolutive generation

Ente emittente Università di L'Aquila – Centro di Eccellenza DEWS

PAGINA DI GUARDIA

Descrittori
Tipologia del documento:

Collocazione contrattuale: ACCORDO DI PROGRAMMA Ministero dello Sviluppo Economico – ENEA sulla Ricerca di Sistema Elettrico PIANO ANNUALE DI REALIZZAZIONE 2010 Progetto 1.3.2.a: Fissione nucleare: Metodi di analisi e verifica di progetti nucleari di generazione evolutiva ad acqua pressurizzata.

Argomenti trattati: **Controllo dei reattori nucleari, reattori nucleari ad acqua.**

Sommario

Il presente lavoro, sviluppato dal gruppo del Prof. Stefano Di Gennaro del Centro di Eccellenza DEWS dell'Università degli Studi dell'Aquila, si concentra sui sistemi di controllo per i reattori nucleari ad acqua pressurizzata, e si articola secondo tre deliverables.

Il presente documento, dal titolo "Studio comparativo di controllori per la supervisione, il controllo e la protezione in reattori ad acqua pressurizzata di generazione evolutiva", descrive la modellizzazione matematica del circuito primario del reattore allo scopo di individuare le proprietà dei controllori impiegati e valutarne le prestazioni, anche in risposta a perturbazioni esterne o interne.

Negli altri due documenti sono forniti, rispettivamente, una presentazione dettagliata dei sistemi di supervisione, controllo e protezione per il circuito primario di reattori ad acqua in pressione di generazione III/III+, e uno studio delle prestazioni dei sistemi di controllo in presenza di guasti e/o incidenti di riferimento nei reattori evolutivi ad acqua in pressione sulla base di un modello più accurato del pressurizzatore.

Note
Copia n.
In carico a:

2			NOME			
			FIRMA			
1			NOME			
			FIRMA			
0	EMISSIONE		NOME	Mauro CAPPELLI	Emanuele NEGRENTI	Massimo SEPIELLI
			FIRMA			
REV.	DESCRIZIONE	DATA	CONVALIDA	VISTO	APPROVAZIONE	



CENTER OF EXCELLENCE DEWS
DEPARTMENT OF ELECTRICAL AND INFORMATION ENGINEERING

UNIVERSITY OF L'AQUILA, V. G. GRONCHI 18, 67100, L'AQUILA, ITALY

DELIVERABLE 2

Comparative Study of Controllers for the Supervision, Control and Protection Systems in Pressurized Water Reactors of Evolutive Generation

Studio comparativo di controllori per la supervisione, il controllo e la protezione in reattori ad acqua pressurizzata di generazione evolutiva

Authors:
Stefano DI GENNARO and Bernardino
CASTILLO-TOLEDO

Principal Investigator:
Prof. Stefano DI GENNARO

Project PAR 2010
September 30, 2011

Abstract

In this deliverable the supervision, control and protection systems for nuclear reactors of new generation are analyzed. A mathematical model of the primary circuit is presented. This model, in the time domain, is simple enough for the control purposes, but accurate enough to capture the nonlinear, the time-varying, and the switching nature of the plant. On the basis of this control model, a dynamic level controller is determined for the pressurizer water level. Moreover, two dynamics controllers are presented for the pressurizer pressure. These controllers may not use measurements of the pressurizer pressure, relying only on the pressurizer wall temperature measurements. Both the plant model and the controllers are implemented in Simulink, which is a tool for modeling, simulating and analyzing multi-domain dynamic systems. The designed controllers ensure a good performance, also in the presence of uncertainties and disturbances. Their switching nature, reflecting the switching nature of the pressurizer dynamics, ensures better transient behaviors. Hence, they represent an evolution and an improvement with respect to classical PID controllers, usually implemented in standard control actions.

Riassunto

In questo documento vengono analizzati i sistemi di supervisione, controllo e protezione per i reattori nucleari di nuova generazione. Viene presentato un modello matematico del circuito primario. Questo modello, nel dominio del tempo, è abbastanza semplice per le finalità di controllo, ma abbastanza accurato per catturare la natura non-lineare, tempo-variante, e a commutazione dell'impianto. Sulla base di questo modello di controllo, un controllore dinamico del livello dell'acqua nel pressurizzatore. Inoltre, vengono presentati due controllori dinamici per la pressione del pressurizzatore. Questi controllori possono non utilizzare misure della pressione del pressurizzatore, in quanto si basano solo sulle misure della temperatura della parete del pressurizzatore. Sia il modello dell'impianto che i controllori sono implementati in Simulink, che è uno strumento per la modellistica, la simulazione e l'analisi di sistemi dinamici multi-dominio. I controllori progettati garantiscono una buona prestazione, anche in presenza di incertezze e perturbazioni. La loro natura a commutazione, che riflette la natura dinamica a commutazione del pressurizzatore, assicura migliori comportamenti durante i transitori. Di conseguenza, essi rappresentano una evoluzione ed un miglioramento rispetto ai classici controllori PID, di solito implementati in azioni di controllo classici.

1 The control mathematical model

In this section a simple mathematical model of the primary circuit is presented. A mathematical model describes the dynamic behavior of a system, and gives information on the possible behavior one has to expect. These information are fundamental in order to proceed with the design of a control system. In particular, we are here interested in a control mathematical model of a PWR, namely in a model sufficiently simple to be handled with the mathematical tools necessary to ensure certain desired property, such as asymptotic stability. This allows ensuring formally that the behavior of the controlled system is that expected by the design, without the necessity of using intensive simulation verification, at least under the conditions of validity of the model. At the same time, this simple model has to capture the essential aspects of the dynamic behavior of the system. Clearly, the expert of modeling has to choose the best tradeoff between accuracy and simplicity of the model. The design of controllers imply the use of low order lumped (concentrated parameter) models that capture the dynamic behavior of the system. At the same time, it is advantageous if the variables and parameters of this model have precise physical meaning, because such models are clearer for the operating personnel and it is easier to use during its verification.

There are only a few papers in the literature that report simple dynamic models for boiling/pressurized water reactors. A simple model was developed in [8] for the thermal–hydraulics part of a BWR reactor that is used for stability analysis of the reactor under different operating conditions.

A relatively simple dynamic model for PWR, used in a training course for simulation purposes, is reported in [12]. There are also a few simple dynamic models available for the individual operating units in the primary circuit. The modeling and identification of a drum boiler in a boiling water reactor is reported in [1].

In [5], [6], [11] a detailed modeling and model identification procedure was described for a VVER–440 pressurized water reactor (Paks Nuclear Power Plant in Hungary), constructed using a systematic modeling approach. In the following this dynamic model is presented.

1.1 Model assumptions

In order to construct a simple dynamic model of the primary circuit, a systematic modeling procedure can be followed [6]. The basis of this approach is to construct the model based on conservation balances for conserved extensive quantities such as overall mass, internal energy, component masses, number of

neutrons with given energy, etc., supplemented with algebraic constitutive equations.

In order to obtain a low dimensional dynamic model, the simplest possible set of operating units is considered in their simplest functional form. Part of the primary circuit with clear functionality is considered as an operating unit (like the pressurizer). An operating unit may contain more than one physical units (pipes, containers, valves, etc.) but it is then regarded as a primary balance volume over which conservation balances can be constructed. The overall modeling assumptions specify the considered operating units and their general properties.

- (H_1) The set of operating units considered in the simple dynamic model includes the reactor, the water in the primary circuit, the pressurizer and the steam generator.
- (H_2) The dynamic model of the operating units is derived from simplified mass, energy and neutron balances constructed for a single balance volume that corresponds to the individual unit.
- (H_3) The considered controllers in the simplified model are the pressure controller, the level controller of the pressurizer and the power controller of the reactor. All the other controllers (including the level controller in the steam generator, and the controller of the turbines, main circulating pumps and other compressors and valves in the system) are assumed to be ideal, that is, they keep their reference values ideally, without any dynamics or delays.

1.2 Overall system description

Fig. 2 shows the operating units, where the main equipments are the reactor, the steam generator(s), the main circulating pump(s), the pressurizer, and their connections that are taken into account in the simplified model of the primary circuit. The sensors that provide on-line measurements are also indicated in the figure by small full rectangles. The controllers are denoted by double rectangles, their input and output signals are shown by dashed lines.

The steady-state values of the system variables in the normal 100% power operating point are also indicated in Fig. 2. They refer to the primary circuit in Paks nuclear power plant in Hungary [11].

From the viewpoint of their dynamics and the type of their dependence on other operating units, the units of the simplified dynamic model are classified into three groups

1. The reactor which has fast dynamics compared to the other operating units, while its dynamics depend directly only on the temperature of the water in the primary circuit that is neglected;
2. The water in the primary circuit and the steam generator which are the units that transport the energy generated by the reactor to the secondary circuit;
3. The pressurizer that supplies a constant regulated pressure for the primary circuit.

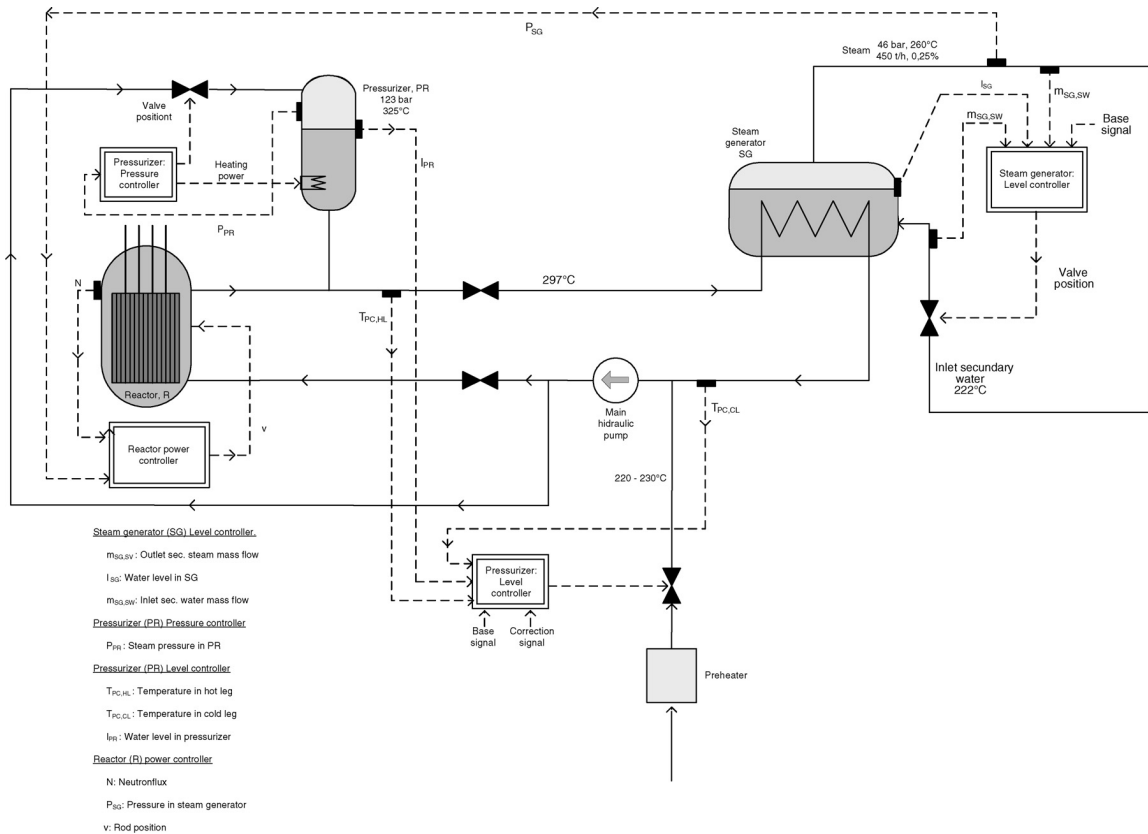

Figure 2: Scheme of the PWR primary circuit

1.3 Simplified dynamic model

The liquid in the primary circuit is circulated at a high speed by powerful circulation pumps, and it is under high pressure in order to avoid boiling. The energy generated in the reactor is transferred by the primary circuit to the liquid in the steam generator making it boiling. The generated secondary circuit vapor is then transferred to the turbines.

The dynamic model of the process has been constructed using a systematic modeling approach proposed in [5], [6], [7], [11].

The model equations of the operating units in the simplified model are derived from dynamic conservation balances that are supplemented with algebraic constitutive equations.

The model of each operating unit in the simplified model is then described in terms of the applied modeling assumptions, its conservation balances and constitutive equations.

In the following the subindices “*r*”, “*pc*”, “*sg*”, “*pr*” refer to the reactor, primary circuit, steam generator, and pressurizer, respectively.

1.3.1 The reactor

The reactor is the main operating unit in the primary circuit that acts primarily as an energy source. The modeling assumptions made to derive a low order dynamic model are the following

- (A_{r,1}) The reactor is regarded as a spatially homogeneous concentrated parameter (lumped) system with only a single balance volume;
- (A_{r,2}) The time-dependent version of the single-group neutron diffusion equation (Kessler, 1983) is applied, that is, we only consider neutrons at the same energy level;
- (A_{r,3}) Only a single type of delayed neutron emitting nuclei is considered with an average β total fraction of delayed neutrons, and an average λ half-life of the delayed neutron emitting nuclei;
- (A_{r,4}) The dependence of the nuclear physical mechanisms on the temperature is neglected; this includes the dependence of the reactivity on the coolant and core temperatures;
- (A_{r,5}) The effect of the control rod position on the reactivity is approximated by a quadratic function;
- (A_{r,6}) A quasi steady-state approximation is used for the concentration of the delayed neutron emitting nuclei;
- (A_{r,7}) The reactor power is assumed to be a homogeneous linear function of the neutron flux;
- (A_{r,8}) The reactor power controller is assumed to operate in its “n” mode providing a simple static feedback from the flux to the control rod position.

From a physical viewpoint, assumption (A_{r,4}) seems to be the most restrictive. The main reason for this assumption is to obtain a dynamic model with the simplest possible algebraic structure and a minimum number of parameters to be estimated, because a more complex model might unnecessarily complicate the process of nonlinear model analysis and controller design. It is expected that this approximation will cause a small difference between the measured and the model predicted neutron flux and primary circuit water temperature values, but this is still an acceptable simplification of reality in the investigated operating region (see also assumption (H₄)).

1.3.1.1 Conservation balances

The differential equations of the reactor model originate from the conservation balances for the concentration of the neutrons (with the neutron flux, N) and the delayed neutron emitting nuclei C

$$\begin{aligned}\dot{N} &= -\frac{\rho(v) + \beta}{\Lambda}N + \lambda C + S \\ \dot{C} &= \frac{\beta}{\Lambda}N - \lambda C\end{aligned}$$

where ρ is the reactivity depending on the control rod position v , Λ is the generation time, β is the total fraction of delayed neutrons, λ is the half-life of the delayed neutron emitting nuclei and S is the flux of a constant neutron source.

These equations can be simplified considering assumption ($A_{r,6}$), so that $\dot{C} \simeq 0$. Then, a constant ratio of N and C is obtained

$$C = \frac{\beta N}{\lambda \Lambda}$$

that can be used to obtain

$$\dot{N} = -\frac{\rho(v)}{\Lambda} N + S.$$

1.3.1.2 Constitutive equations

An algebraic equation is used for the reactor power equation to relate the neutron flux N to the reactor power W_r , which is assumed to be homogeneous linear, as assumed by ($A_{r,7}$)

$$W_r = c_\psi N \quad (1)$$

with c_ψ a constant assumed known.

As far as the effect of the control rod position on the reactivity is concerned, in the operating region it is enough to use a quadratic nonlinear function to model the dependence of the reactivity on the control rod position, i.e.

$$\rho(v) = p_0 + p_1 v + p_2 v^2 \quad (2)$$

where p_0 , p_1 , p_2 are parameters to be estimated. This quadratic form is advantageous from the point of view of parameter estimation because it contains a minimal number of unknown parameters and it is linear in them.

1.3.2 The liquid in the primary circuit

The liquid in the tubes of the primary circuit including the liquid in the reactor, in the primary side tubes of the six steam generators and that in the pressurizer are considered together to form a simple concentrated parameter balance volume for the liquid in the primary circuit.

1.3.2.1 Modeling assumptions

The following simplifying modeling assumptions are considered.

($A_{pc,1}$) There is only a single concentrated parameter balance volume for the total liquid amount in the primary circuit that is assumed to be in liquid phase and assumed to be pure water (the amount of boron is regarded to be negligible);

($A_{pc,2}$) The density φ of the water is assumed to depend on the temperature following a second order polynomial, and its dependence on the pressure is neglected;

($A_{pc,3}$) The specific heat of the water $c_{p,pc}$ is assumed to be a constant value (its dependence on the temperature and pressure is neglected);

($A_{pc,4}$) The effect of the heating in the pressurizer that is applied to regulate the pressure is neglected in the energy balance for the water in the primary circuit;

($A_{pc,5}$) It is assumed that the flow rate in the primary circuit is regulated in such a way that the temperature increase of the water in the reactor is approximately 30° C, thus the temperature difference between the hot leg (hl) and cold leg (cl) temperatures is $T_{pc,hl} - T_{pc,cl} \approx 30^\circ \text{C}$. The average temperature T_{pc} of the water in the primary circuit is then

$$T_{pc} = \frac{T_{pc,hl} + T_{pc,cl}}{2}.$$

1.3.2.2 Conservation balances

The overall mass balance of the water is in the form

$$\dot{M}_{pc} = m_{in} - m_{out}$$

where M_{pc} is the water mass, m_{in} the inlet mass flow rate, and m_{out} is the purge mass flow rate of the primary circuit.

The energy balance for the internal energy U_{pc} takes into account the energy W_r generated by the reactor in unit time, the energy W_{sg} transferred to the secondary circuit through n_{sg} steam generators ($n_{sg} = 6$ at Packs Nuclear Power Plant), the energy effect of the mass inlet and purge (the first and second term) and the energy loss $W_{loss,pc}$ to the environment

$$\dot{U}_{pc} = c_{p,pc}(m_{in}T_{pc,i} - m_{out}T_{pc,cl}) + W_r - n_{sg}W_{sg} - W_{loss,pc}$$

where $c_{p,pc}$ is the specific heat of the water and $T_{pc,i}$ is the inlet water temperature.

1.3.2.3 Constitutive equations

The constitutive equations relate the internal energy U_{pc} to the average temperature T_{pc} of the water in the primary circuit

$$U_{pc} = c_{p,pc}M_{pc}T_{pc}$$

the temperatures in the primary circuit to each other according to assumption ($A_{pc,5}$)

$$T_{pc,hl} = T_{pc} + \Delta \tag{3}$$

$$T_{pc,cl} = T_{pc} - \Delta$$

with $\Delta = 15^\circ\text{C}$, and the energy W_{sg} transferred to the secondary circuit to the average temperature T_{pc} of the water in the primary circuit and to the average secondary circuit liquid temperature T_{sg} of the steam generators

$$W_{sg} = k_{t,sg}(T_{pc} - T_{sg}) \tag{4}$$

where $k_{t,sg}$ is the heat transfer coefficient.

1.3.3 The pressurizer

In the pressurizer there is hot water and steam in the upper part. In the pressurizer, sensors monitor the pressure. If the primary circuit pressure decreases, electric heaters switch on. Due to the heating, more steam will evaporate and this leads to a pressure increase. If the increasing pressure in the pressurizer reaches a certain limit, first the heaters are lowered/turned off, and secondly (relatively) cold water is injected into the tank, if needed, to further reduce the pressure down, into the predefined range.

In the Paks nuclear power plant, the electric heater consists of four heating elements, each with 90 kW of power. Formerly working in an on/off mode, now they can be operated continuously. The hot water temperature is about 325°C,

The inputs of the pressurizer dynamics are the electric heater power and the inflow cold water rate, and the (controlled and measured) output is the pressure in the pressurizer.

The accurate model (high dimensional, with 10–100 state variables) used for the pressurizer is expressed in terms of partial differential equations, discretized in space to have a lumped version, and a complicated dynamic model can be obtained. For the design of the controller, a simplified lumped dynamic model is constructed, that captures the most important dynamics of the pressurizer.

The aim of the pressurizer as an operating unit is twofold

1. It regulates the pressure in the primary circuit by heating its water content by a heating power $W_{heat,pr}$;
2. It serves as an indicator for the primary circuit inventory controller by its water level l_{pr} .

1.3.3.1 Modeling assumptions

The liquid in the pressurizer is part of the primary circuit water. Therefore, these two operating units, and the assumptions imposed on their models are closely related.

- ($A_{pr,1}$) The liquid in the pressurizer is assumed to be pure water (the amount of boron is regarded to be negligible), and it is assumed to be part of the water in the primary circuit. Therefore, no separate mass balance is constructed for the liquid phase. The water mass in the pressurizer is computed as an excess to a nominal mass $M_{pc,0}$ in the primary circuit;
- ($A_{pr,2}$) The density φ of the water is assumed to depend on the temperature following a second order polynomial, and its dependence on the pressure is neglected (see assumption ($A_{pc,2}$));
- ($A_{pr,3}$) The specific heat $c_{p,pr}$ of the water is assumed to be a constant value, and its dependence on the temperature and pressure is neglected;
- ($A_{pr,4}$) The vapor in the pressurizer is assumed to be saturated, and the vapor mass is assumed to be negligible compared to that of the liquid. Therefore, no balances are constructed for the vapor in the pressurizer;

($A_{pr,5}$) The pressure of the saturated vapor is assumed to depend on the temperature T_{pr} of the water in the pressurizer following a known function $p_{*,T}$.

1.3.3.2 Conservation balances

The balances of the internal energies U_{pr} , $U_{pr,wall}$ are derived for the liquid in the pressurizer taking into account the in/out flow mass m_{pr} from the primary circuit, the heat exchange with the wall, and the heating $W_{heat,pr}$ [1], [13], [15]

$$\dot{U}_{pr} = -k_{wall}(T_{pr} - T_{pr,wall}) + W_{heat,pr} + \delta_{pr}c_{p,pc}m_{pr}T_{pc,hl} + (1 - \delta_{pr})c_{p,pr}m_{pr}T_{pr}$$

with $T_{pr,wall}$ the temperature of the wall of the pressurizer, or using (3),

$$\dot{U}_{pr} = -k_{wall}(T_{pr} - T_{pr,wall}) + W_{heat,pr} + \delta_{pr}c_{p,pc}m_{pr}(T_{pc} + \Delta) + (1 - \delta_{pr})c_{p,pr}m_{pr}T_{pr}$$

with δ_{pr} which takes into account the switching dynamics of the pressurizer, and that 1 if $m_{pr} > 0$ and 0 otherwise. Moreover, and considering the heat loss $W_{loss,pr}$

$$\dot{U}_{pr,wall} = k_{wall}(T_{pr} - T_{pr,wall}) - W_{loss,pr}.$$

In these equations $c_{p,wall}$ is the heat capacity of the wall, k_{wall} is the wall heat transfer coefficient.

1.3.3.3 Constitutive equations

Physico-chemical property relations are taken into account to describe the relationships among the internal energy U_{pr} , the pressure and saturated pressure as functions of the temperature T_{pr} in the pressurizer vessel

$$U_{pr} = c_{p,pr}M_{pr}T_{pr}$$

$$U_{pr,wall} = c_{p,wall}T_{pr,wall}$$

$$p_{pr} = p_{*,T}(T_{pr})$$

where $c_{p,pr}$ is the specific heat, M_{pr} is the liquid mass, $c_{p,wall}$ is the heat capacity of the wall, $T_{pr,wall}$ is the pressurizer wall temperature, p_{pr} the pressure. Finally, $p_{*,T}$ is the saturated vapor pressure, that can be taken of the following form [14]

$$p_{*,T}(T) = c_0 - c_1T + c_2T^2 \quad (5)$$

with T the temperature measured in °C, and the pressure obtained in kPa. For the coefficients c_0 , c_1 , c_2 see Table 1.

According to ($A_{pc,2}$), one assumes that the water density φ can be approximated by a quadratic function of the temperature

$$\varphi(T) = c_{\varphi,0} + c_{\varphi,1}T - c_{\varphi,2}T^2 \quad (6)$$

with T the temperature measured in °C, and the density obtained in kg/m³. For the values of the coefficients $c_{\varphi,0}$, $c_{\varphi,1}$, $c_{\varphi,2}$ see Table 1.

As far as the pressurizer water level is concerned, a set of constitutive equations describes the effect of the variation in the primary circuit water mass M_{pc} on the level of the pressurizer l_{pr}

$$\begin{aligned} V_{pc} &= \frac{M_{pc}}{\varphi(T_{pc})}, & V_{pr} &= V_{pc} - V_{pc,0}, & \varphi(T_{pc}) &= c_{\varphi,0} + c_{\varphi,1}T_{pc} - c_{\varphi,2}T_{pc}^2 \\ l_{pr} &= \frac{V_{pr}}{A_{pr}} = \frac{1}{A_{pr}} \left(\frac{M_{pc}}{\varphi(T_{pc})} - V_{pc,0} \right) \end{aligned} \quad (7)$$

where V_{pc} is the overall water volume in the primary circuit, $V_{pc,0}$ is its nominal constant value, $\varphi(T_{pc})$ is the water density given by (6), V_{pr} the pressurizer liquid volume, and A_{pr} is the pressurizer cross-section. According to (A_{pr,1}), the pressurizer water mass is

$$M_{pr} = M_{pc} - \varphi(T_{pc})V_{pc,0} \quad (8)$$

with M_{pc} the overall mass in the primary circuit, and $M_{pc,0} = \varphi(T_{pc})V_{pc,0}$ the nominal mass water in the primary circuit.

The above equation can be used to compute the mass in/outflow from the primary circuit to the pressurizer as follows

$$m_{pr} = \dot{M}_{pr} = \dot{M}_{pc} - \frac{\partial \varphi(T_{pc})}{\partial T_{pc}} \dot{T}_{pc} V_{pc,0} \quad (9)$$

with

$$\frac{\partial \varphi(T_{pc})}{\partial T_{pc}} = c_{\varphi,1} - 2c_{\varphi,2}T_{pc}. \quad (10)$$

1.3.4 The steam generators

The steam generators connect the primary and secondary circuits and transfer the energy generated by the reactor to the secondary steam flow. There are six steam generators in a reactor unit but we model them as a single operating unit.

1.3.4.1 Modeling assumptions

Because the focus of our model is the primary circuit and its controllers, the following simplifying assumptions are made for the steam generators.

(A_{sg,1}) The dynamics of the primary side of the steam generators is very quick compared to that of the secondary side, therefore it is assumed to be in a quasi steady-state and no conservation balances are constructed for it.

(A_{sg,2}) The dynamics of the secondary side vapor phase in the steam generators is also assumed to be very quick compared to that of the secondary side liquid, an equilibrium is assumed between the water and the vapor phases.

(A_{sg,3}) Constant physical properties are assumed for the secondary side of the steam generators.

(A_{sg,4}) All the controllers acting on the secondary side (including the liquid level controller and the secondary steam pressure controller) are assumed to be ideal.

1.3.4.2 Conservation balances

There is only a single balance volume in the n_{sg} steam generators: the liquid of the secondary side, where the overall mass balance is simplified to an algebraic equation, because the inlet secondary water mass flow rate $m_{sg,sw}$ and the outlet secondary steam mass flow rate $m_{sg,ss}$ are kept to be equal by the ideal water level controller of the steam generators

$$m_{sg,sw} = m_{sg,ss} = m_{sg}.$$

Then the balance of the the internal energy U_{sg} for the secondary water in the steam generators is

$$\dot{U}_{sg} = c_{p,sg}^l m_{sg} T_{sg,sw} c_{p,sg}^v m_{sg} T_{sg} - m_{sg} E_{evap,sg} + W_{sg} - W_{loss,sg}$$

where $c_{p,sg}^l$ is the liquid water specific heat, $c_{p,sg}^v$ is the vapor specific heat, $T_{sg,sw}$ is the inlet temperature, T_{sg} is the temperature, $E_{evap,sg}$ is the evaporation energy, $W_{loss,sg}$ is the heat loss, and W_{sg} given by (4).

1.3.4.3 Constitutive equations

The algebraic constitutive equations describe the relationships between physical properties and temperature

$$U_{sg} = c_{p,sg}^l M_{sg} T_{sg}$$

$$p_{sg} = p_{*,T}(T_{sg}) = c_0 - c_1 T_{sg} + c_2 T_{sg}^2$$

where p_{sg} is the pressure, and $p_{*,T}$ is the quadratic function (5).

1.4 The state–space model of the system

The first step is to derive differential equations in the measurable temperatures instead of their related internal energies, using a balance volume of mass M . For, the energy–temperature relationship is used

$$U = c_p M T$$

where c_p is the specific heat. Differentiating the above equation with respect to time, and assuming c_p constant

$$\dot{U} = c_p M \dot{T} + c_p \dot{M} T$$

where \dot{M} can be substituted by the expression of the mass balance for the same balance volume. Following this procedure, the differential equations for the pc , sg and pr temperatures are

$$\dot{T}_{pc} = \frac{1}{c_{p,pc} M_{pc}} \left[c_{p,pc} m_{in} (T_{pc,i} - T_{pc}) + c_{p,pc} m_{out} (T_{pc} - T_{pc,cl}) + W_r - n_{sg} W_{sg} - W_{loss,pc} \right]$$

$$\dot{T}_{sg} = \frac{1}{c_{p,sg}^l M_{sg}} \left[c_{p,sg}^l m_{sg} T_{sg,sw} - c_{p,sg}^v m_{sg} T_{sg} - m_{sg} E_{evap,sg} + W_{sg} - W_{loss,sg} \right]$$

$$\dot{T}_{pr} = \frac{1}{c_{p,pr}M_{pr}} \left[-k_{wall}(T_{pr} - T_{pr,wall}) + W_{heat,pr} + \delta_{pr}(m_{pr}c_{p,pc}(T_{pc} + \Delta) - m_{pr}c_{p,pr}T_{pr}) \right]$$

$$\dot{T}_{pr,wall} = \frac{1}{c_{p,wall}} \left[k_{wall}(T_{pr} - T_{pr,wall}) - W_{loss,pr} \right]$$

Considering the constitutive equations (1), (2), (3), (4), the following set of equations is obtained for the state variables N (the neutron flux, in %), M_{pc} (overall mass in the primary circuit, in kg), T_{pc} (the average temperature of the water in the primary circuit, in °C), T_{sg} (the average secondary circuit liquid temperature, in °C), T_{pr} , $T_{pr,wall}$ (the pressurizer water/wall temperature, in °C)

$$\dot{N} = -\frac{p_0 + p_1v + p_2v^2}{\Lambda}N + S$$

$$\dot{M}_{pc} = m_{in} - m_{out}$$

$$\dot{T}_{pc} = \frac{1}{c_{p,pc}M_{pc}} \left[c_{p,pc}m_{in}(T_{pc,i} - T_{pc}) + c_{p,pc}m_{out}\Delta + c_{\psi}N - n_{sg}k_{t,sg}(T_{pc} - T_{sg}) - W_{loss,pc} \right]$$

$$\dot{T}_{sg} = \frac{1}{c_{p,sg}^l M_{sg}} \left[c_{p,sg}^l m_{sg} T_{sg,sw} - c_{p,sg}^v m_{sg} T_{sg} - m_{sg} E_{evap,sg} + k_{t,sg}(T_{pc} - T_{sg}) - W_{loss,sg} \right]$$

$$\dot{T}_{pr} = \frac{1}{c_{p,pr}M_{pr}} \left[-k_{wall}(T_{pr} - T_{pr,wall}) + W_{heat,pr} + \delta_{pr}(c_{p,pc}m_{pr}(T_{pc} + \Delta) - c_{p,pr}m_{pr}T_{pr}) \right]$$

$$\dot{T}_{pr,wall} = \frac{1}{c_{p,wall}} \left[k_{wall}(T_{pr} - T_{pr,wall}) - W_{loss,pr} \right]$$
(11)

where, from (8), (9), (7), (10)

$$M_{pr} = M_{pc} - \varphi(T_{pc})V_{pc,0}$$

$$m_{pr} = m_{in} - m_{out} - \frac{1}{c_{p,pc}M_{pc}} \frac{\partial \varphi(T_{pc})}{\partial T_{pc}} V_{pc,0} \left[c_{p,pc}m_{in}(T_{pc,i} - T_{pc}) + c_{p,pc}m_{out}\Delta \right. \\ \left. + c_{\psi}N - n_{sg}k_{t,sg}(T_{pc} - T_{sg}) - W_{loss,pc} \right].$$

In (11) v , m_{in} , $W_{heat,pr}$ are the input variables, while $T_{pc,i}$, m_{out} , m_{sg} , M_{sg} , $T_{sg,sw}$ can be considered as disturbances.

The (measurable) outputs of the systems are the reactor power $W_r(N)$, the steam generator pressure p_{sg} (in kPa), the pressurizer pressure p_{pr} (in kPa), the pressurizer water level l_{pr} (in m)

$$W_r(N) = c_{\psi}N$$

$$p_{sg} = p_{*,T}(T_{sg}) = c_0 - c_1T_{sg} + c_2T_{sg}^2$$

$$p_{pr} = p_{*,T}(T_{pr}) = c_0 - c_1T_{pr} + c_2T_{pr}^2$$

$$l_{pr}(M_{pc}, T_{pc}) = \frac{1}{A_{pr}} \left(\frac{M_{pc}}{\varphi(T_{pc})} - V_{pc,0} \right)$$
(12)

with $\varphi(T_{pc})$ as in (7). The model parameters are reported in Table 1.

It is worth noting that equations (11) are hybrid and nonlinear. In fact the equation of T_{pr} contains the switching term δ_{pr} , which is 1 if $m_{pr} > 0$ and 0 if $m_{pr} \leq 0$.

<i>Reactor</i>			
Neutron flux (state variable)	N	99.3	%
Control rod position (input)	v	0	cm
Reactor power (output)	W_r	13.654×10^8	W
Constant in the reactor power equation	c_ψ	13.75×10^6	W/%
Generation time	Λ	10^{-5}	s
Rod reactivity coefficients	p_0	2.85×10^{-4}	m
	p_1	6.08×10^{-5}	m^{-1}
	p_2	1.322×10^{-4}	m^{-2}
Flux of the constant neutron source	S	2830.5	%/s
Total fraction of delayed neutrons	β	0.0064	
Average half-life	λ	0.1	s^{-1}
<i>Primary circuit</i>			
Overall mass in the primary circuit (state)	M_{pc}	2×10^5	kg
Water average temperature (state)	T_{pc}	281.13	$^{\circ}C$
Inlet mass flow rate (input)	m_{in}	1.4222	kg/s
Outlet mass flow rate (disturbance)	m_{out}	2.11	kg/s
Hot leg water temperature	$T_{pc,hl}$	296.13	$^{\circ}C$
Cold leg water temperature	$T_{pc,cl}$	266.13	$^{\circ}C$
Inlet temperature (disturbance)	$T_{pc,i}$	258.85	$^{\circ}C$
Specific heat at 282 $^{\circ}C$	$c_{p,pc}$	5355	J/kg/K
Heat transfer coefficient	$k_{t,sg}$	9.5296×10^6	W/K
Heat loss	$W_{loss,pc}$	2.996×10^7	W
Water nominal volume	$V_{pc,0}$	242	m^3
Water nominal mass	$M_{pc,0}$	2×10^5	kg
Differences $T_{pc,hl} - T_{pc} = T_{pc} - T_{pc,cl}$	Δ	15	$^{\circ}C$
<i>Pressurizer</i>			
Water temperature (state)	T_{pr}	326.57	$^{\circ}C$
Heating power (input)	$W_{heat,pr}$	168	kW
Water level (output)	l_{pr}	4.8	m
Pressure (output)	p_{pr}	123×10^2	kPa
Water specific heat at 325 $^{\circ}$	$c_{p,pr}$	6873.1	J/kg/K
Heat capacity of the wall	$c_{p,wall}$	6.4516×10^7	J/ $^{\circ}C$
Wall heat transfer coefficient	k_{wall}	1.9267×10^8	W/ $^{\circ}C$
Heat loss	$W_{loss,pr}$	1.6823×10^5	W
Water mass	M_{pr}	19400	kg
Vessel cross section	A_{pr}	4.52	m^2
Vessel volume	$V_{pr,vessel}$	44	m^3
<i>Steam generator</i>			
Average secondary circuit liquid temperature (state)	T_{sg}	257.78	$^{\circ}C$
Secondary circ. water specific heat at 260 $^{\circ}$	$c_{p,sg}^l$	3809.9	J/kg/K
Secondary circ. vapor specific heat at 260 $^{\circ}$	$c_{p,sg}^v$	3635.6	J/kg/K
Heat loss	$W_{loss,sg}$	1.8932×10^7	W
Evaporation energy at 260 $^{\circ}$	$E_{evap,sg}$	1.658×10^6	J/kg
Water mass	M_{sg}	34920	kg
Water level	l_{sg}	1.850	m
Steam pressure (output)	p_{sg}	45.3×10^2	kPa
Secondary water mass flow rate (disturbance)	m_{sg}	119.31	kg/s
Secondary circ. steam mass flow rate	$m_{sg,ss}$	119.31	kg/s
Secondary circ. water mass flow rate	$m_{sg,sw}$	119.31	kg/s
Secondary circ. inlet temperature (disturbance)	$T_{sg,sw}$	220.85	$^{\circ}C$
Number of steam generators	n_{sg}	6	
Power transferred to the steam generators	$n_{sg} W_{sg}$	13.351×10^8	W
<i>Functions</i>			
Saturated vapor pressure	$p_{*,T}(T)$		kPa
Coefficients for quadratic approximation	c_0	28884.78	kPa
	c_1	258.01	kPa/ $^{\circ}C$
	c_2	0.63455	kPa/ $^{\circ}C^2$
Water density	$\varphi(T)$		kg/ m^3
Coefficients for quadratic approximation	$c_{\varphi,0}$	581.2	kg/ m^3
	$c_{\varphi,1}$	2.98	kg/ m^3 / $^{\circ}C$
	$c_{\varphi,2}$	0.00848	kg/ m^3 / $^{\circ}C^2$

Table 1: Model parameters

1.4.1 The equilibrium point

To determine the equilibrium pair $x^\circ = (N^\circ \ M_{pc}^\circ \ T_{pc}^\circ \ T_{sg}^\circ \ T_{pr}^\circ \ T_{pr,wall}^\circ)^T$, $u^\circ = (v^\circ \ m_{in}^\circ \ W_{heat,pr}^\circ)^T$, with

$$v^\circ = 0, \quad W_{heat,pr}^\circ = 1.68 \times 10^5$$

it is sufficient to solve for (x°, u°) the equations obtained from (11) with null derivatives and with $x = x^\circ$, $u = u^\circ$. Hence, one obtains

$$\begin{aligned} m_{in}^\circ &= m_{out} \\ N^\circ &= \frac{\Lambda}{p_0} S \\ 0 &= c_{p,pc} m_{in}^\circ (T_{pc,i} - T_{pc}^\circ) + c_{p,pc} m_{out} \Delta + c_\psi N^\circ - n_{sg} k_{t,sg} (T_{pc}^\circ - T_{sg}^\circ) - W_{loss,pc} \\ 0 &= c_{p,sg}^l m_{sg} T_{sg,sw} - c_{p,sg}^v m_{sg} T_{sg}^\circ - m_{sg} E_{evap,sg} + k_{t,sg} (T_{pc}^\circ - T_{sg}^\circ) - W_{loss,sg} \\ 0 &= \frac{1}{M_{pr}^\circ} f_{pr}^\circ \\ 0 &= k_{wall} (T_{pr}^\circ - T_{pr,wall}^\circ) - W_{loss,pr} \end{aligned} \quad (13)$$

where

$$f_{pr}^\circ = -k_{wall} (T_{pr}^\circ - T_{pr,wall}^\circ) + W_{heat,pr}^\circ = -W_{loss,pr} + W_{heat,pr}^\circ, \quad \text{since } m_{pr}^\circ \leq 0$$

$$M_{pr}^\circ = M_{pc}^\circ - \varphi(T_{pc}^\circ) V_{pc,0}$$

$$m_{pr}^\circ = -\frac{1}{c_{p,pc} M_{pc}^\circ} \left. \frac{\partial \varphi(T_{pc})}{\partial T_{pc}} \right|_{T_{pc}^\circ} V_{pc,0} \dot{T}_{pc} \Big|_{x^\circ, u^\circ} = 0, \quad \left. \frac{\partial \varphi(T_{pc})}{\partial T_{pc}} \right|_{T_{pc}^\circ} = c_{\varphi,1} - 2c_{\varphi,2} T_{pc}^\circ$$

Since the first of (13) gives information of m_{in}° only, M_{pc} is free. Moreover, with $m_{in}^\circ = m_{out}$ it results $\dot{M}_{pc} = 0$, therefore $M_{pc}^\circ = M_{pc}(0)$.

From the third and fourth of (13) one gets

$$\begin{pmatrix} T_{pc}^\circ \\ T_{sg}^\circ \end{pmatrix} = \begin{pmatrix} c_{p,pc} m_{in}^\circ + n_{sg} k_{t,sg} & -n_{sg} k_{t,sg} \\ -k_{t,sg} & c_{p,sg}^v m_{sg} + k_{t,sg} \end{pmatrix}^{-1} \begin{pmatrix} c_{p,pc} m_{in}^\circ T_{pc,i} + c_{p,pc} m_{out} \Delta + c_\psi N^\circ - W_{loss,pc} \\ m_{sg} (c_{p,sg}^l T_{sg,sw} - E_{evap,sg}) - W_{loss,sg} \end{pmatrix}.$$

Furthermore, from the fifth of (13), in which M_{pr}° is a constant, one gets

$$W_{heat,pr}^\circ = W_{loss,pr}$$

but has no constraint on T_{pr}° , which is therefore

$$T_{pr}^\circ = T_{pr}(0).$$

Finally, from the last of (13)

$$T_{pr,wall}^\circ = T_{pr}^\circ - \frac{W_{loss,pr}}{k_{wall}}.$$

1.5 The control problem

The neutron flux and the heating in the pressurizer are usually controlled separately. This is quite valid in the neighborhood of the prescribed steady states, but during large load changes, the temperature in the pressurizer usually slightly goes out of the required optimal operating interval. Therefore, the goal of the controller design is to obtain such a controller that, first of all, keeps all the predefined hard constraints for the state and input variables and that, secondly, produces a satisfactorily quick load change transient.

Classical control objectives when steering the system from one operating point to another are

1. small settling time for the neutron flux;
2. small temperature changes in the pressurizer during transients (for instance at most 1 K);
3. hard, physical constraints for the control inputs v , $W_{heat,pr}$, due to the limited heating energy at the pressurizer.

As far as the the reactor power controller is concerned, we can distinguish two operating modes

1. “N mode”, when the value of the neutron flux is fed back to adjust the rod position to keep the neutron flux constant or to follow a reference trajectory;
2. “T mode”, when the pressure of the steam in the secondary circuit generated by the steam generator is used for the feedback.

The “N mode” of the reactor power controller can be considered with a static state feedback and with a constraint on the control rod velocity. The control input is the rod position v , even if one can consider $\eta = (p_0 + p_1v + p_2v^2)N$ as control input, since the polynomial $\rho(v) = p_0 + p_1v + p_2v^2$ is monotonously increasing, and hence invertible

$$v = \rho^{-1}(\eta/N).$$

The constraints prescribed for v can be transformed into equivalent constraints prescribed for v can be transformed into equivalent constraints for η as follows

$$v_{\min} \leq v \leq v_{\max} \quad \Leftrightarrow \quad N_{\min}\rho(v_{\min}) \leq \eta \leq N_{\min}\rho(v_{\max})$$

where $\rho(v_{\min}) < 0 < \rho(v_{\max})$, and N_{\min} is a physical limit for which $0 < N_{\min} \leq N$ always holds.

The aim of the present section is not to design a reactor power controller. The aim is rather to design a control law to control the pressurizer behavior. More precisely, the control objective is to design dynamic controllers for

1. the pressurizer level control;
2. the pressurizer pressure control;

namely controllers for the water level and pressure in the pressurizer. These controllers are also reported in [2], [3], [4]. One important hypothesis is that neither the temperature T_{pr} nor the pressure p_{pr} are available for measuring. In fact, the measured temperature is the that of the wall of the pressurizer $T_{pr,wall}$. Moreover, also p_{pr} will be supposed not measured, since it is clear that if p_{pr} is known, T_{pr} can be obtained from (12).

1.5.1 Inventory controller for the primary circuit

1.5.1.1 Pressurizer level control system

The pressurizer level control system functions to maintain the proper water inventory in the primary circuit. This inventory is maintained by controlling the balance between water leaving and entering the system.

The water leaving the system, via piping and valves to the letdown condenser, and then to the purification and volume control system. This operation is called coolant “bleeding” or “letdown”. The water enters the system via charging pumps, also called feed pumps.

Since letdown flow is a fixed amount, the balance is maintained by varying the charging flow, by varying the position of charging flow control valves in the discharge header of the charging pumps, usually by using PI controllers.

1.5.1.2 The design of a nonlinear controller

The inventory controller of the primary circuit aims at maintaining an adequate level of water in the pressurizer.

It uses the measured state variables to keep the value of l_{pr} to its reference $l_{pr,ref}$. Deriving l_{pr} in (12) one obtains

$$\dot{l}_{pr} = \frac{1}{A_{pr}} \left[\left(\frac{1}{\varphi(T_{pc})} - \frac{T_{pc,i} - T_{pc}}{\varphi^2(T_{pc})} \frac{\partial \varphi(T_{pc})}{\partial T_{pc}} \right) m_{in} - \frac{m_{out}}{\varphi(T_{pc})} - \frac{1}{c_{p,pc}} \frac{1}{\varphi^2(T_{pc})} \frac{\partial \varphi(T_{pc})}{\partial T_{pc}} \left(c_{p,pc} m_{out} \Delta + c_{\psi} N - n_{sg} k_{t,sg} (T_{pc} - T_{sg}) - W_{loss,pc} \right) \right]$$

with $\varphi(T_{pc})$ as in (7), and $\frac{\partial \varphi(T_{pc})}{\partial T_{pc}}$ as in (10).

Considering the nominal values of the disturbances

$$\Delta^{\circ}, \quad T_{pc,i}^{\circ}, \quad m_{out}^{\circ}, \quad W_{loss,pc}^{\circ} \quad (14)$$

and the variations

$$\delta_{\Delta} = \Delta - \Delta^{\circ}, \quad \delta_{T_{pc,i}} = T_{pc,i} - T_{pc,i}^{\circ}, \quad \delta_{m_{out}} = m_{out} - m_{out}^{\circ}, \quad \delta_{W_{loss,pc}} = W_{loss,pc} - W_{loss,pc}^{\circ} \quad (15)$$

one gets

$$\dot{l}_{pr} = \frac{1}{\varphi^2(T_{pc})} \frac{1}{A_{pr}} \left[\left(\varphi(T_{pc}) - (T_{pc,i}^{\circ} - T_{pc}) \frac{\partial \varphi(T_{pc})}{\partial T_{pc}} \right) m_{in} \right]$$

$$\begin{aligned}
& -m_{out}^{\circ}\varphi(T_{pc}) - \frac{1}{c_{p,pc}} \frac{\partial\varphi(T_{pc})}{\partial T_{pc}} (c_{p,pc}m_{out}^{\circ}\Delta^{\circ} + c_{\psi}N - n_{sg}k_{t,sg}(T_{pc} - T_{sg}) - W_{loss,pc}^{\circ}) \\
& - \frac{\partial\varphi(T_{pc})}{\partial T_{pc}} m_{in}\delta_{T_{pc,i}} - \varphi(T_{pc})\delta_{m_{out}} - \frac{\partial\varphi(T_{pc})}{\partial T_{pc}} (m_{out}^{\circ}\delta_{\Delta} + \Delta^{\circ}\delta_{m_{out}} + \delta_{m_{out}}\delta_{\Delta}) \\
& + \frac{1}{c_{p,pc}} \frac{\partial\varphi(T_{pc})}{\partial T_{pc}} \delta_{W_{loss,pc}} \Big].
\end{aligned}$$

Therefore, one determines the control law maintaining l_{pr} to the desired reference

$$\begin{aligned}
m_{in} = & \frac{A_{pr}}{\varphi(T_{pc}) - (T_{pc,i}^{\circ} - T_{pc}) \frac{\partial\varphi(T_{pc})}{\partial T_{pc}}} \left[\left(\dot{l}_{pr,ref} - k_p(l_{pr} - l_{pr,ref}) - k_i \int_0^t (l_{pr}(\tau) - l_{pr,ref}(\tau)) d\tau \right) \varphi^2(T_{pc}) \right. \\
& \left. + m_{out}^{\circ}\varphi(T_{pc}) + \frac{1}{c_{p,pc}} \frac{\partial\varphi(T_{pc})}{\partial T_{pc}} (c_{p,pc}m_{out}^{\circ}\Delta^{\circ} + c_{\psi}N - n_{sg}k_{t,sg}(T_{pc} - T_{sg}) - W_{loss,pc}^{\circ}) \right]
\end{aligned}$$

such that

$$\begin{aligned}
\dot{e}_{l_{pr}} &= e_{l_{pr}} \\
\dot{e}_{l_{pr}} + k_p e_{l_{pr}} + k_i I_{e_{l_{pr}}} &= \frac{1}{\varphi^2(T_{pc})} \frac{1}{A_{pr}} \left[- \frac{\partial\varphi(T_{pc})}{\partial T_{pc}} m_{in}\delta_{T_{pc,i}} - \varphi(T_{pc})\delta_{m_{out}} \right. \\
& \left. - \frac{\partial\varphi(T_{pc})}{\partial T_{pc}} (m_{out}^{\circ}\delta_{\Delta} + \Delta^{\circ}\delta_{m_{out}} + \delta_{m_{out}}\delta_{\Delta}) + \frac{1}{c_{p,pc}} \frac{\partial\varphi(T_{pc})}{\partial T_{pc}} \delta_{W_{loss,pc}} \right].
\end{aligned}$$

where $e_{l_{pr}} = l_{pr} - l_{pr,ref}$ and $k_p, k_i > 0$, or equivalently

$$\begin{pmatrix} \dot{e}_{l_{pr}} \\ e_{l_{pr}} \end{pmatrix} = A \begin{pmatrix} I_{e_{l_{pr}}} \\ e_{l_{pr}} \end{pmatrix} + \Psi \delta \quad (16)$$

with

$$A = \begin{pmatrix} 0 & 1 \\ -k_i & -k_p \end{pmatrix}, \quad \delta = \begin{pmatrix} \delta_{T_{pc,i}} \\ \delta_{m_{out}} \\ \delta_{\Delta} \\ \delta_{W_{loss,pc}} \\ \delta_{m_{out}}\delta_{\Delta} \end{pmatrix}$$

and

$$\Psi = \frac{1}{\varphi^2(T_{pc})} \frac{1}{A_{pr}} \begin{pmatrix} 0 & 0 & 0 & 0 & 0 \\ -\frac{\partial\varphi(T_{pc})}{\partial T_{pc}} m_{in} & -\varphi(T_{pc}) - \frac{\partial\varphi(T_{pc})}{\partial T_{pc}} \Delta^{\circ} & -\frac{\partial\varphi(T_{pc})}{\partial T_{pc}} m_{out}^{\circ} & \frac{1}{c_{p,pc}} \frac{\partial\varphi(T_{pc})}{\partial T_{pc}} & -\frac{\partial\varphi(T_{pc})}{\partial T_{pc}} \end{pmatrix}.$$

If the variations are zero, i.e. the disturbances are the nominal ones, l_{pr} tends exponentially to $l_{pr,ref}$. Otherwise, it is easy to check that $e_{l_{pr}}, \dot{e}_{l_{pr}}$ tend to a neighborhood of the origin (practical exponential stability), of radius

$$\mu = \frac{\kappa}{\vartheta \lambda_{\min}^Q} \|P\| \delta_{\max}$$

where $\kappa = \max_t \|\Psi\|$, P solution of $PA + A^T P = -2Q$ for a fixed $Q = Q^T > 0$, λ_{\min}^Q the minimum eigenvalue of Q , $\vartheta \in (0, 1)$, $\|\delta\| \leq \delta_{\max}$. This can be checked considering the Lyapunov function

$$V = \frac{1}{2} \begin{pmatrix} I_{e_{l_{pr}}} \\ e_{l_{pr}} \end{pmatrix}^T P \begin{pmatrix} I_{e_{l_{pr}}} \\ e_{l_{pr}} \end{pmatrix}, \quad P = P^T > 0.$$

Deriving V along the trajectories of $e_{l_{pr}}$, according to (16) one works out

$$\dot{V} = - \begin{pmatrix} I_{e_{l_{pr}}} \\ e_{l_{pr}} \end{pmatrix}^T \mathcal{Q} \begin{pmatrix} I_{e_{l_{pr}}} \\ e_{l_{pr}} \end{pmatrix} + \begin{pmatrix} I_{e_{l_{pr}}} \\ e_{l_{pr}} \end{pmatrix}^T P \Psi \delta \leq -(1 - \vartheta) \lambda_{\min}^{\mathcal{Q}} \left\| \begin{pmatrix} I_{e_{l_{pr}}} \\ e_{l_{pr}} \end{pmatrix} \right\|^2$$

for

$$\left\| \begin{pmatrix} I_{e_{l_{pr}}} \\ e_{l_{pr}} \end{pmatrix} \right\| \geq \mu.$$

which proves the practical exponential stability of the error level [9].

Hence, the inventory control for the primary circuit is

$$\begin{aligned} \dot{l}_{e_{l_{pr}}} &= l_{pr} - l_{pr,\text{ref}} \\ m_{in} &= \frac{A_{pr}}{\varphi(T_{pc}) - (T_{pc,i}^{\circ} - T_{pc}) \frac{\partial \varphi(T_{pc})}{\partial T_{pc}}} \left[(l_{pr,\text{ref}} - k_p(l_{pr} - l_{pr,\text{ref}}) - k_i I_{e_{l_{pr}}}) \varphi^2(T_{pc}) \right. \\ &\quad \left. + m_{out}^{\circ} \varphi(T_{pc}) + \frac{1}{c_{p,pc}} \frac{\partial \varphi(T_{pc})}{\partial T_{pc}} (c_{p,pc} m_{out}^{\circ} \Delta^{\circ} + c_{\psi} N - n_{sg} k_{t,sg} (T_{pc} - T_{sg}) - W_{loss,pc}^{\circ}) \right]. \end{aligned} \quad (17)$$

It is worth considering the aspect of the reference generation. The signal $l_{pr,\text{ref}}$ is usually proportional to a mean value between the cold and the hot leg temperatures, with a drift to give a proper value [10]

$$l_{pr,\text{ref}} = c_{r,1}(T_{pc,cl} + T_{pc,hl}) - c_{r,2}.$$

Using $(A_{pc,5})$, from (3) one gets

$$l_{pr,\text{ref}} = 2c_{r,1}T_{pc} - c_{r,2}$$

so that

$$\dot{l}_{pr,\text{ref}} = \frac{2c_{r,1}}{c_{p,pc}M_{pc}} \left[c_{p,pc}m_{in}(T_{pc,i} - T_{pc}) + c_{p,pc}m_{out}\Delta + c_{\psi}N - n_{sg}k_{t,sg}(T_{pc} - T_{sg}) - W_{loss,pc} \right].$$

Referring to a nominal condition given by (14), the implemented derivative is

$$\dot{l}_{pr,\text{ref}} = \frac{2c_{r,1}}{c_{p,pc}M_{pc}} \left[c_{p,pc}m_{in}(T_{pc,i}^{\circ} - T_{pc}) + c_{p,pc}m_{out}^{\circ}\Delta^{\circ} + c_{\psi}N - n_{sg}k_{t,sg}(T_{pc} - T_{sg}) - W_{loss,pc}^{\circ} \right]$$

which, substituted in (17) gives the implementable control law for the inventory control of the primary circuit

$$\begin{aligned} \dot{l}_{e_{l_{pr}}} &= l_{pr} - l_{pr,\text{ref}} \\ m_{in} &= \frac{A_{pr}}{\psi(M_{pc}, T_{pc})} \left[- (k_p(l_{pr} - l_{pr,\text{ref}}) + k_i I_{e_{l_{pr}}}) \varphi^2(T_{pc}) + m_{out}^{\circ} \varphi(T_{pc}) \right. \\ &\quad \left. + \frac{1}{c_{p,pc}} \left(\frac{2c_{r,1}}{M_{pc}} \varphi^2(T_{pc}) + \frac{\partial \varphi(T_{pc})}{\partial T_{pc}} \right) (c_{p,pc} m_{out}^{\circ} \Delta^{\circ} + c_{\psi} N - n_{sg} k_{t,sg} (T_{pc} - T_{sg}) - W_{loss,pc}^{\circ}) \right] \end{aligned} \quad (18)$$

with

$$\psi(M_{pc}, T_{pc}) = \varphi(T_{pc}) - (T_{pc,i}^{\circ} - T_{pc}) \frac{\partial \varphi(T_{pc})}{\partial T_{pc}} - \frac{2c_{r,1}A_{pr}}{M_{pc}} (T_{pc,i}^{\circ} - T_{pc}) \varphi^2(T_{pc})$$

and $\varphi(T_{pc})$, $\frac{\partial \varphi(T_{pc})}{\partial T_{pc}}$ as in (7), (10).

1.5.2 Pressurizer pressure controller

1.5.2.1 The control system

The pressurizer pressure control system controls the pressure of the coolant of the primary circuit at a fixed set point. Among the actuators, the control system includes electric heaters, spray valves, and relief valves actuated at the proper times by a pressure controller. This controller is usually a simple PID controller.

The pressurizer heaters are divided into two groups, consisting of one bank of variable heaters, and several banks of backup on–off heaters. The variable heaters are operated by varying the applied voltage, which determines their heat output over a fixed pressure range. These heaters maintain the equilibrium heat balance in the pressurizer during steady state conditions.

If system pressure decreases significantly from the set point, the variable heaters would provide maximum heat output and, in addition, the backup heaters would be turned on.

If system pressure increases above normal, all the heaters would be turned off and spray valves would be opened, proportionally over a fixed pressure range, to admit cooler water to condense steam, thereby returning system pressure to normal.

For very large pressure transients, on the pressurizer there are pressure relief valves which will open in the event that the spray valves are not capable of controlling the pressure surge. The pressure relief valve operates as an on/off control action.

In the event that a transient occurs that exceeds the capability of the pressure relief valves, on the pressurizer there are some spring loaded safety valves as a final means of protecting the integrity of the reactor coolant system. The safety valves begin to open at a given pressure value and reach the fully opened position when the pressure increases by a given higher pressure value.

The aim of this section is to propose some nonlinear dynamic controllers ensuring a better performance, and based on the measured variables. In particular, the pressurizer temperature T_{pr} will be considered not measured, since the sensors placed on the pressurizer measure the wall temperature $T_{pr,wall}$. Hence, an observer is necessary to reconstruct T_{pr} .

It is worth noting that, in the controllers that are proposed hereinafter, only the observer of T_{pr} will be designed, and no full–order–like observers will be considered, namely the estimation of $T_{pr,wall}$ will be not considered. Simple modifications can be done to obtain such full–order–like observers.

1.5.2.2 The design of a nonlinear controller

A first nonlinear dynamic controller will be designed with the same approach used in [13], where the pressurizer pressure reference $p_{pr,ref}$ is transformed into a pressurizer water reference temperature $T_{pr,ref}$. This is done inverting the relation obtained from (12)

$$p_{pr,ref} = c_0 - c_1 T_{pr,ref} + c_2 T_{pr,ref}^2 \quad (19)$$

and noting that (19) can be uniquely inverted about the operating point of pressurizer temperature

$$T_{pr,ref} = \frac{c_1 + \sqrt{c_1^2 - 4c_2(c_0 - p_{pr,ref})}}{2c_2} \quad (20)$$

with

$$\dot{T}_{pr,ref} = \frac{2\dot{p}_{pr,ref}}{\sqrt{c_1^2 - 4c_2(c_0 - p_{pr,ref})}}.$$

The pressurizer pressure controller can be determined considering the temperature dynamics when $m_{pr} > 0$, see (11)

$$\begin{aligned} \dot{T}_{pr} &= -\frac{k_{wall}}{c_{p,pr}M_{pr}}(T_{pr} - T_{pr,wall}) + \frac{1}{c_{p,pr}M_{pr}}W_{heat,pr} + \delta_{pr}\left(\frac{c_{p,pc}m_{pr}}{c_{p,pr}M_{pr}}(T_{pc} + \Delta) - \frac{m_{pr}}{M_{pr}}T_{pr}\right) \\ \dot{T}_{pr,wall} &= \frac{k_{wall}}{c_{p,wall}}(T_{pr} - T_{pr,wall}) - \frac{1}{c_{p,wall}}W_{loss,pr} \end{aligned} \quad (21)$$

where

$$\begin{aligned} M_{pr} &= M_{pc} - \varphi(T_{pc})V_{pc,0} \\ m_{pr} &= m_{in} - m_{out} - \frac{1}{c_{p,pc}M_{pc}}\frac{\partial\varphi(T_{pc})}{\partial T_{pc}}V_{pc,0}\left[c_{p,pc}m_{in}(T_{pc,i} - T_{pc}) + c_{p,pc}m_{out}\Delta \right. \\ &\quad \left. + c_{\psi}N - n_{sg}k_{t,sg}(T_{pc} - T_{sg}) - W_{loss,pc}\right] \end{aligned} \quad (22)$$

and where δ_{pr} is a flag that takes into account the switching dynamics of the pressurizer and that 1 if $m_{pr} > 0$ and 0 otherwise.

Equations (21) are switching, due to the pressurizer switching behavior, and time varying, due to M_{pr} , m_{pr} which depend on N , M_{pc} , T_{pc} , T_{sg} (state variables of the whole dynamics (11)) and the input m_{in} , and are subject to the disturbance signals $W_{loss,pr}$ and $T_{pc} + \Delta$ (directly), $T_{pc,i}$, m_{out} , and $W_{loss,pc}$ (indirectly).

Let us consider the nominal values of the disturbances $W_{loss,pr}^{\circ}$ and (14), and the variations $\delta_{W_{loss,pr}} = W_{loss,pr} - W_{loss,pr}^{\circ}$ and (15). We consider also

$$\begin{aligned} m_{pr} &= m_{pr}^{\circ} + \delta_{m_{pr}} \\ m_{pr}^{\circ} &= m_{in} - m_{out}^{\circ} - \frac{1}{c_{p,pc}M_{pc}}\frac{\partial\varphi(T_{pc})}{\partial T_{pc}}V_{pc,0}\left[c_{p,pc}m_{in}(T_{pc,i}^{\circ} - T_{pc}) + c_{p,pc}m_{out}^{\circ}\Delta^{\circ} \right. \\ &\quad \left. + c_{\psi}N - n_{sg}k_{t,sg}(T_{pc} - T_{sg}) - W_{loss,pc}^{\circ}\right] \\ \delta_{m_{pr}} &= -\delta_{m_{out}} - \frac{1}{c_{p,pc}M_{pc}}\frac{\partial\varphi(T_{pc})}{\partial T_{pc}}V_{pc,0}\left[c_{p,pc}m_{in}\delta_{T_{pc,i}} + c_{p,pc}(\Delta\delta_{m_{out}} + m_{out}^{\circ}\delta_{\Delta}) - \delta_{W_{loss,pc}}\right] \end{aligned} \quad (23)$$

where one has considered that

$$m_{out}\Delta - m_{out}^{\circ}\Delta^{\circ} = \Delta\delta_{m_{out}} + m_{out}^{\circ}\delta_{\Delta}.$$

Note that m_{pr}° is still time-varying.

In order to determine a controller which depends on the (measured) temperature $T_{pr,wall}$, but not on the (unmeasured) temperature T_{pr} , one can proceed as follows. One introduces the pressurizer wall temperature nominal reference as solution of the following equation

$$\dot{T}_{pr,wall,ref} = \frac{k_{wall}}{c_{p,wall}}(T_{pr,ref} - T_{pr,wall,ref}) - \frac{1}{c_{p,wall}}W_{loss,pr}^\circ$$

with $T_{pr,wall,ref}(0) = T_{pr,ref}(0) - W_{loss,pr}^\circ/k_{wall}$. Moreover, one calculates the reference control $W_{heat,pr,ref}$ on the basis of the nominal reference temperature behavior

$$\begin{aligned} \dot{T}_{pr,ref} = & -\frac{k_{wall}}{c_{p,pr}M_{pr}}(T_{pr,ref} - T_{pr,wall,ref}) + \frac{1}{c_{p,pr}M_{pr}}W_{heat,pr,ref} \\ & + \delta_{pr}\left(\frac{c_{p,pc}m_{pr}^\circ}{c_{p,pr}M_{pr}}(T_{pc} + \Delta^\circ) - \frac{m_{pr}^\circ}{M_{pr}}T_{pr,ref}\right) \end{aligned}$$

obtaining

$$\begin{aligned} W_{heat,pr,ref} = & c_{p,pr}M_{pr}\left[\dot{T}_{pr,ref} + \frac{k_{wall}}{c_{p,pr}M_{pr}}(T_{pr,ref} - T_{pr,wall,ref}) \right. \\ & \left. - \delta_{pr}\left(\frac{c_{p,pc}m_{pr}^\circ}{c_{p,pr}M_{pr}}(T_{pc} + \Delta^\circ) - \frac{m_{pr}^\circ}{M_{pr}}T_{pr,ref}\right)\right] \end{aligned} \quad (24)$$

with M_{pr} as in (22). In terms of the error variables and the error input

$$e_{T_{pr}} = T_{pr} - T_{pr,ref}$$

$$e_{T_{pr,wall}} = T_{pr,wall} - T_{pr,wall,ref}$$

$$u_{e,W} = W_{heat,pr} - W_{heat,pr,ref}$$

equations (21) can be rewritten as

$$\begin{aligned} \dot{e}_{T_{pr}} = & -\frac{k_{wall}}{c_{p,pr}M_{pr}}(e_{T_{pr}} - e_{T_{pr,wall}}) + \frac{1}{c_{p,pr}M_{pr}}u_{e,W} \\ & + \delta_{pr}\left(\frac{c_{p,pc}m_{pr}^\circ}{c_{p,pr}M_{pr}}\delta_\Delta + \frac{1}{M_{pr}}\left(\frac{c_{p,pc}}{c_{p,pr}}(T_{pc} + \Delta) - T_{pr}\right)\delta_{m_{pr}} - \frac{m_{pr}^\circ}{M_{pr}}e_{T_{pr}}\right) \\ \dot{e}_{T_{pr,wall}} = & \frac{k_{wall}}{c_{p,wall}}(e_{T_{pr}} - e_{T_{pr,wall}}) - \frac{1}{c_{p,wall}}\delta W_{loss,pr}. \end{aligned}$$

The control $u_{e,W}$ will be designed making use of the Lyapunov theory and the Lyapunov function

$$V = \frac{1}{2}e_{T_{pr}}^2 + \frac{1}{2}e_{T_{pr,wall}}^2 + \frac{1}{2}z_{T_{pr}}^2$$

where the estimation error $z_{T_{pr}} = T_{pr} - \hat{T}_{pr}$ is considered. The dynamics of the estimate \hat{T}_{pr} of T_{pr} are chosen as follows

$$\dot{\hat{T}}_{pr} = -\frac{k_{wall}}{c_{p,pr}M_{pr}}(\hat{T}_{pr} - T_{pr,wall}) + \frac{1}{c_{p,pr}M_{pr}}W_{heat,pr} + \delta_{pr}\left(\frac{c_{p,pc}m_{pr}^\circ}{c_{p,pr}M_{pr}}(T_{pc} + \Delta^\circ) - \frac{m_{pr}^\circ}{M_{pr}}\hat{T}_{pr}\right)$$

giving the error dynamics

$$\dot{z}_{T_{pr}} = -\frac{k_{wall}}{c_{p,pr}M_{pr}}z_{T_{pr}} + \delta_{pr}\left(\frac{c_{p,pc}m_{pr}}{c_{p,pr}M_{pr}}\delta_{\Delta} - \frac{T_{pr}}{M_{pr}}\delta_{m_{pr}} - \frac{m_{pr}^{\circ}}{M_{pr}}z_{T_{pr}}\right). \quad (25)$$

Deriving V , one gets

$$\begin{aligned} \dot{V} = & -\frac{k_{wall}}{c_{p,pr}M_{pr}}e_{T_{pr}}^2 - \frac{k_{wall}}{c_{p,wall}}e_{T_{pr,wall}}^2 - \frac{k_{wall}}{c_{p,pr}M_{pr}}z_{T_{pr}}^2 \\ & + \left(\frac{k_{wall}}{c_{p,pr}M_{pr}} + \frac{k_{wall}}{c_{p,wall}}\right)e_{T_{pr}}e_{T_{pr,wall}} + \frac{1}{c_{p,pr}M_{pr}}e_{T_{pr}}u_{e,W} \\ & + \delta_{pr}\left[-\frac{m_{pr}^{\circ}}{M_{pr}}e_{T_{pr}}^2 + \frac{c_{p,pc}m_{pr}^{\circ}}{c_{p,pr}M_{pr}}e_{T_{pr}}\delta_{\Delta} + \frac{1}{M_{pr}}\left(\frac{c_{p,pc}}{c_{p,pr}}(T_{pc} + \Delta) - T_{pr}\right)e_{T_{pr}}\delta_{m_{pr}} \right. \\ & \left. - \frac{1}{c_{p,wall}}e_{T_{pr,wall}}\delta_{W_{loss,pr}} - \frac{m_{pr}^{\circ}}{M_{pr}}z_{T_{pr}}^2 - \frac{T_{pr}}{M_{pr}}z_{T_{pr}}\delta_{m_{pr}} + \frac{c_{p,pc}m_{pr}}{c_{p,pr}M_{pr}}z_{T_{pr}}\delta_{\Delta}\right] \end{aligned}$$

and setting

$$u_{e,W} = -\left(k_{wall} + c_{p,pr}M_{pr}\frac{k_{wall}}{c_{p,wall}}\right)e_{T_{pr,wall}}$$

one obtains

$$\begin{aligned} \dot{V} \leq & -\frac{k_{wall}}{c_{p,pr}M_{pr,max}}e_{T_{pr}}^2 - \frac{k_{wall}}{c_{p,wall}}e_{T_{pr,wall}}^2 - \frac{k_{wall}}{c_{p,pr}M_{pr,max}}z_{T_{pr}}^2 \\ & + \delta_{pr}\left[-\frac{m_{pr,min}^{\circ}}{M_{pr,max}}e_{T_{pr}}^2 + \frac{c_{p,pc}m_{pr,max}^{\circ}}{c_{p,pr}M_{pr,min}}|e_{T_{pr}}|\delta_{\Delta}\right] \\ & + \frac{1}{M_{pr,min}}\left|\frac{c_{p,pc}}{c_{p,pr}}(T_{pc,max} + \Delta_{max}) + T_{pr,max}\right||e_{T_{pr}}|\delta_{m_{pr}} + \frac{1}{c_{p,wall}}|e_{T_{pr,wall}}|\delta_{W_{loss,pr}}| \\ & - \frac{m_{pr,min}^{\circ}}{M_{pr,max}}z_{T_{pr}}^2 + \frac{T_{pr,max}}{M_{pr,min}}|z_{T_{pr}}|\delta_{m_{pr}} + \frac{c_{p,pc}m_{pr,max}}{c_{p,pr}M_{pr,min}}|z_{T_{pr}}|\delta_{\Delta}\right] \end{aligned}$$

where $T_{pr,max}$, $T_{pc,max}$, Δ_{max} are the maximal values of T_{pr} , T_{pc} , Δ , and

$$\begin{aligned} M_{pr,min} &= \min_{M_{pc}, T_{pc}} M_{pr} \\ M_{pr,max} &= \max_{M_{pc}, T_{pc}} M_{pr} \\ m_{pr,min}^{\circ} &= \min_{T_{pc}, M_{pc}} m_{pr}^{\circ} \\ &\quad m_{out}^{\circ}, T_{pc,i}^{\circ}, \Delta^{\circ}, W_{loss,pc}^{\circ} \\ m_{pr,max}^{\circ} &= \max_{T_{pc}, M_{pc}} m_{pr}^{\circ} \\ &\quad m_{out}^{\circ}, T_{pc,i}^{\circ}, \Delta^{\circ}, W_{loss,pc}^{\circ} \end{aligned} \quad (26)$$

Therefore, the dynamic controller

$$\begin{aligned}
\dot{\hat{T}}_{pr} &= -\frac{k_{wall}}{c_{p,pr}M_{pr}}(\hat{T}_{pr} - T_{pr,wall}) + \frac{1}{c_{p,pr}M_{pr}}W_{heat,pr} + \delta_{pr}\left(\frac{c_{p,pc}m_{pr}^{\circ}}{c_{p,pr}M_{pr}}(T_{pc} + \Delta^{\circ}) - \frac{m_{pr}^{\circ}}{M_{pr}}\hat{T}_{pr}\right) \\
\dot{T}_{pr,wall,ref} &= \frac{k_{wall}}{c_{p,wall}}(T_{pr,ref} - T_{pr,wall,ref}) - \frac{1}{c_{p,wall}}W_{loss,pr}^{\circ} \\
W_{heat,pr} &= -\left(k_{wall} + c_{p,pr}M_{pr}\frac{k_{wall}}{c_{p,wall}}\right)(T_{pr,wall} - T_{pr,wall,ref}) \\
&\quad + c_{p,pr}M_{pr}\left[\dot{T}_{pr,ref} + \frac{k_{wall}}{c_{p,pr}M_{pr}}(T_{pr,ref} - T_{pr,wall,ref})\right. \\
&\quad \left. - \delta_{pr}\left(\frac{c_{p,pc}m_{pr}^{\circ}}{c_{p,pr}M_{pr}}(T_{pc} + \Delta^{\circ}) - \frac{m_{pr}^{\circ}}{M_{pr}}T_{pr,ref}\right)\right]
\end{aligned} \tag{27}$$

with $T_{pr,wall,ref}(0) = T_{pr,ref}(0) - W_{loss,pr}^{\circ}/k_{wall}$, $T_{pr,ref}$ as in (20), M_{pr} as in (22), m_{pr}° as in (23), ensures the practical exponential stability of the error temperatures [9].

It is worth noting that the controller (27) contains a term proportional to the error $e_{T_{pr,wall}}$. Simple modifications can include also an integral term $I_{e_{T_{pr,wall}}} = \int_0^t e_{T_{pr,wall}}(\tau) d\tau$, which is rather common in industrial plants. First, one considers the following pressurizer wall temperature nominal reference system

$$\dot{T}_{pr,wall,ref} = \frac{k_{wall}}{c_{p,wall}}T_{pr,ref} - \frac{k_{wall}}{c_{p,wall}}T_{pr,wall,ref} + k_i \int_0^t (T_{pr,wall}(\tau) - T_{pr,wall,ref}(\tau))d\tau - \frac{1}{c_{p,wall}}W_{loss,pr}^{\circ}$$

$k_i > 0$, with $T_{pr,wall,ref}(0) = T_{pr,ref}(0) - W_{loss,pr}^{\circ}/k_{wall}$, so that

$$\dot{e}_{T_{pr,wall}} = \frac{k_{wall}}{c_{p,wall}}e_{T_{pr}} - \frac{k_{wall}}{c_{p,wall}}e_{T_{pr,wall}} - k_i I_{T_{pr,wall}} - \frac{1}{c_{p,wall}}\delta W_{loss,pr}$$

which, along with (25) and $\dot{I}_{e_{T_{pr,wall}}} = e_{T_{pr,wall}}$, constitutes the dynamics of the error system. The reference control is the same as in (24), while the control $u_{e,W}$ will be determined using the Lyapunov function

$$V = \frac{1}{2}e_{T_{pr}}^2 + \frac{1}{2}\begin{pmatrix} I_{e_{T_{pr,wall}}} \\ e_{T_{pr,wall}} \end{pmatrix}^T P \begin{pmatrix} I_{e_{T_{pr,wall}}} \\ e_{T_{pr,wall}} \end{pmatrix} + \frac{1}{2}z_{T_{pr}}^2$$

with $P = P^T > 0$ solution of the Lyapunov equation

$$PA + A^T P = -2Q, \quad A = \begin{pmatrix} 0 & 1 \\ -k_i & -\frac{k_{wall}}{c_{p,wall}} \end{pmatrix}$$

for a fixed $Q = Q^T > 0$. For instance,

$$Q = \begin{pmatrix} q_{11} & 0 \\ 0 & q_{22} \end{pmatrix}, \quad q_{11}, q_{22} > 0, \quad P = \begin{pmatrix} \left(\frac{c_{p,wall}}{k_{wall}k_i} + \frac{c_{p,wall}}{k_{wall}}\right)q_{11} + \frac{c_{p,wall}k_i}{k_{wall}}q_{22} & \frac{1}{k_i}q_{11} \\ \frac{1}{k_i}q_{11} & \frac{c_{p,wall}}{k_{wall}k_i}q_{11} + \frac{c_{p,wall}}{k_{wall}}q_{22} \end{pmatrix}.$$

Deriving V , one gets

$$\begin{aligned}\dot{V} = & -\left(\frac{m_{pr}^\circ}{M_{pr}} + \frac{k_{wall}}{c_{p,pr}M_{pr}}\right)e_{T_{pr}}^2 - \left(\frac{I_{e_{T_{pr},wall}}}{e_{T_{pr},wall}}\right)^T Q \left(\frac{I_{e_{T_{pr},wall}}}{e_{T_{pr},wall}}\right) - \left(\frac{m_{pr}^\circ}{M_{pr}} + \frac{k_{wall}}{c_{p,pr}M_{pr}}\right)z_{T_{pr}}^2 \\ & + \frac{k_{wall}}{c_{p,pr}M_{pr}}e_{T_{pr}}e_{T_{pr},wall} + \frac{1}{c_{p,pr}M_{pr}}e_{T_{pr}}u_{e,W} + \frac{k_{wall}}{c_{p,wall}}\left(\frac{I_{e_{T_{pr},wall}}}{e_{T_{pr},wall}}\right)^T PBe_{T_{pr}} \\ & + \frac{c_{p,pc}m_{pr}^\circ}{c_{p,pr}M_{pr}}e_{T_{pr}}\delta_\Delta + \frac{1}{M_{pr}}\left(T_{pr} + \frac{c_{p,pc}}{c_{p,pr}}(T_{pc} + \Delta)\right)e_{T_{pr}}\delta_{m_{pr}} - \frac{1}{c_{p,wall}}\left(\frac{I_{e_{T_{pr},wall}}}{e_{T_{pr},wall}}\right)^T PB\delta_{W_{loss,pr}} \\ & - \frac{T_{pr}}{M_{pr}}z_{T_{pr}}\delta_{m_{pr}} + \frac{c_{p,pc}m_{pr}}{c_{p,pr}M_{pr}}z_{T_{pr}}\delta_\Delta\end{aligned}$$

where $B = (0 \ 1)^T$. Setting

$$u_{e,W} = -k_{wall}e_{T_{pr},wall} - \frac{c_{p,pr}}{c_{p,wall}}k_{wall}M_{pr}B^T P \begin{pmatrix} I_{e_{T_{pr},wall}} \\ e_{T_{pr},wall} \end{pmatrix}$$

one gets

$$\begin{aligned}\dot{V} \leq & -\left(\frac{m_{pr,\min}^\circ}{M_{pr,\max}} + \frac{k_{wall}}{c_{p,pr}M_{pr,\max}}\right)e_{T_{pr}}^2 - \lambda_{\min}^Q \left\| \frac{I_{e_{T_{pr},wall}}}{e_{T_{pr},wall}} \right\|^2 - \left(\frac{m_{pr,\min}^\circ}{M_{pr,\max}} + \frac{k_{wall}}{c_{p,pr}M_{pr,\max}}\right)z_{T_{pr}}^2 \\ & + \frac{c_{p,pc}m_{pr,\max}^\circ}{c_{p,pr}M_{pr,\min}}|e_{T_{pr}}|\delta_\Delta + \frac{1}{M_{pr,\min}}|T_{pr,\max} + \frac{c_{p,pc}}{c_{p,pr}}(T_{pc,\max} + \Delta_{\max})||e_{T_{pr}}|\delta_{m_{pr}}| \\ & + \frac{1}{c_{p,wall}}\|P\| \left\| \frac{I_{e_{T_{pr},wall}}}{e_{T_{pr},wall}} \right\| |\delta_{W_{loss,pr}}| + \frac{T_{pr,\max}}{M_{pr,\min}}|z_{T_{pr}}|\delta_{m_{pr}} + \frac{c_{p,pc}m_{pr,\max}}{c_{p,pr}M_{pr,\min}}|z_{T_{pr}}|\delta_\Delta\end{aligned}$$

with λ_{\min}^Q the minimum eigenvalue of Q . Hence, the dynamic controller ensuring practical exponential stability is

$$\begin{aligned}\hat{T}_{pr} &= -\left(\frac{m_{pr}^\circ}{M_{pr}} + \frac{k_{wall}}{c_{p,pr}M_{pr}}\right)\hat{T}_{pr} + \frac{k_{wall}}{c_{p,pr}M_{pr}}T_{pr,wall} + \frac{1}{c_{p,pr}M_{pr}}W_{heat,pr} + \frac{c_{p,pc}m_{pr}^\circ}{c_{p,pr}M_{pr}}(T_{pc} + \Delta^\circ) \\ \hat{T}_{pr,wall,ref} &= \frac{k_{wall}}{c_{p,wall}}T_{pr,ref} - \frac{k_{wall}}{c_{p,wall}}T_{pr,wall,ref} + k_i I_{e_{T_{pr},wall}} - \frac{1}{c_{p,wall}}W_{loss,pr}^\circ \\ \dot{I}_{e_{T_{pr},wall}} &= T_{pr,wall} - T_{pr,wall,ref} \\ W_{heat,pr} &= -k_{wall}(T_{pr,wall} - T_{pr,wall,ref}) - \frac{c_{p,pr}}{c_{p,wall}}k_{wall}M_{pr}B^T P \begin{pmatrix} I_{e_{T_{pr},wall}} \\ T_{pr,wall} - T_{pr,wall,ref} \end{pmatrix} \\ &+ c_{p,pr}M_{pr} \left[\hat{T}_{pr,ref} + \left(\frac{m_{pr}^\circ}{M_{pr}} + \frac{k_{wall}}{c_{p,pr}M_{pr}}\right)T_{pr,ref} - \frac{k_{wall}}{c_{p,pr}M_{pr}}T_{pr,wall,ref} \right. \\ &\left. - \frac{c_{p,pc}m_{pr}^\circ}{c_{p,pr}M_{pr}}(T_{pc} + \Delta^\circ) \right]\end{aligned}\tag{28}$$

with $T_{pr,wall,ref}(0) = T_{pr,ref}(0) - W_{loss,pr}^\circ/k_{wall}$, $T_{pr,ref}$ as in (20), M_{pr} as in (22), m_{pr}° as in (23).

1.5.2.3 An alternative nonlinear controller

In this section a dynamic controller is determined, considering directly that the output to be controlled is the pressurizer pressure p_{pr} given in (12). Deriving p_{pr} one gets

$$\dot{p}_{pr} = \frac{D}{c_{p,pr}M_{pr}} \left[-k_{wall}(T_{pr} - T_{pr,wall}) + W_{heat,pr} + \delta_{pr}(c_{p,pc}m_{pr}(T_{pc} + \Delta) - c_{p,pr}m_{pr}T_{pr}) \right]$$

where as usual δ_{pr} is 1 if $m_{pr} > 0$ and 0 otherwise, and with

$$D(T_{pr}) = \frac{\partial p_{*,T}(T_{pr})}{\partial T_{pr}} = -c_1 + 2c_2T_{pr}. \quad (29)$$

In order to determine a pressure controller which depends on the (measured) temperature $T_{pr,wall}$, but not on the (unmeasured) temperature T_{pr} nor on the pressure p_{pr} , the following switching controller is designed to impose the tracking of a desired reference pressure $p_{pr,ref}$

$$W_{heat,pr} = k_{wall}(\hat{T}_{pr} - T_{pr,wall}) + C_{pr} + \delta_{pr}(c_{p,pr}m_{pr}^{\circ}\hat{T}_{pr} - c_{p,pc}m_{pr}^{\circ}(T_{pc} + \Delta^{\circ})) \quad (30)$$

with M_{pr} given by (22),

$$C_{pr} = \frac{c_{p,pr}M_{pr}}{\hat{D}} \left(\dot{p}_{pr,ref} - K_p(\hat{p}_{pr} - p_{pr,ref}) - K_i \int_0^t (\hat{p}_{pr}(\tau) - p_{pr,ref}(\tau)) d\tau \right)$$

$$\hat{D} = \frac{\partial p_{*,T}(T_{pr})}{\partial T_{pr}} \Big|_{T_{pr}=\hat{T}_{pr}} = -c_1 + 2c_2\hat{T}_{pr}$$

$K_p, K_i > 0$, and where the nominal condition (14) and the estimate \hat{T}_{pr} ,

$$\hat{p}_{pr} = c_0 - c_1\hat{T}_{pr} + c_2\hat{T}_{pr}^2$$

of the (unmeasured) T_{pr} , p_{pr} have been considered.

With the control (30), the pressurizer pressure dynamics become

$$\dot{e}_{p_{pr}} + K_p e_{p_{pr}} + K_i \int_0^t e_{p_{pr}}(\tau) d\tau = \Psi_e(z_{T_{pr}}) + \delta_e \quad (31)$$

where $e_{p_{pr}} = p_{pr} - p_{pr,ref}$ is the pressure tracking error, $z_{T_{pr}} = T_{pr} - \hat{T}_{pr}$ is the temperature estimation error, and where we have considered that

$$\begin{aligned} \hat{D} &= -c_1 + 2c_2\hat{T}_{pr}, & \hat{p}_{pr} &= c_0 - c_1\hat{T}_{pr} + c_2\hat{T}_{pr}^2 \\ D - \hat{D} &= 2c_2z_{T_{pr}}, & p_{pr} - \hat{p}_{pr} &= (c_2(T_{pr} + \hat{T}_{pr}) - c_1)z_{T_{pr}} \\ \Psi_e(z_{T_{pr}}) &= \Psi_z(z_{T_{pr}}) - \delta_{pr} \frac{m_{pr}^{\circ}}{M_{pr}} D z_{T_{pr}}, & \delta_e &= \delta_{pr} \Psi_{\delta} \begin{pmatrix} \delta_{m_{pr}} \\ \delta_{\Delta} \end{pmatrix} \\ \Psi_z(z_{T_{pr}}) &= -\frac{k_{wall}}{c_{p,pr}M_{pr}} D z_{T_{pr}} + K_p(c_2(T_{pr} + \hat{T}_{pr}) - c_1)z_{T_{pr}} + K_i \int_0^t (c_2(T_{pr}(\tau) + \hat{T}_{pr}(\tau)) - c_1)z_{T_{pr}}(\tau) d\tau \\ &+ \frac{2c_2}{c_{p,pr}M_{pr}} \left(\dot{p}_{pr,ref} - K_p(\hat{p}_{pr} - p_{pr,ref}) - K_i \int_0^t (\hat{p}_{pr}(\tau) - p_{pr,ref}(\tau)) d\tau \right) z_{T_{pr}} \\ \Psi_{\delta} &= \frac{D}{c_{p,pr}M_{pr}} \begin{pmatrix} c_{p,pc}(T_{pc} + \Delta) - c_{p,pr}T_{pr} & c_{p,pc}m_{pr}^{\circ}\delta_{\Delta} \end{pmatrix}. \end{aligned}$$

Note that $\Psi_z(z_{T_{pr}}) \rightarrow 0$ as $z_{T_{pr}} \rightarrow 0$ if $\Psi_z(\cdot)$ is a bounded function, as in the present case, where we assume that the temperatures (and hence the pressures) are bounded. This is physically obviously verified in normal plant operations.

Making use of the measured temperature T_{wall} , a reduced-order observer can be designed for T_{pr}

$$\begin{aligned}\dot{\xi} &= \hat{T}_{pr} - T_{pr,wall} - \frac{1}{k_{wall}} W_{loss,pr}^\circ - \frac{1}{k} \frac{1}{c_{p,pr} M_{pr}} C_{pr} \\ \hat{T}_{pr} &= k \left(\frac{c_{p,wall}}{k_{wall}} T_{pr,wall} - \xi \right)\end{aligned}\quad (32)$$

$k > 0$, where $W_{loss,pr}^\circ$ is the nominal values of the disturbance $W_{loss,pr}$. The temperature estimation error dynamics are

$$\begin{aligned}\dot{z}_{T_{pr}} &= -\lambda_z z_{T_{pr}} + \delta_z \\ \lambda_z &= k + \frac{k_{wall}}{c_{pr} M_{pr}} + \delta_{pr} \frac{m_{pr}^\circ}{M_{pr}} \\ \delta_z &= \frac{k}{k_{wall}} \delta_{W_{loss,pr}} + \delta_{pr} (c_{p,pc} (T_{pc} + \Delta^\circ) + c_{p,pr} T_{pr}) \delta_{m_{pr}}\end{aligned}\quad (33)$$

From (31), (33) one works out

$$\begin{aligned}\begin{pmatrix} \dot{I}_{e_{ppr}} \\ \dot{e}_{ppr} \end{pmatrix} &= A \begin{pmatrix} I_{e_{ppr}} \\ e_{ppr} \end{pmatrix} + B (\Psi_e(z_{T_{pr}}) + \delta_e) \\ \dot{z}_{T_{pr}} &= -\lambda_z z_{T_{pr}} + \delta_z\end{aligned}\quad (34)$$

with

$$A = \begin{pmatrix} 0 & 1 \\ -K_i & -K_p \end{pmatrix}, \quad B = \begin{pmatrix} 0 \\ 1 \end{pmatrix}.$$

The stability study will be carried out considering that (33) is practically exponentially stable, and that the system given by the first two equations of (34) is ISS with respect to the input $z_{T_{pr}}$ [9], since $\Psi_z(\cdot)$ is a bounded function. Therefore, the origin of (33) is practically exponentially stable. In fact, considering the following Lyapunov function

$$V = \frac{1}{2} \begin{pmatrix} I_{e_{ppr}} \\ e_{ppr} \end{pmatrix}^T P \begin{pmatrix} I_{e_{ppr}} \\ e_{ppr} \end{pmatrix} + \frac{1}{2} z_{T_{pr}}^2, \quad P = P^T > 0 \quad (35)$$

and with P solution of the Lyapunov equation $PA + A^T P = -Q$, with $Q = Q^T > 0$ fixed. For instance,

$$Q = \begin{pmatrix} q_{11} & 0 \\ 0 & q_{22} \end{pmatrix}, \quad q_{11}, q_{22} > 0, \quad P = \begin{pmatrix} \left(\frac{K_p}{K_i} + \frac{1}{K_p} \right) q_{11} + \frac{K_i}{K_p} q_{22} & \frac{1}{K_i} q_{11} \\ \frac{1}{K_i} q_{11} & \frac{1}{K_p K_i} q_{11} + \frac{1}{K_p} q_{22} \end{pmatrix}.$$

Hence, deriving (35), one obtains

$$\begin{aligned}\dot{V} &= - \begin{pmatrix} I_{e_{ppr}} \\ e_{ppr} \end{pmatrix}^T Q \begin{pmatrix} I_{e_{ppr}} \\ e_{ppr} \end{pmatrix} - \lambda_z z_{T_{pr}}^2 - \begin{pmatrix} I_{e_{ppr}} \\ e_{ppr} \end{pmatrix}^T P B (\Psi_e(z_{T_{pr}}) + \delta_e) + z_{T_{pr}} \delta_z \\ &\leq -\lambda_{\min}^Q \left\| \begin{pmatrix} I_{e_{ppr}} \\ e_{ppr} \end{pmatrix} \right\|^2 - \lambda_{z,\min} z_{T_{pr}}^2 + \|P\| D_{\max} \left(\frac{m_{pr,\max}}{M_{pr,\min}} + \frac{k_{wall}}{c_{p,pr} M_{pr,\min}} \right) \left\| \begin{pmatrix} I_{e_{ppr}} \\ e_{ppr} \end{pmatrix} \right\| |z_{T_{pr}}| \\ &\quad + \left\| \begin{pmatrix} I_{e_{ppr}} \\ e_{ppr} \end{pmatrix} \right\| \|P\| D_{\max} \frac{c_{p,pc} m_{pr,\min}}{c_{p,pr} M_{pr,\max}} \delta_\Delta + |z_{T_{pr}}| \frac{k}{k_{wall}} \delta_{W_{loss,pr}}\end{aligned}$$

where λ_{\min}^Q is the minimum eigenvalue of Q , $\lambda_{z,\min} = k + k_{\text{wall}}/(c_{pr}M_{pr,\max})$, $m_{pr,\min}$, $M_{pr,\max}$ are defined in (26)

$$B = \begin{pmatrix} 0 \\ 1 \end{pmatrix}, \quad D_{\max} = \max_{T_{pr}} \frac{\partial p_{*,T}(T_{pr})}{\partial T_{pr}} = \frac{\partial p_{*,T}(T_{pr})}{\partial T_{pr}} \Big|_{T_{pr,\max}}$$

and $T_{pr,\max}$ is maximal temperature in the pressurizer.

The observer gain is designed in order to ensure exponential stability in absence of the perturbations δ_{Δ} , $\delta_{W_{\text{loss},pr}}$

$$k > \frac{\|P\|^2}{4\lambda_{\min}^Q} \left(\frac{m_{pr,\max}}{M_{pr,\min}} + \frac{k_{\text{wall}}}{c_{p,pr}M_{pr,\min}} \right)^2. \quad (36)$$

In the presence of perturbations, the controller (30), (32) (36) ensures ultimate boundedness of the error trajectories, i.e. practical exponential stability to the origin, with ultimate bound given by

$$\mu = \frac{1}{\vartheta\lambda} \max \left\{ \|P\| D_{\max} \frac{c_{p,pc}m_{pr,\min}}{c_{p,pr}M_{pr,\max}} \delta_{\Delta}, \frac{k}{k_{\text{wall}}} \right\} \max \{ \delta_{\Delta}, \delta_{W_{\text{loss},pr}} \}$$

$$\lambda = \min \sigma \left(\begin{array}{cc} \lambda_{\min}^Q & \frac{1}{2}\|P\| \left(\frac{m_{pr,\max}}{M_{pr,\min}} + \frac{k_{\text{wall}}}{c_{p,pr}M_{pr,\min}} \right) \\ \frac{1}{2}\|P\| \left(\frac{m_{pr,\max}}{M_{pr,\min}} + \frac{k_{\text{wall}}}{c_{p,pr}M_{pr,\min}} \right) & k \end{array} \right)$$

$\vartheta \in (0, 1)$, and with σ the set of the eigenvalues of a matrix.

Finally, the dynamic switching pressure controller is

$$\begin{aligned} \dot{I}_{e_{pr}} &= c_0 - c_1 \hat{T}_{pr} + c_2 \hat{T}_{pr}^2 - p_{pr,\text{ref}} \\ \dot{\xi} &= \hat{T}_{pr} - T_{pr,\text{wall}} - \frac{1}{k_{\text{wall}}} W_{\text{loss},pr}^{\circ} - \frac{1}{k} \frac{1}{c_{p,pr}M_{pr}} C_{pr} \\ \hat{T}_{pr} &= k \left(\frac{C_{p,\text{wall}}}{k_{\text{wall}}} T_{pr,\text{wall}} - \xi \right) \\ C_{pr} &= \frac{c_{p,pr}M_{pr}}{-c_1 + 2c_2\hat{T}_{pr}} \left(\dot{p}_{pr,\text{ref}} - K_p (c_0 - c_1\hat{T}_{pr} + c_2\hat{T}_{pr}^2 - p_{pr,\text{ref}}) - K_i I_{e_{pr}} \right) \\ W_{\text{heat},pr} &= k_{\text{wall}}(\hat{T}_{pr} - T_{pr,\text{wall}}) + C_{pr} + \delta_{pr} (c_{p,pr}m_{pr}^{\circ}\hat{T}_{pr} - c_{p,pc}m_{pr}^{\circ}(T_{pc} + \Delta^{\circ})) \end{aligned} \quad (37)$$

Note that (37) contains tunable gains, which can be used to obtain a better transient behavior.

1.6 The implementation of the control model and the controllers in Simulink

In order to check the performance of a controller, a first step is to consider the implementation of the mathematical model used to derive the controller in a suitable simulation environment. There exist many options, both commercial and non commercial. In particular, Matlab[®] (Matrix Laboratory) is a numerical computing environment and fourth-generation programming language. Developed by MathWorks, Matlab allows matrix manipulations, plotting of functions and data, implementation of algorithms, creation of user interfaces, and interfacing with programs written in other languages, including C, C++, Java, and Fortran.

The basic capabilities of Matlab are extended by toolbox. Among the others Simulink[®], also developed by MathWorks, is a tool for modeling, simulating and analyzing multi-domain dynamic systems. Its primary interface is a graphical block diagramming tool and a customizable set of block libraries. It offers tight integration with the rest of the Matlab environment and can either drive Matlab or be scripted from it. Matlab/Simulink provides a graphical modeling environment that includes expandable libraries of predefined blocks and an interactive graphical editor for assembling and managing intuitive block diagrams.

Simulink is widely used in control theory and digital signal processing for multi-domain simulation and model-based design. Matlab/Simulink is a powerful tool in research and simulation of plant process control. Their users come from various backgrounds of engineering, science, and economics, and they are widely used in academic and research institutions as well as industrial enterprises.

1.7 Implementation in Simulink of the primary circuit of a nuclear power plant

In this section it is described how the equations (11) have been implemented in Simulink, along with the controllers presented in Section (1.5).

The whole scheme of the primary circuit with the controllers is given in Fig. 3

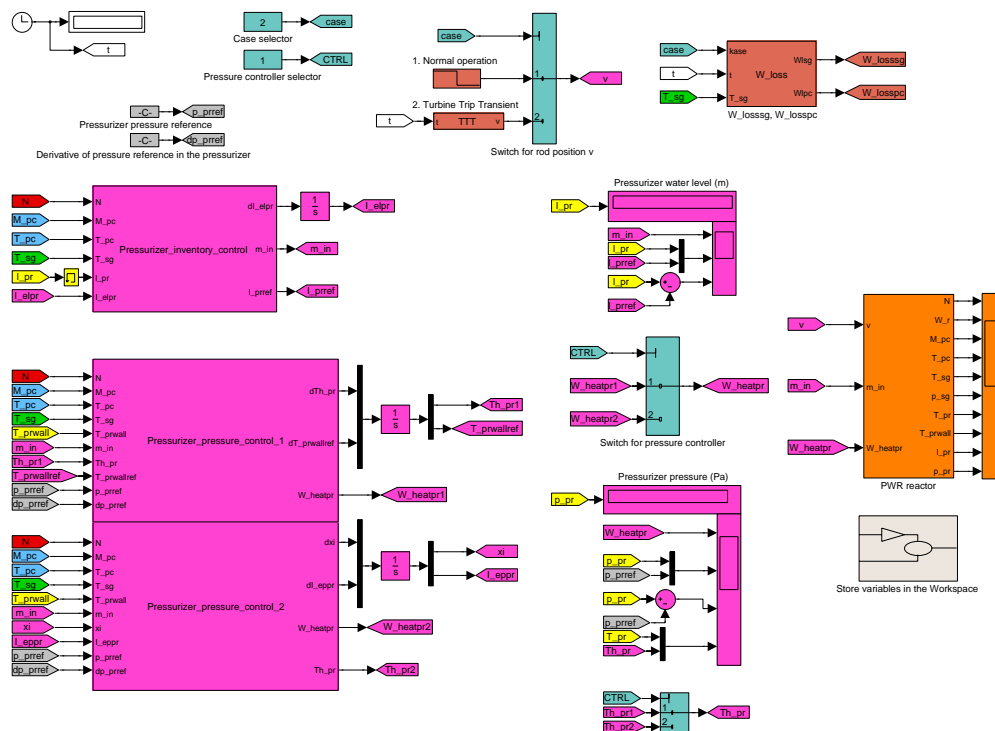

Figure 3: The control scheme for the primary circuit of a nuclear power plant

In the following the single blocks will be presented and commented.

1.7.1 The PWR reactor

The equations (11) are implemented in the block labelled PWR Reactor, see Fig. 4, which contains various subsystems, see Fig. 5, representing the (simplified) dynamics of the reactor (in red), the primary circuit (in light blue), the pressurizer (in yellow), and the steam generator (in green). Each of these block is an Embedded Matlab Function (EMF), which implements the dynamics as a function that is compiled at the beginning of the simulation. This ensures a faster simulation.

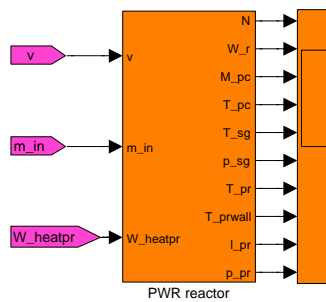

Figure 4: The control model of a PWR nuclear power plant

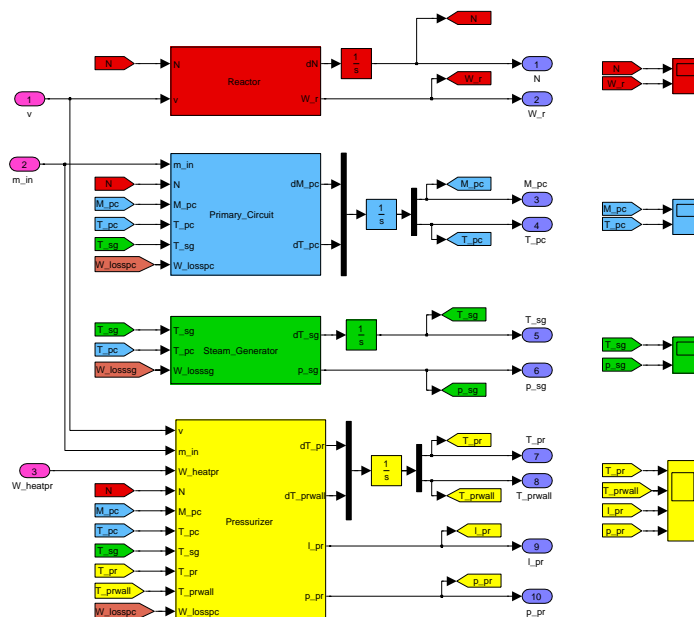

Figure 5: Details of the control model of a PWR nuclear power plant

In the following the implemented EMFs are detailed in the Tables 2–5

```

function [dN,W_r]=Reactor(N,v)
%#eml
%-----
% Initialization of the variables
% Reactor parameters
Lambda=0;
S=0;
p0=0;
p1=0;
p2=0;
c_psi=0;

%-----
% Loading current parameters from workspace
eml.extrinsic('evalin');
%eml.extrinsic('assignin');

% Load parameters from workspace
Lambda=evalin('base','Lambda');
S=evalin('base','S');
p0=evalin('base','p0');
p1=evalin('base','p1');
p2=evalin('base','p2');
c_psi=evalin('base','c_psi');

%-----
% Reactor dynamics
rho=(p0+p1*v+p2*v^2);
dN=- (rho/Lambda)*N+S;
W_r=c_psi*N;

```

Table 2: EMF “Reactor”

```

function [dM_pc,dT_pc]=Primary_Circuit(m_in,N,M_pc,T_pc,T_sg,W_losspc)
%#eml
%-----
% Initialization of the variables
% Primary circuit parameters
m_out=0;
c_ppc=0;
T_pci=0;
Delta=0;
n_sg=0;
k_tsg=0;
c_psi=0;

%-----
% Loading current parameters from workspace
eml.extrinsic('evalin');
%eml.extrinsic('assignin');

% Load parameters from workspace
m_out=evalin('base','m_out');
c_ppc=evalin('base','c_ppc');
T_pci=evalin('base','T_pci');
Delta=evalin('base','Delta');
n_sg=evalin('base','n_sg');
k_tsg=evalin('base','k_tsg');
c_psi=evalin('base','c_psi');

%-----
% Primary circuit dynamics
dM_pc=m_in-m_out;
dT_pc=(c_ppc*m_in*(T_pci-T_pc)+c_ppc*m_out*Delta+c_psi*N-n_sg*k_tsg*(T_pc-T_sg)
-W_losspc)/(c_ppc*M_pc);

```

Table 3: EMF “Primary circuit”

```

function [dT_sg,p_sg]=Steam_Generator(T_sg,T_pc,W_losssg)
%#eml
%-----
% Initialization of the variables
% Steam generator parameters
m_sg=0;
c_psgl=0;
c_psgv=0;
c0=0;
c1=0;
c2=0;
T_sgsw=0;
E_evapsg=0;
k_tsg=0;
M_sg=0;

%-----
% Loading current parameters from workspace
eml.extrinsic('evalin');
%eml.extrinsic('assignin');

% Load parameters from workspace
m_sg=evalin('base','m_sg');
c_psgl=evalin('base','c_psgl');
c_psgv=evalin('base','c_psgv');
c0=evalin('base','c0');
c1=evalin('base','c1');
c2=evalin('base','c2');
T_sgsw=evalin('base','T_sgsw');
E_evapsg=evalin('base','E_evapsg');
k_tsg=evalin('base','k_tsg');
M_sg=evalin('base','M_sg');

%-----
% Steam generator dynamics
dT_sg=(m_sg*(c_psgl*T_sgsw-c_psgv*T_sg-E_evapsg)+k_tsg*(T_pc-T_sg)
      -W_losssg)/(c_psgl*M_sg);
p_sg=c0-c1*T_sg+c2*(T_sg)^2;

```

Table 4: EMF “Steam generators”

```

function [dT_pr,dT_prwall,l_pr,p_pr]=Pressurizer(v,m_in,W_heatpr,N,M_pc,
                                                T_pc,T_sg,T_pr,T_prwall,W_losspc)

%#eml
%-----
% Initialization of the variables
% Pressurizer parameters
c_ppr=0;
c_ppc=0;
c_psi=0;
c_phi0=0;
c_phi1=0;
c_phi2=0;
c0=0;
c1=0;
c2=0;
A_pr=0;
n_sg=0;
k_tsg=0;
V_pc0=0;
k_wall=0;
c_pwall=0;

% Perturbations
m_out=0;
Delta=0;
W_losspr=0;
T_pci=0;

%-----
% Loading current parameters from workspace
eml.extrinsic('evalin');
%eml.extrinsic('assignin');

% Load parameters from workspace
c_ppr=evalin('base','c_ppr');
c_ppc=evalin('base','c_ppc');
c_psi=evalin('base','c_psi');
c_phi0=evalin('base','c_phi0');
c_phi1=evalin('base','c_phi1');
c_phi2=evalin('base','c_phi2');
c0=evalin('base','c0');
c1=evalin('base','c1');
c2=evalin('base','c2');
A_pr=evalin('base','A_pr');
n_sg=evalin('base','n_sg');
k_tsg=evalin('base','k_tsg');
V_pc0=evalin('base','V_pc0');
k_wall=evalin('base','k_wall');
c_pwall=evalin('base','c_pwall');

% Perturbations
m_out=evalin('base','m_out');
Delta=evalin('base','Delta');
W_losspr=evalin('base','W_losspr');

```

```

T_pci=evalin('base','T_pci');
%-----
% Pressurizer dynamics
density_pc=c_phi0+c_phi1*T_pc-c_phi2*(T_pc)^2;
derdensity_pc=c_phi1-2*c_phi2*T_pc;
M_pr=M_pc-density_pc*V_pc0;
m_pr=m_in-m_out-derdensity_pc*V_pc0*(c_ppc*m_in*(T_pci-T_pc)+c_ppc*m_out*Delta
+c_psi*N-n_sg*k_tsg*(T_pc-T_sg)-W_losspc)/(c_ppc*M_pc);
if m_pr>0,
    dT_pr=(-k_wall*(T_pr-T_prwall)+W_heatpr+c_ppc*m_pr*(T_pc+Delta)
-c_ppr*m_pr*T_pr)/(c_ppr*M_pr);
else
    dT_pr=(-k_wall*(T_pr-T_prwall)+W_heatpr)/(c_ppr*M_pr);
end
dT_prwall=(k_wall*(T_pr-T_prwall)-W_losspr)/c_pwall;
l_pr=(M_pc/density_pc-V_pc0)/A_pr;
p_pr=c0-c1*T_pr+c2*(T_pr)^2;

```

Table 5: EMF “Pressurizer”

In Fig. 6 the block `Pressurizer_inventory_control` represents the implementation of the controller (18). The EMF is given in Table 6. In the digital display on the right it is possible to check the numeric value of l_{pr} , while the input m_{in} , the behavior of l_{pr} , $l_{pr,ref}$, and the error $l_{pr} - l_{pr,ref}$ are given in the analog display.

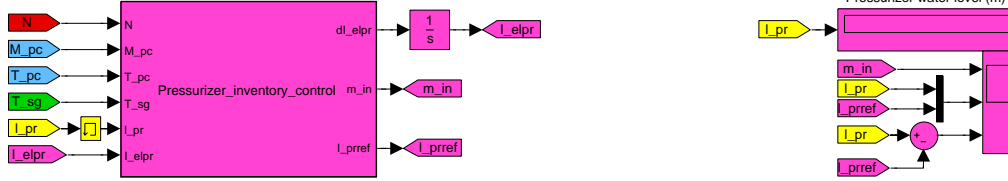

Figure 6: The pressurizer water level controller

The gains of the inventory control, $k_p = 100$, $k_i = 50$, have been tuned in order to obtain good transient. The initial condition for the integral action has been set to zero. A saturation on the input has been considered, so that $m_{in} \in [0, 20]$ kg/s. See Table 9.

A selector allows for changing between the pressurizer pressure controllers (27) and (37), see Fig.7.

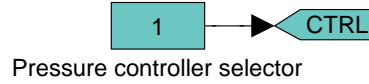

Figure 7: Pressurizer pressure controller selector

The blocks `Pressurizer_pressure_control1` and `Pressurizer_pressure_control2` in Fig. 8 represent the implementation of the controllers (27) and (37). The corresponding EMFs are given in Tables 7 and 8. A switch automatically consider the selected pressure controller, while the behaviors of the pressure p_{pr} , of the input $W_{heat,pr}$, the pressure p_{pr} versus the reference pressure $p_{pr,ref}$, the error $p_{pr} - p_{pr,ref}$, the temperature T_{pr} versus the estimated one \hat{T}_{pr} , can be check on the digital and analog displays.

The reference pressure has been set to $p_{pr,ref} = 12300$ kPa, with zero derivative. A saturation on the input has been considered, so that $W_{heat,pr} \in [0, 3.6 \times 10^5]$ W. See Table 9. The initial value for the pressure control (27) has been set equal to $T_{pr,wallref}(0) = T_{pr,ref}(0) - W_{loss,pr}^{\circ}/k_{wall}$ (in °C), with $T_{pr,ref}(0) = 326.51$ °C. See Table 9.

For the pressure control (37), the gains have been set $K_p = 2\zeta\omega_n$, $K_i = \omega_n^2$, with $\zeta = 0.4$, $\omega_n = 1$. The observer gain has been set to $k = 2000$, while the integrator initial conditions have been set equal to $\xi(0) = -\hat{T}_{pr}(0)/k + c_{p,wall}T_{pr,wall}(0)/k_{wall}$, $I_{e_{ppr}}(0) = 0$. See Table 9.

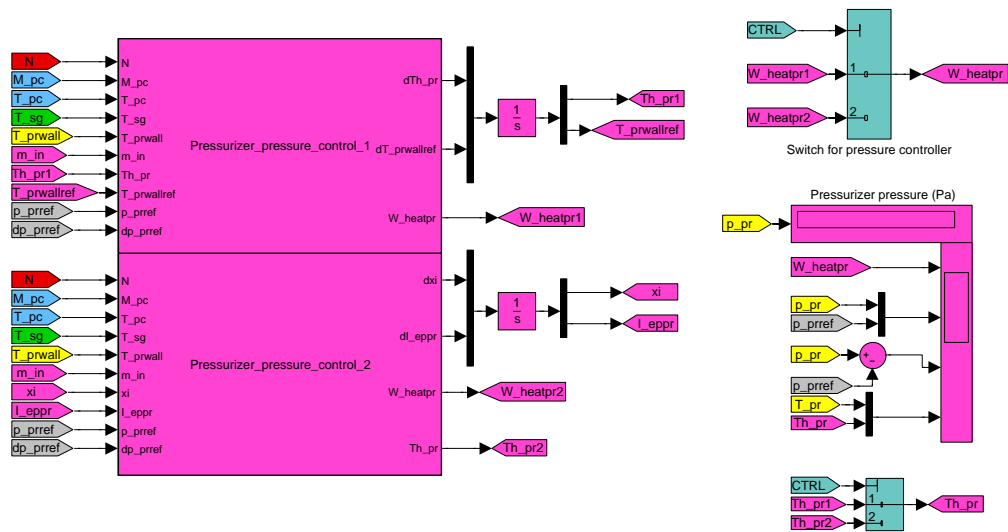

Figure 8: The pressurizer pressure controllers

A selector, Fig. 9, allows considering two cases

1. the normal operation of the plant;
2. the turbine trip transient (not described in this deliverable).

The reactor control rod are actuated consequently.

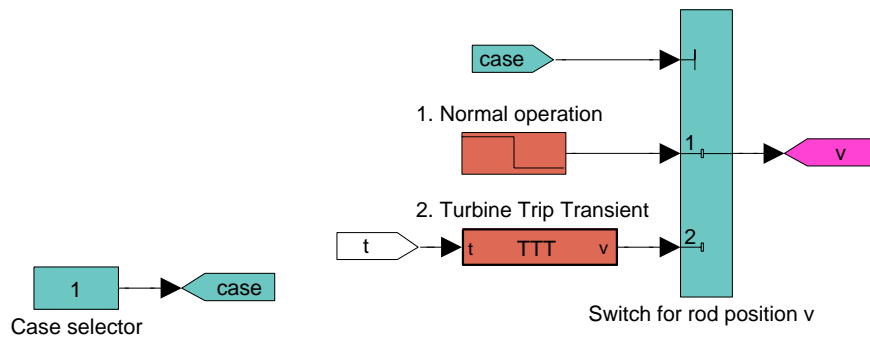

Figure 9: Case selector

```

function [dI_elpr,m_in,l_prref]=Pressurizer_inventory_control(N,M_pc,T_pc,T_sg,l_pr,I_elpr)
%#eml
%-----
% Initialization of the variables

% System parameters
Delta=0;
A_pr=0;
c_ppc=0;
c_psi=0;
c_phi0=0;
c_phi1=0;
c_phi2=0;
n_sg=0;
k_tsg=0;

% Reference parameters
c_r1=0;
c_r2=0;

% Perturbation parameters
m_out0=0;
T_pci0=0;
Delta0=0;
W_losspc0=0;

% Controller parameters
k_p=0;
k_i=0;

% Actuator parameter
minmax=0;

%-----
% Loading current parameters from workspace
eml.extrinsic('evalin');
%eml.extrinsic('assignin');

% Load parameters from workspace
% System parameters
Delta=evalin('base','Delta');
A_pr=evalin('base','A_pr');
c_ppc=evalin('base','c_ppc');
c_psi=evalin('base','c_psi');
c_phi0=evalin('base','c_phi0');
c_phi1=evalin('base','c_phi1');
c_phi2=evalin('base','c_phi2');
n_sg=evalin('base','n_sg');
k_tsg=evalin('base','k_tsg');

% Reference parameters
c_r1=evalin('base','c_r1');
c_r2=evalin('base','c_r2');

```

```

% Perturbation parameters
m_out0=evalin('base','m_out0');
T_pci0=evalin('base','T_pci0');
Delta0=evalin('base','Delta0');
W_losspc0=evalin('base','W_losspc0');

% Controller parameters
k_p=evalin('base','k_p');
k_i=evalin('base','k_i');

% Actuator parameter
minmax=evalin('base','minmax');

%-----
% Cold and hot leg temperatures
T_pccl=T_pc-Delta;
T_pchl=T_pc+Delta;

% Level reference (see Pisa's report)
l_prref=c_r1*(T_pccl+T_pchl)-c_r2;

% Function \phi and its derivative
phi=c_phi0+c_phi1*T_pc-c_phi2*T_pc^2;
dphi=c_phi1-2*c_phi2*T_pc;

% \psi function
psi=phi-(T_pci0-T_pc)*dphi-2*c_r1*A_pr*(T_pci0-T_pc)*phi^2/M_pc;

% Integral term
dI_elpr=l_pr-l_prref;

% Input m_{in}
min=A_pr*((2*c_r1*phi^2/M_pc+dphi)*(c_ppc*m_out0*Delta0+c_psi*N-n_sg*k_tsg*(T_pc-T_sg)
-W_losspc0)/c_ppc-(k_p*(l_pr-l_prref)+k_i*I_elpr)*phi^2+m_out0*phi)/psi;
if min<=0,
    m_in=0;
elseif min>=minmax;
    m_in=minmax;
else
    m_in=min;
end

```

Table 6: EMF “Pressurizer inventory control”

```

function [dTh_pr,dT_prwallref,W_heatpr]=Pressurizer_pressure_control_1(N,M_pc,T_pc,
T_sg,T_prwall,m_in,Th_pr,T_prwallref,p_prref,dp_prref)
%#eml
%-----
%Inizialization of variables

% System parameters
c_ppr=0;
c_ppc=0;
c_psi=0;
c_phi0=0;
c_phi1=0;
c_phi2=0;
c0=0;
c1=0;
c2=0;
n_sg=0;
k_tsg=0;
c_pwall=0;
k_wall=0;
V_pc0=0;

% Perturbation parameters
W_losspr0=0;
W_losspc0=0;
m_out0=0;
T_pci0=0;
Delta0=0;

% Actuator parameter
Wheatmax=0;

%-----
% Loading current parameters from workspace
eml.extrinsic('evalin');
%eml.extrinsic('assignin');

% Load parameters from workspace
% System parameters
c_ppr=evalin('base','c_ppr');
c_ppc=evalin('base','c_ppc');
c_psi=evalin('base','c_psi');
c_phi0=evalin('base','c_phi0');
c_phi1=evalin('base','c_phi1');
c_phi2=evalin('base','c_phi2');
c0=evalin('base','c0');
c1=evalin('base','c1');
c2=evalin('base','c2');
n_sg=evalin('base','n_sg');
k_tsg=evalin('base','k_tsg');
c_pwall=evalin('base','c_pwall');
k_wall=evalin('base','k_wall');
V_pc0=evalin('base','V_pc0');

```

```

% Perturbation parameters
W_losspr0=evalin('base','W_losspr0');
W_losspc0=evalin('base','W_losspc0');
m_out0=evalin('base','m_out0');
T_pci0=evalin('base','T_pci0');
Delta0=evalin('base','Delta0');

% Actuator parameter
Wheatmax=evalin('base','Wheatmax');

%-----
% Pressurizer pressure controller 1
T_prref=(c1+sqrt(c1^2-4*c2*(c0-p_prref)))/(2*c2);
dT_prref=4*c2*dp_prref/(2*c2*sqrt(c1^2-4*c2*(c0-p_prref)));
density_pc=c_phi0+c_phi1*T_pc-c_phi2*T_pc^2;
derdensity_pc=c_phi1-2*c_phi2*T_pc;
M_pr=M_pc-density_pc*V_pc0;
m_pr0=m_in-m_out0-derdensity_pc*V_pc0*(c_ppc*m_in*(T_pci0-T_pc)+c_ppc*m_out0*Delta0
+c_psi*N-n_sg*k_tsg*(T_pc-T_sg)-W_losspc0)/(c_ppc*M_pc);
if m_pr0>0,
    dpr=1;
else
    dpr=0;
end
W_heatprref=c_ppr*M_pr*dT_prref+k_wall*(T_prref-T_prwallref)
-dpr*(c_ppc*m_pr0*(T_pc+Delta0)-c_ppr*m_pr0*T_prref);
W_h=-k_wall*(1+c_ppr*M_pr/c_pwall)*(T_prwall-T_prwallref)+W_heatprref;
if W_h<0
    W_heatpr=0;
elseif W_h>Wheatmax,
    W_heatpr=Wheatmax;
else
    W_heatpr=W_h;
end
dTh_pr=(-k_wall*(Th_pr-T_prwall)+W_heatpr+dpr*(c_ppc*m_pr0*(T_pc+Delta0)
-c_ppr*m_pr0*Th_pr))/(c_ppr*M_pr);
dT_prwallref=k_wall*(T_prref-T_prwallref)/c_pwall-W_losspr0/c_pwall;

```

Table 7: EMF “Pressurizer pressure control 1”

```

function [dxi,dI_eppr,W_heatpr,Th_pr]=Pressurizer_pressure_control_2(N,M_pc,T_pc,
                                                                    T_sg,T_prwall,m_in,xi,I_eppr,p_prref,dp_prref)
%#eml
%-----
%Inizialization of variables

% System parameters
c_ppr=0;
c_ppc=0;
c_psi=0;
c_phi0=0;
c_phi1=0;
c_phi2=0;
c0=0;
c1=0;
c2=0;
n_sg=0;
k_tsg=0;
c_pwall=0;
k_wall=0;
V_pc0=0;

% Perturbation parameters
W_losspr0=0;
W_losspc0=0;
m_out0=0;
T_pci0=0;
Delta0=0;

% Controller parameters
Kp=0;
Ki=0;
k=0;

% Actuator parameter
Wheatmax=0;

%-----
% Loading current parameters from workspace
eml.extrinsic('evalin');
%eml.extrinsic('assignin');

% Load parameters from workspace
% System parameters
c_ppr=evalin('base','c_ppr');
c_ppc=evalin('base','c_ppc');
c_psi=evalin('base','c_psi');
c_phi0=evalin('base','c_phi0');
c_phi1=evalin('base','c_phi1');
c_phi2=evalin('base','c_phi2');
c0=evalin('base','c0');
c1=evalin('base','c1');
c2=evalin('base','c2');
n_sg=evalin('base','n_sg');

```

```

k_tsg=evalin('base','k_tsg');
c_pwall=evalin('base','c_pwall');
k_wall=evalin('base','k_wall');
V_pc0=evalin('base','V_pc0');

% Perturbation parameters
W_losspr0=evalin('base','W_losspr0');
W_losspc0=evalin('base','W_losspc0');
m_out0=evalin('base','m_out0');
T_pci0=evalin('base','T_pci0');
Delta0=evalin('base','Delta0');

% Controller parameters
Kp=evalin('base','Kp');
Ki=evalin('base','Ki');
k=evalin('base','k');

% Actuator parameter
Wheatmax=evalin('base','Wheatmax');

%-----
% Pressurizer pressure controller 2
density_pc=c_phi0+c_phi1*T_pc-c_phi2*T_pc^2;
derdensity_pc=c_phi1-2*c_phi2*T_pc;
M_pr=M_pc-density_pc*V_pc0;
m_pr0=m_in-m_out0-derdensity_pc*V_pc0*(c_ppc*m_in*(T_pci0-T_pc)+c_ppc*m_out0*Delta0
+c_psi*N-n_sg*k_tsg*(T_pc-T_sg)-W_losspc0)/(c_ppc*M_pc);
if m_pr0>0,
    dpr=1;
else
    dpr=0;
end
Th_pr=k*(c_pwall*T_prwall/k_wall-xi);
ph_pr=c0-c1*Th_pr+c2*Th_pr^2;
Dh=-c1+2*c2*Th_pr;
Cpr=c_ppr*M_pr*(dp_prref-Kp*(ph_pr-p_prref)-Ki*I_eppr)/Dh;
dxi=Th_pr-T_prwall-W_losspr0/k_wall-Cpr/(k*c_ppr*M_pr);
dI_eppr=ph_pr-p_prref;
W_h=k_wall*(Th_pr-T_prwall)+Cpr+dpr*(c_ppr*m_pr0*Th_pr-c_ppc*m_pr0*(T_pc+Delta0));
if W_h<0
    W_heatpr=0;
elseif W_h>Wheatmax,
    W_heatpr=Wheatmax;
else
    W_heatpr=W_h;
end

```

Table 8: EMF “Pressurizer pressure control 2”

In Table 9 (in accordance with Table 1) the system parameters, the initial variable values, and the controller parameters are given.

```

% Data from the paper Fazekas, Szederkenyi, Hangos,
% A simple dynamic model of the primary circuit in VVER plants
% for controller design purposes
% Nuclear Engineering and Design, N. 237, pp. 1071-1087, 2007
% These values refer to UNIT 3.
clear all, clc
disp('Loading simulation data ...')
disp('(see help for details)')
disp(' ')

%=====
% Reactor parameters
%-----
Lambda=1e-5;          % generation time; s
S=2830.05;           % flux of the constant neutron source; %/s
p0=2.85e-4;          % rod reactivity coefficients; m
p1=6.08e-5;          %                               m^(-1)
p2=1.322e-4;         %                               m^(-2)

%-----
% Primary Circuit parameters
%-----
c_ppc=5355;          % specific heat at 280 C; J/(kg*K)
c_psi=13.75e6;       % power reactor constant; W/%
n_sg=6;              % number of steam generatots in Paks Nuclear Power Plant

% Perturbations
m_out0=2.11;         % nominal outlet mass flow rate; kg/s
m_out=2.0678;        % real outlet mass flow rate: -2% of m_out0; kg/s
T_pci0=258.85;       % nominal inlet temperature; C
T_pci=256.2615;      % real inlet temperature: -1% of T_pci0; C
W_losspc0=2.996e7;   % nominal heat loss; J/s
W_losspc=3.07976e7; % real heat loss: +3% of W_losspc0; J/s
Delta0=15;           % nominal difference between T_pc and T_pc,cl; C
Delta=15.6;          % real difference between T_pc and T_pc,cl: +4% of Delta0; C

%-----
% Steam Generator parameters
%-----
m_sg=119.31;         % inlet secondary water mass flow rate = outlet secondary steam
                    %                               mass flow rate; kg
c_psgl=3809.9;       % second. circuit liquid water specific heat at 260 C; J/(kg K)
c_psgv=3635.6;       % second. circuit steam water specific heat at 260 C; J/(kg K)
T_sgsw= 220.85;      % second. circuit inlet temperature; C
E_evapsg=1.658e6;    % evaporation energy at 260 C; J/kg
k_tsg=9.5296e6;      % steam generator heat transfer coefficient; J/(K s)
M_sg=34920;          % water mass; kg

% Perturbations
W_losssg0=1.8932e7; % nominal heat loss; J/s
W_losssg=1.9689e7; % real heat loss: +4% of W_losssg0; J/s

```

```

%-----
% Pressurizer parameters
%-----
c_ppr=6873.1;      % specific heat of the water; J/(kg*K)
V_pc0=242;        % water nominal volume; m^3
c_phi0=581.2;     % coefficients of the density quadratic function; []
c_phi1=2.98;
c_phi2=0.00848;
c0=28884.78;     % coefficients of the saturated vapor; kPa
c1=258.01;       %                               ; kPa/C
c2=0.63455;     %                               ; kPa/C^2
A_pr=4.52;       % vessel cross section; m^2
k_wall=1.9267e8; % wall heat transfer coefficient; W/C
c_pwall=6.4516e7; % wall heat capacity; J/C

% Perturbations
W_losspr0=1.6823e5; % nominal heat loss; J/s
W_losspr=1.7159e5; % real heat loss: +2% of W_losspr; J/s

%-----
% Nominal inputs
%-----
v0=0;            % input: nominal rod position; cm
m_in0=2.11;      % input: nominal inlet mass flow rate; kg/s
W_heatpr0=168000; % input: nominal heating power; W

%-----
% Steady state conditions
%-----
% Reactor initial Condition
N0=Lambda*S/p0; % =99.3% Note: The neutron flux N is measured in percent

% Primary Circuit initial conditions
M_pc0=2e5;      % water mass in the primary circuit; kg

% Primary circuit and Steam generator initial conditions
A=[c_ppc*m_in0+n_sg*k_tsg  -n_sg*k_tsg;
   -k_tsg                  m_sg*c_psgv+k_tsg];
B=[c_ppc*m_in0*T_pci+c_ppc*m_out*Delta+c_psi*N0-W_losspc;
   m_sg*(c_psgl*T_sgsw-E_evapsg)-W_losssg];
C=inv(A)*B;
T_pc0=C(1,1);
T_sg0=C(2,1);
clear A B C

% Pressurizer initial conditions
T_pr0=326.51;   % C
T_prwall0=T_pr0-W_losspr/k_wall;

%-----
% Pressurizer water level reference parameters
%-----
% pressurizer water level at nominal conditions

```



```

l_pr0=(M_pc0/(c_phi0+c_phi1*T_pc0-c_phi2*T_pc0^2)-V_pc0)/A_pr;

c_r1=0.093;          % m/C
c_r2=2*c_r1*T_pc0-l_pr0;    % m

%-----
% Turbine trip transient (TTT)
%-----
tTTT=100;           % instant of occurrence of the reactivity transiento
                    % or the turbine trip transient; s
DeltaTTT=8;         % interval during which T_pc raises after TTT; s
DeltaFIN=2;         % interval after which all the transient ends; s
DeltaTTN=1.1;       % delay for reducing reactor power; s

t0=tTTT;            % strarts I transient
t1=tTTT+DeltaTTT;  % ends I transient and strarts II transient
t2=t1+DeltaFIN;     % strarts II transient

Wsg0=W_losssg;     % initial value I transient
Wsg1=-45*W_losssg; % final value I trans. and initial value II trans.
Wsg2=0.7*W_losssg; % final value II transient

Wpc0=W_losspc;
Wpc1=-10*W_losspc;
Wpc2=0.8*W_losspc;

a=p2;               % determination of rod position correspondig to
b=p1;               % N= 80% of N0
c=p0-Lambda*S/(N0*0.80);
vTTT=(-b+sqrt(b^2-4*a*c))/(2*a);
clear a b c

valve_closed=1;     % flag of the valve
Tsgmax=270;         % Tsg value at which valve opens

%-----
% Pressurizer water level controller parameters
%-----
k_p=100;
k_i=50;

% Initial condition (integral action)
I_elpr0=0;

% Actuator parameter (saturation)
minmax=20;          % kg/s

%-----
% Pressurizer pressure controller
%-----
% Pressure reference and derivative
p_prref=12300;      % kPa
dp_prref=0;

```

```

% Actuator parameter (saturation)
Wheatmax=3.6e5; % W

% Temperature observer initial conditions
Th_pr0=324; % C

%-----
% Controller 1 parameters and initial values
% Initial conditions
T_prref0=326.51; % C
T_prwallref0=T_prref0-W_losspr0/k_wall; % C

%-----
% Controller 2 parameters and initial values
% Controller gains
zeta=0.7; % damping
wn=100; % natural frequency
Kp=2*zeta*wn;
Ki=wn^2;

% Observer gain
k=200;

% Integrator initial conditions
xi0=-Th_pr0/k+c_pwall*T_prwall0/k_wall;
I_epr0=0;

%=====
disp('... data loaded!')
disp('Starting simulation.')

```

Table 9: Initial data file

1.8 Simulation results

Simulations have been carried out to check the performance of the designed controllers. The simulation parameters are given in Table 1. In Table 9 the same values have been reported in the initialization data file. Perturbations have been considered to render more realistic these simulations, with variations of -2% for m_{out}° , -1% for $T_{pc,i}^{\circ}$, $+4\%$ for Δ° , $+3\%$ for $W_{loss,pc}^{\circ}$, $+4\%$ for $W_{loss,sg}^{\circ}$, and $+2\%$ for $W_{loss,pr}^{\circ}$.

1.8.1 Controllers (18), (27)

In Figs. 10–17 the simulation results of the application of the controllers (18), (27) are summarized. After a short transient of about 50 s, the pressurizer temperature T_{pr} reaches the steady state value. Moreover, at $t = 100$ s, a reactivity transient is imposed changing the control rod position from the value $\nu = 0$, corresponding to $N = 99.3\%$, to $\nu = -2.75 \times 10^{-3}$. This imposes a new transient to T_{pr} of about 145 s. Similar transients can be noticed on the pressurizer pressure p_{pr} . The primary circuit temperature T_{pc} has longer transients, so that also l_{pr} , whose reference is a function of this temperature, slowly reaches the steady state value. During this transit, however, the inventory control ensures an almost perfect tracking of the reference $l_{pr,ref}$, except for a small steady state error that can be eliminated with an integral action, i.e. with the controller (28).

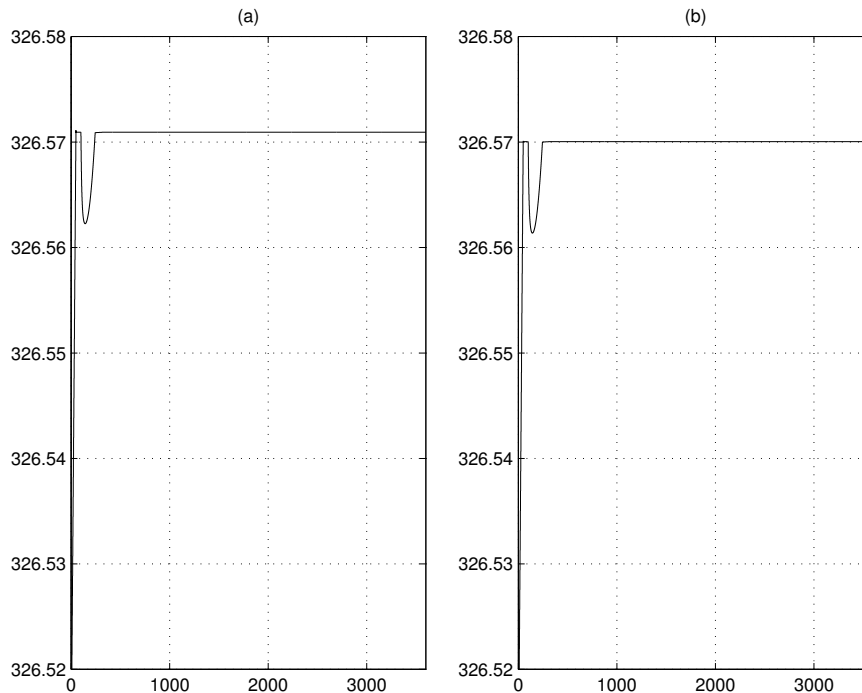

Figure 10: Controllers (18), (27). (a) Pressurizer temperature T_{pr} [°C]; (b) Pressurizer wall temperature $T_{pr,wall}$ [°C]

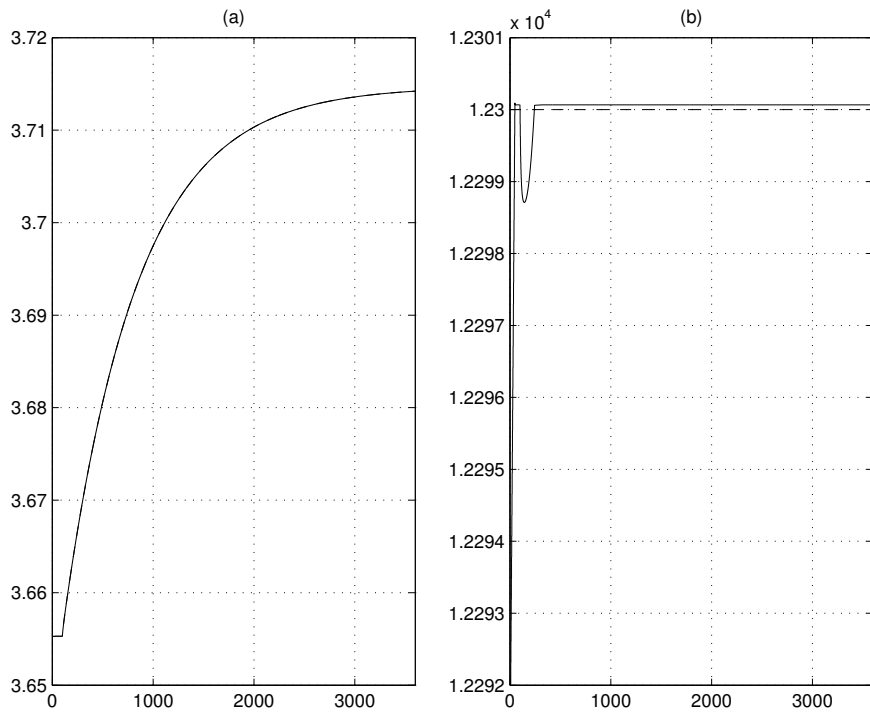

Figure 11: Controllers (18), (27). (a) Pressurizer water level l_{pr} (solid) and reference $l_{pr,ref}$ (dashed) [m]; (b) Pressurizer pressure p_{pr} (solid) and reference $p_{pr,ref}$ (dashed) [kPa]

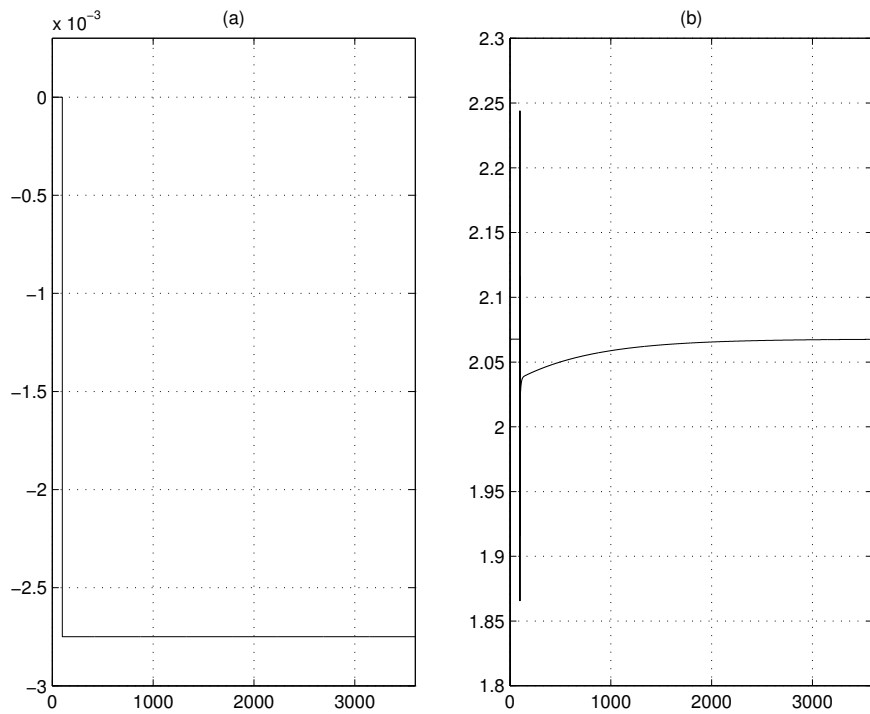

Figure 12: Controllers (18), (27). (a) Rod position ν [m]; (b) Inlet mass flow rate m_{in} [kg/s]

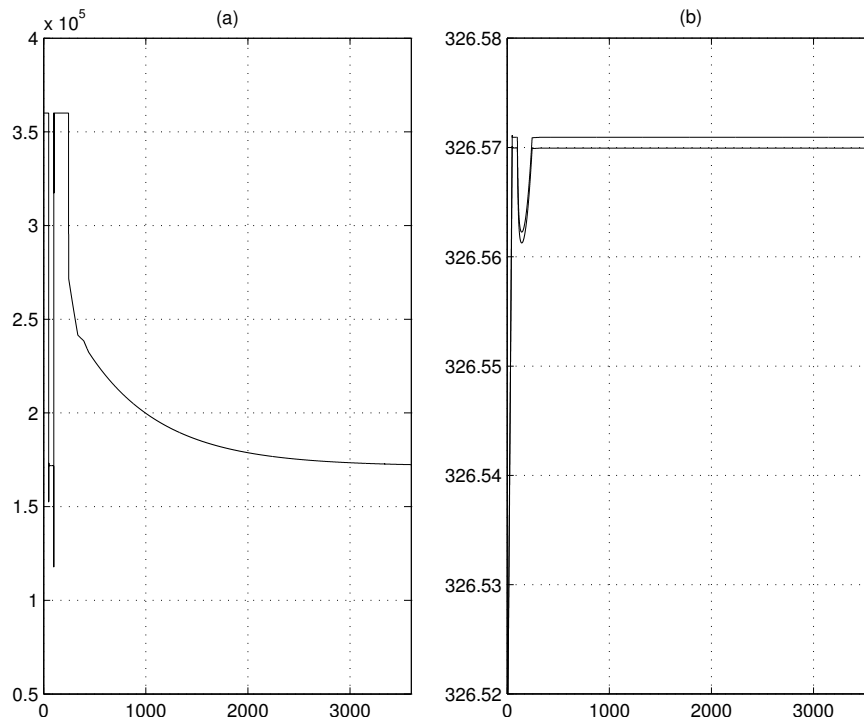

Figure 13: Controllers (18), (27). (a) Pressurizer heating power $W_{heat,pr}$ [kW]; (b) Pressurizer temperature T_{pr} (solid) and estimate \hat{T}_{pr} (dashed) [°C]

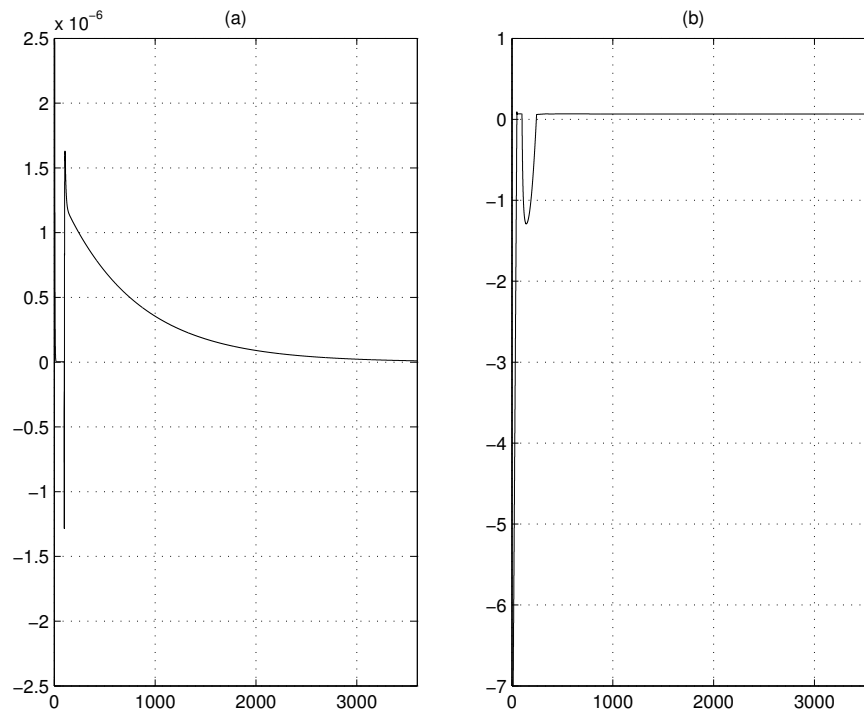

Figure 14: Controllers (18), (27). (a) Pressurizer level error $l_{pr} - l_{pr,ref}$ [m]; (b) Pressurizer pressure error $p_{pr} - p_{pr,ref}$ [kPa]

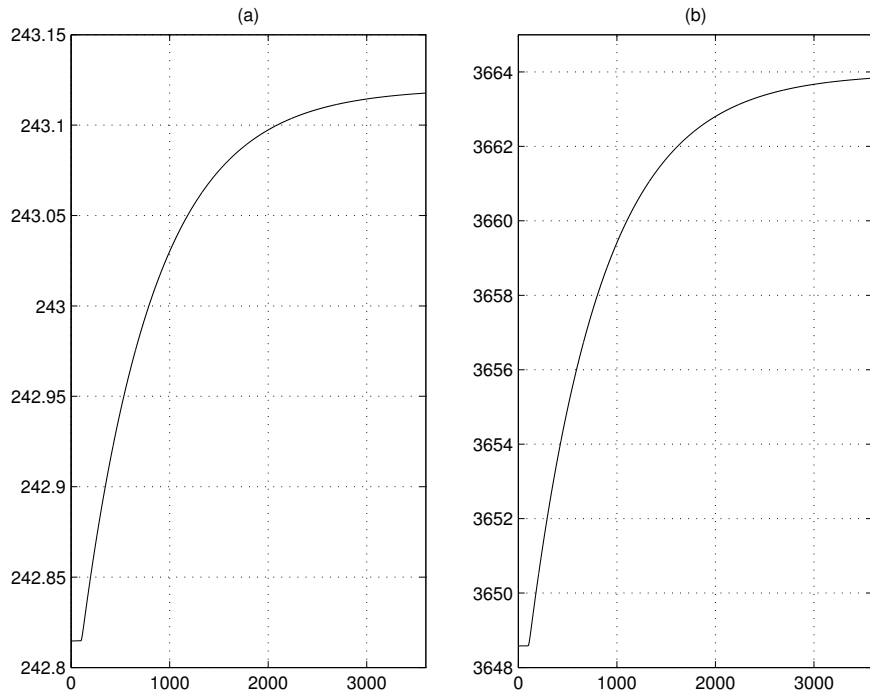

Figure 15: Controllers (18), (27). (a) Steam generator temperature T_{sg} [$^{\circ}\text{C}$]; (b) Steam generator pressure p_{sg} [kPa]

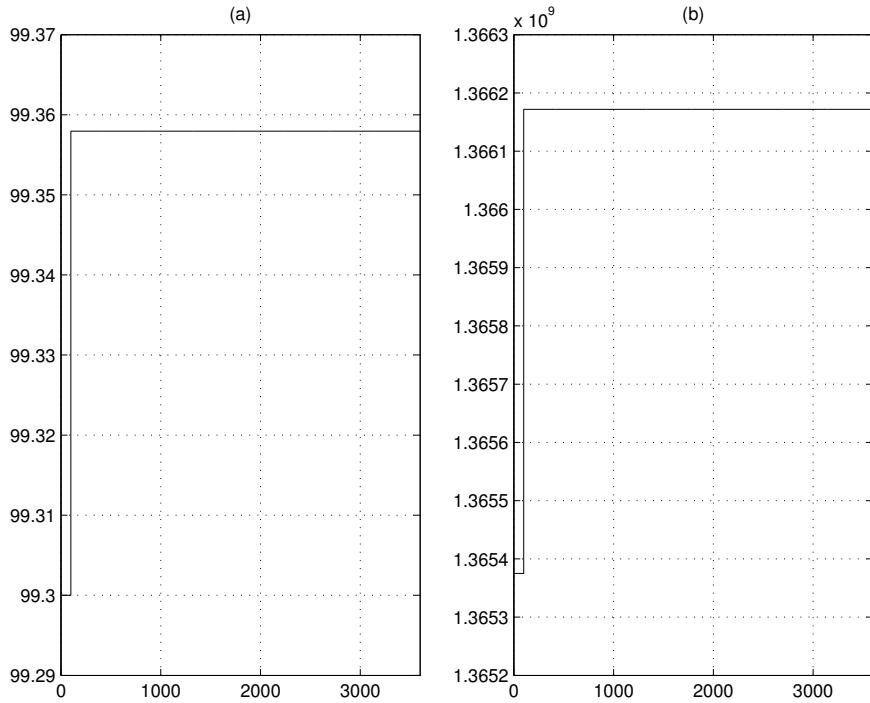

Figure 16: Controllers (18), (27). (a) Neutron flux N [%]; (b) Reactor power W_r [W]; (c) Primary Circuit water mass M_{pc} [kg]

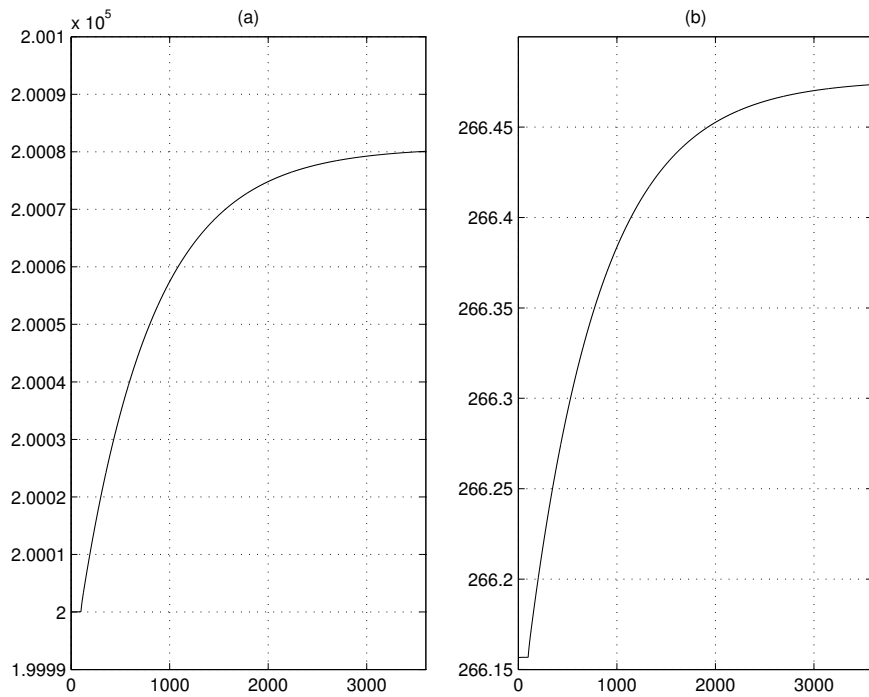

Figure 17: Controllers (18), (27). (a) Primary Circuit water mass M_{pc} [kg]; (b) Primary Circuit temperature T_{pc} [$^{\circ}\text{C}$]

1.8.2 Controllers (18), (37)

In Figs. 18–25 the simulation results of the application of the controllers (18), (37) are summarized. The results are pretty close to those obtained with the controllers (18), (27), except for steady state tracking error of p_{pr} , due to the presence of an integral action in (37).

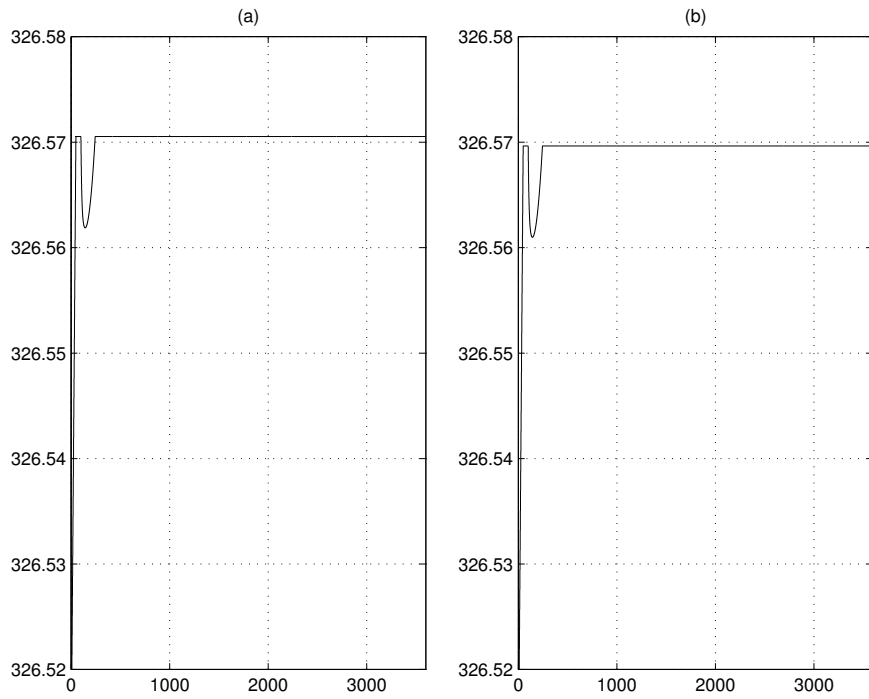

Figure 18: Controllers (18), (37). (a) Pressurizer temperature T_{pr} [°C]; (b) Pressurizer wall temperature $T_{pr,wall}$ [°C]

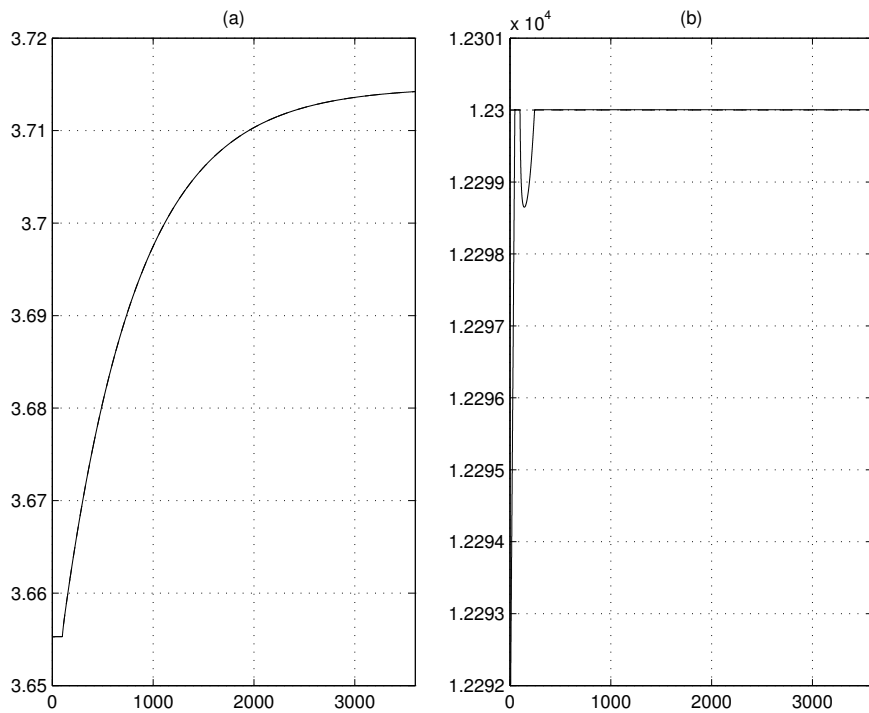

Figure 19: Controllers (18), (37). (a) Pressurizer water level l_{pr} (solid) and reference $l_{pr,ref}$ (dashed) [m]; (b) Pressurizer pressure p_{pr} (solid) and reference $p_{pr,ref}$ (dashed) [kPa]

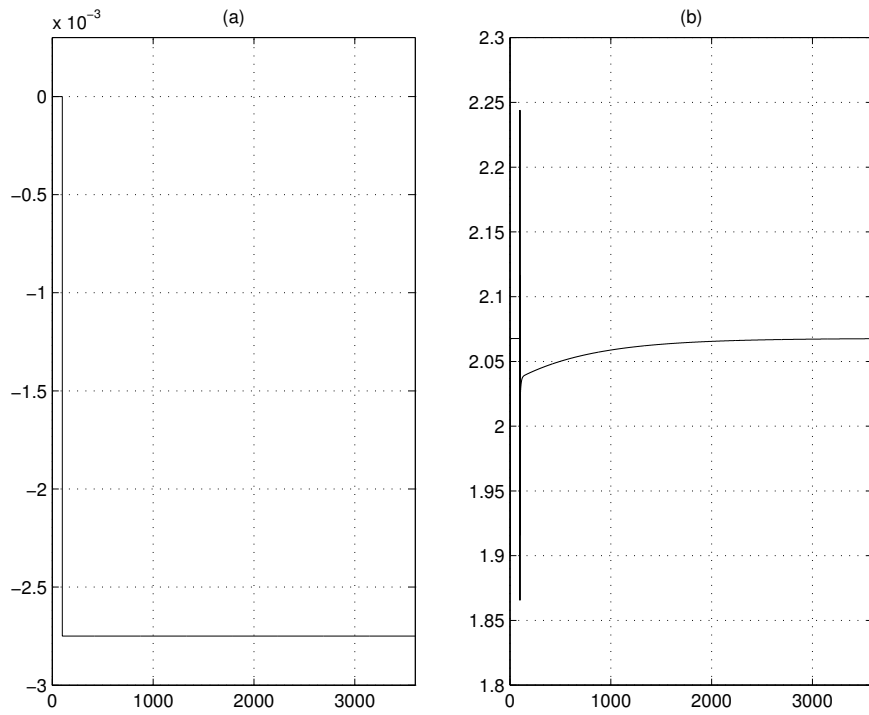

Figure 20: Controllers (18), (37). (a) Rod position v [m]; (b) Inlet mass flow rate m_{in} [kg/s]

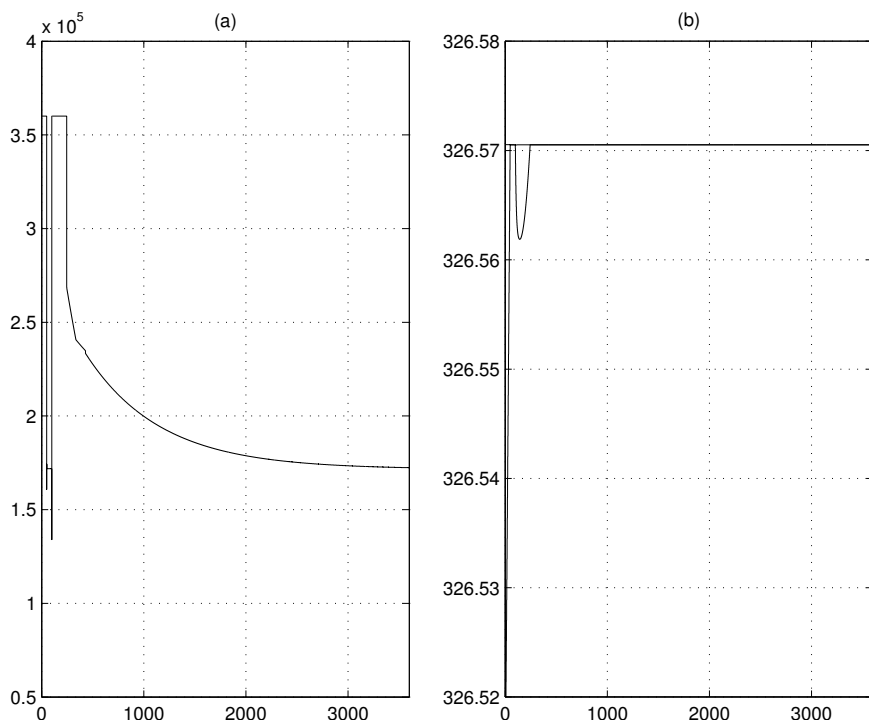

Figure 21: Controllers (18), (37). (a) Pressurizer heating power $W_{heat,pr}$ [kW]; (b) Pressurizer temperature T_{pr} (solid) and estimate \hat{T}_{pr} (dashed) [°C]

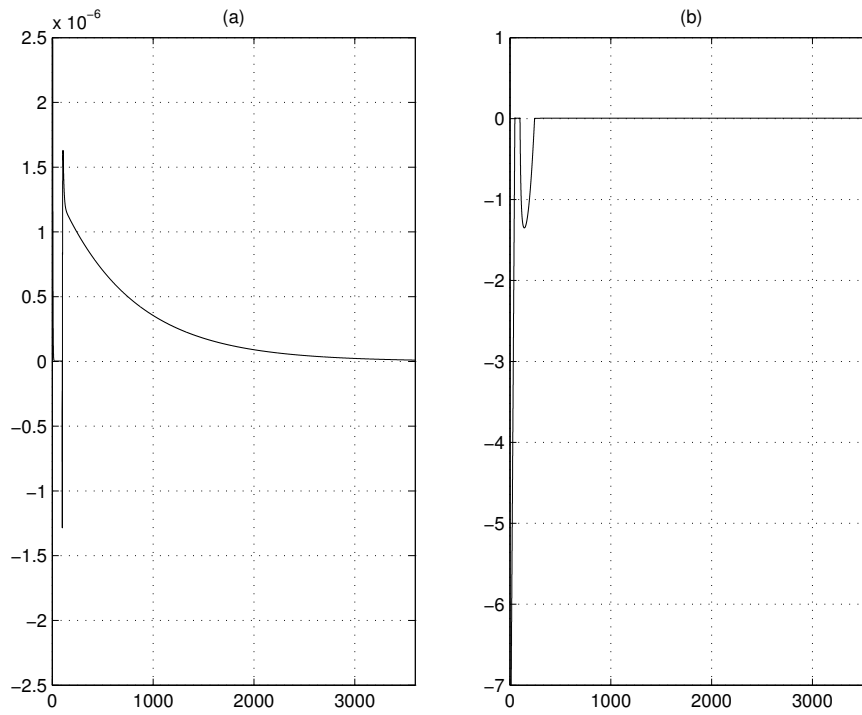

Figure 22: Controllers (18), (37). (a) Pressurizer level error $l_{pr} - l_{pr,ref}$ [m]; (b) Pressurizer pressure error $p_{pr} - p_{pr,ref}$ [kPa]

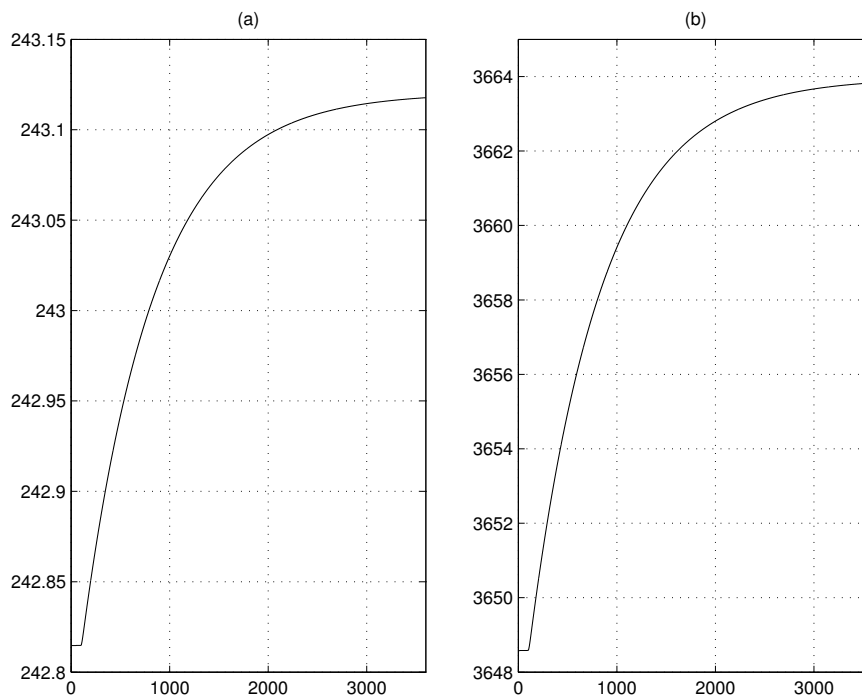

Figure 23: Controllers (18), (37). (a) Steam generator temperature T_{sg} [°C]; (b) Steam generator pressure p_{sg} [kPa]

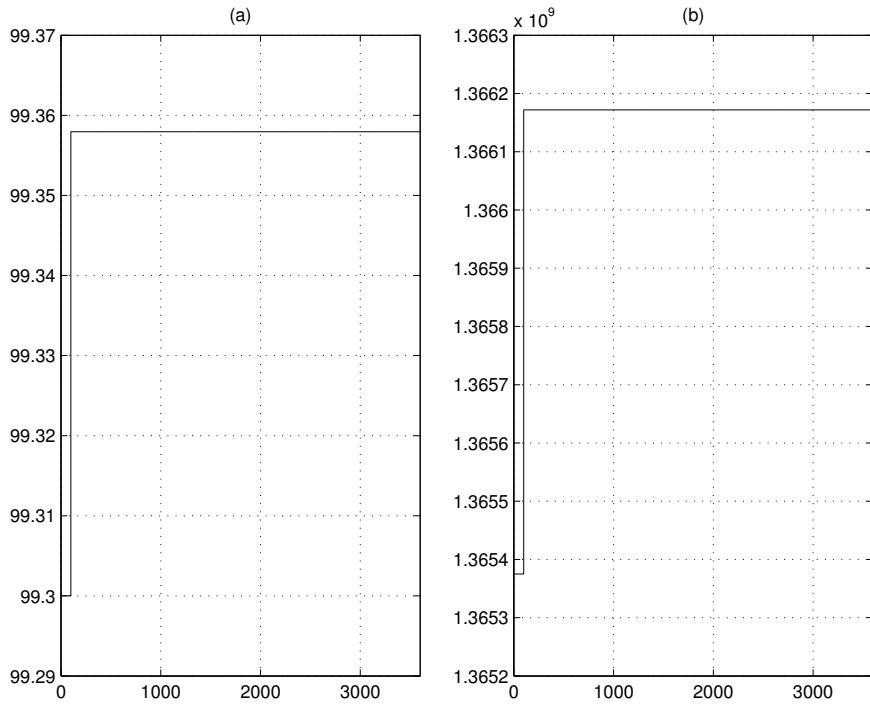

Figure 24: Controllers (18), (37). (a) Neutron flux N [%]; (b) Reactor power W_r [W]; (c) Primary Circuit water mass M_{pc} [kg]

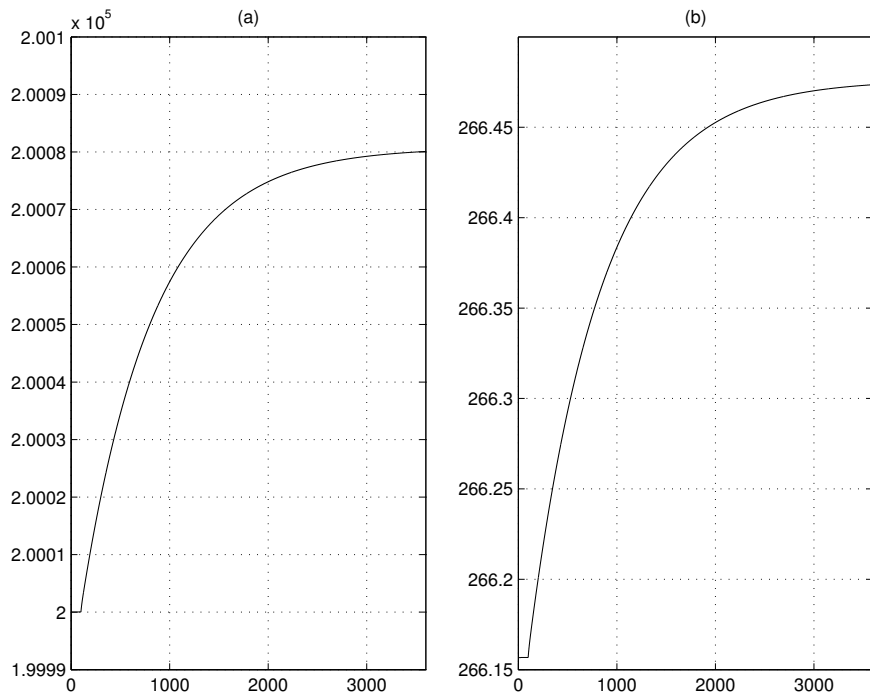

Figure 25: Controllers (18), (37). (a) Primary Circuit water mass M_{pc} [kg]; (b) Primary Circuit temperature T_{pc} [°C]

Conclusions

In this deliverable a simplified model for the primary circuit has been derived and used to determine an inventory controller and two dynamic pressure controller for the pressurizer of a PWR. These controllers ensure a good performance, also in the presence of uncertainties and disturbances. Their switching nature, reflecting the switching nature of the pressurizer dynamics, ensures better transient behaviors. Hence, they represent an evolution and an improvement with respect to classical PID controllers, usually implemented in standard control actions.

References

- [1] K. Aström, and R. Bell, Drum–Boiler Dynamics, *Automatica*, Vol. 36, pp. 363–378, 2001.
- [2] B. Castillo–Toledo, and S. Di Gennaro, Dynamic Controller for the Pressurizer in Pressurized Nuclear Reactors of New Generation, *Technical Report*, Dept. of Electric and Information Engineering, submitted, 2011. http://www.diel.univaq.it/tr/web/web_search_tr.php.
- [3] B. Castillo–Toledo, M. Cappelli, and S. Di Gennaro, Advanced Pressure Controllers for the Pressurizer in PWRs of New Generation, *Nuclear Engineering and Design*, submitted, 2011.
- [4] B. Castillo–Toledo, M. Cappelli, and S. Di Gennaro, Pressurizer Pressure Control in PWRs of New Generation, *Proceedings of the 8th International Topical Meeting on Nuclear Plant Instrumentation, Control, and Human–Machine Interface Technologies*, submitted, 2012.
- [5] C. Fazekas, G. Szederkényi, and K. Hangos, A Simple Dynamic Model of the Primary Circuit in VVER Plants for Controller Design Purposes, *Nuclear Engineering and Design*, pp. 1071–1087, 2006.
- [6] K. Hangos and I. Cameron, *Process Modelling and Model Analysis*, London, Academic Press, 2001.
- [7] IAEA – International Atomic Energy Agency, Pressurized Water Reactor Simulator, Training Course Series No. 22, IAEA–TCS–22, Workshop Material, 2003.
- [8] A. A. Karve, R. Uddin, and J. J. Dorning, Stability Analysis of BWR Nuclear–Coupled Thermal–Hydraulics using a Simple Model, *Nuclear Engineering and Design*, Vol. 177, pp. 155–177, 1997.
- [9] H. K. Khalil, *Nonlinear Systems*, Third Edition, Prentice Hall, Upper Saddle River, New Jersey, U.S.A., 2002.
- [10] N. Muellner, M. Lanfredini, Bases for Setting up a Thermal–Hydraulic Model of a Generic PWR Pressurizer, including Controls, Agreement N.IN.E S.r.l. – University of L’Aquila, 2011.
- [11] T. Péni, G. Szederkényi, and J. Bokor, Model Predictive Control of the Hybrid Primary Circuit Dynamics in a Pressurized Water Nuclear Power Plant, *Proceedings of the European Control Conference 2007*, pp. 5361–5367, Kos, Greece, July 2–5, 2007.
- [12] PWR–sim, *Pressurized Water Reactor Simulator*, IAEA–TCS–22, ISSN 1018–5518, IAEA, Vienna, 2003.
- [13] G. Szederkényi, Z. Szabó, J. Bokor, and K. M. Hangos, Analysis of the Networked Implementation of the Primary Circuit Pressurizer Controller at a Nuclear Power Plant, *Proceedings of the 16th Mediterranean Conference on Control and Automation*, Ajaccio, France, pp. 1604–1609, 2008.

- [14] ThermExcel, *ThermExcel Data Tables*, <http://www.thermexcel.com/english/tables>, 2006.
- [15] I. Varga, G. Szederkényi, P. Gáspár, and J. Bokor, Implementation of Dynamic Inversion-Based Control of a Pressurizer at the Paks NPP, *Proceedings of the 17th IEEE International Conference on Control Applications*, San Antonio, Texas, USA, pp. 79–84, 2008.