



Agenzia nazionale per le nuove tecnologie, l'energia
e lo sviluppo economico sostenibile



Ministero dello Sviluppo Economico

RICERCA DI SISTEMA ELETTRICO

Stato dell'arte sull'accoppiamento fra codici di sistema e di
fluidodinamica computazionale. Applicazione generale su sistemi a
metallo liquido pesante

L. Mengali, M. Lanfredini, F. Moretti, F. D'Auria



Report RdS/2012/062

STATO DELL'ARTE SULL'ACCOPIAMENTO FRA CODICI DI SISTEMA E DI FLUIDODINAMICA
COMPUTAZIONALE. APPLICAZIONE GENERALE SU SISTEMI A METALLO LIQUIDO PESANTE

L. Mengali, M. Lanfredini, F. Moretti, F. D'Auria – CIRTEEN Università di Pisa

Settembre 2012

Report Ricerca di Sistema Elettrico

Accordo di Programma Ministero dello Sviluppo Economico - ENEA

Area: Governo, gestione e sviluppo del sistema elettrico nazionale

Progetto: Nuovo nucleare da fissione: collaborazioni internazionali e sviluppo competenze in materia nucleare

Responsabile del Progetto: Mariano Tarantino, ENEA



CIRTEN

Consorzio Interuniversitario per la Ricerca Tecnologica Nucleare

UNIVERSITY OF PISA

S. PIERO A GRADO NUCLEAR RESEARCH GROUP

**Stato dell'arte sull'accoppiamento fra codici di sistema e di
fluidodinamica computazionale.
Applicazione generale su sistemi a metallo liquido pesante.**

Autori

L. Mengali

M. Lanfredini

F. Moretti

F. D'Auria

CERSE-UNIPI RL 1509/2011

PISA, 31 July 2012

Lavoro svolto in esecuzione dell'Attività LP3-C1.C
AdP MSE-ENEA sulla Ricerca di Sistema Elettrico - Piano Annuale di Realizzazione 2011
Progetto 1.3.1 "Nuovo Nucleare da Fissione:
collaborazioni internazionali e sviluppo competenze in materia nucleare"

List of Contents

List of Contents	2
List of Figures	3
Summary	4
1 Introduction	5
2 Literature Review	6
2.1 Coupled systems classification	6
2.1.1 Spatial domains	8
2.1.2 Coupling execution	8
2.1.3 Code integration	8
2.1.4 Synchronization	9
2.1.5 Information exchange type	9
2.1.6 Numerical schemes	10
2.2 Literature overview	12
2.3 Comparison and summary	16
3 Code Coupling Development	20
3.1 Selected Codes	20
3.1.1 RELAP5	20
3.1.2 ANSYS CFX	20
3.2 Coupling strategy	23
3.2.1 CFX	24
3.2.2 External coupling routine	25
3.2.3 CSES	26
4 Test Case	27
4.1 Pressure drop test: RELAP-pipe / CFX-pipe	27
4.1.1 Set up of the CFD model	27
4.1.2 Set up of the RELAP model	28
4.1.3 Results	29
5 Conclusions and future development	32
References	33
Curriculum Scientifico del Gruppo di Lavoro	36



List of Figures

Figure 1: Example of Coupled System	6
Figure 2: Coupling Strategy Sketch	23
Figure 3: CFX Coupling Routines	24
Figure 4: Flow Diagram of the Coupling Routine	25
Figure 5: ICEM Model of the CFX Pipe	28
Figure 6: Nodalization of the Pipe Modelled with RELAP	29
Figure 7: Max Residuals	29
Figure 8: Velocity Rise	30
Figure 9: Pressure Evolution	30
Figure 10: Pressure Along the Pipe Axis	31

Summary

The need for deeper and more accurate investigation of accidental scenarios and the challenges posed by the design of GEN IV reactors have increased the interest of the nuclear community toward CFD codes during the last years. Due to their relatively high computational costs, the CFD simulations cannot be used to replace system codes in the analysis of an entire thermal hydraulic system; they are rather meant for the analysis of local three-dimensional phenomena. A complex thermal hydraulic analysis generally requires different levels of simulations, from detailed local component-level CFD simulations to integral system-level simulations. The current state-of-the-art approaches to such multi-level analysis are mostly based on stand-alone system code and CFD simulations, even in presence of physically coupled problems (which – on the other hand – would require on-line mutual interaction and data exchange between the different solution levels). The availability of coupled simulation tools that combine system and CFD analysis would bring noticeable added value to the quality and reliability of complex thermal hydraulic studies or nuclear reactors, including liquid metal reactors. Some developments in this sense have been recently carried out by the international research and industrial community; however no well assessed coupling technology is available (or accessible) yet.

The present work consists of two parts. The first part is a review of the available literature on the subject, aimed at describing the state-of-the-art as far as the development and application of system-CFD coupling methods are concerned. The second part contains the outcomes of a practical demonstrative activity, namely: an explicit coupled tool is developed and tested against a simple pipe flow problem, showing good comparisons with stand-alone simulations. The main coupling issues are identified and future works are suggested for the development of a more robust and fully-featured tool. In general, the development of a CFD-system code coupling technique is proved to be technically feasible in the frame of a well supported mid-term research program.



1 Introduction

Over the past decades design and safety analysis of nuclear power plants have been carried out mainly using system codes (such as, for example, RELAP5, CATHARE, ATHLET, etc.) These computer codes are modelled as networks of 1-D or even 0-D elements and are based on a multi-fluid model of two phase flow supported by a very large database of mass, momentum and energy correlations, mainly formulated from 1-D special-effects experiments. However, for some components in the system, the flow is essentially 3-D and multi-dimensional effects have to be accounted for in order to properly simulate some scenarios. Three dimensional analysis is available in some system codes (RELAP-3D, CATHARE, etc.), but is prone to a number of restrictions related to nodalization, field equations, and other aspects of physical modelling, which making such codes not suited for the simulation of local phenomena such as mixing, natural convection, thermal striping, etc.

The need for deeper and more accurate investigation of accidental scenarios and the challenges posed by the design of GEN IV reactors have increased the interest of the nuclear community toward CFD codes during the last years. These codes are based on the Navier-Stokes equations and have been developed and used broadly to perform analysis of multi-dimensional flow, dominantly in non-nuclear industry and for single-phase flow applications. CFD codes have the potential to treat three dimensional flows where turbulence and complex geometries make system codes inappropriate. On the other hand CFD simulations have very high computational costs and cannot be used to replace system codes in the analysis of the whole system. A complex thermal hydraulic analysis requires different levels of simulations: from detailed component-level CFD simulations to integral system-level simulations.

Several research groups have recently been working on the development of coupling tools between system and CFD codes. Such tools are expected to greatly enhance the analysis capabilities of accident scenarios and to help better optimize the design of GEN IV reactors. Unfortunately most of the work is proprietary and is not easily accessible by the nuclear community. Coupling tools currently available in commercial codes have limited capabilities and lack versatility. For such reasons the development of a CFD-system code coupling tool has a great strategic value within the study of liquid metal reactors.

This report is made up of two main parts: in the first a literature review of the coupling between system codes and CFD codes is presented (Section 2), while in the second the first steps in the development of a coupling tool are given (Section 3), together with a simple demonstration case (Section 4).

2 Literature Review

This chapter describes a literature study of the state-of-the-art in the coupling between Thermal Hydraulic (TH) and Computational Fluid Dynamic (CFD) codes, sometimes referred to in the following as TH/CFD code coupling. Firstly, some general definitions are presented in Section 2.1. Then a literature overview is given in Section 2.2). Finally, Section 2.3 provides a comparison among the works found in the literature and a short summary.

2.1 Coupled systems classification

General methods of coupling are treated in several books and papers, e.g., Zienkiewicz (1984) [1], Hackbush and Wittum (1995) [2], Cadinu et al. (2007) [32] Wienan et al. (2003) [3] and Wienan (2007) [4] .

A coupled system consists of two or more distinct sub-systems where each sub-system is governed by its own set of differential equations but some of the variables are shared so that the sub-systems cannot be solved separately.

Following [1]:

“Coupled systems and formulations are those applicable to multiple domains and dependent variables which usually (but not always) describe different physical phenomena and in which:

- a) *neither domain can be solved while separated from the other;*
- b) *neither set of dependent variables can be explicitly eliminated at the differential equation level.”*

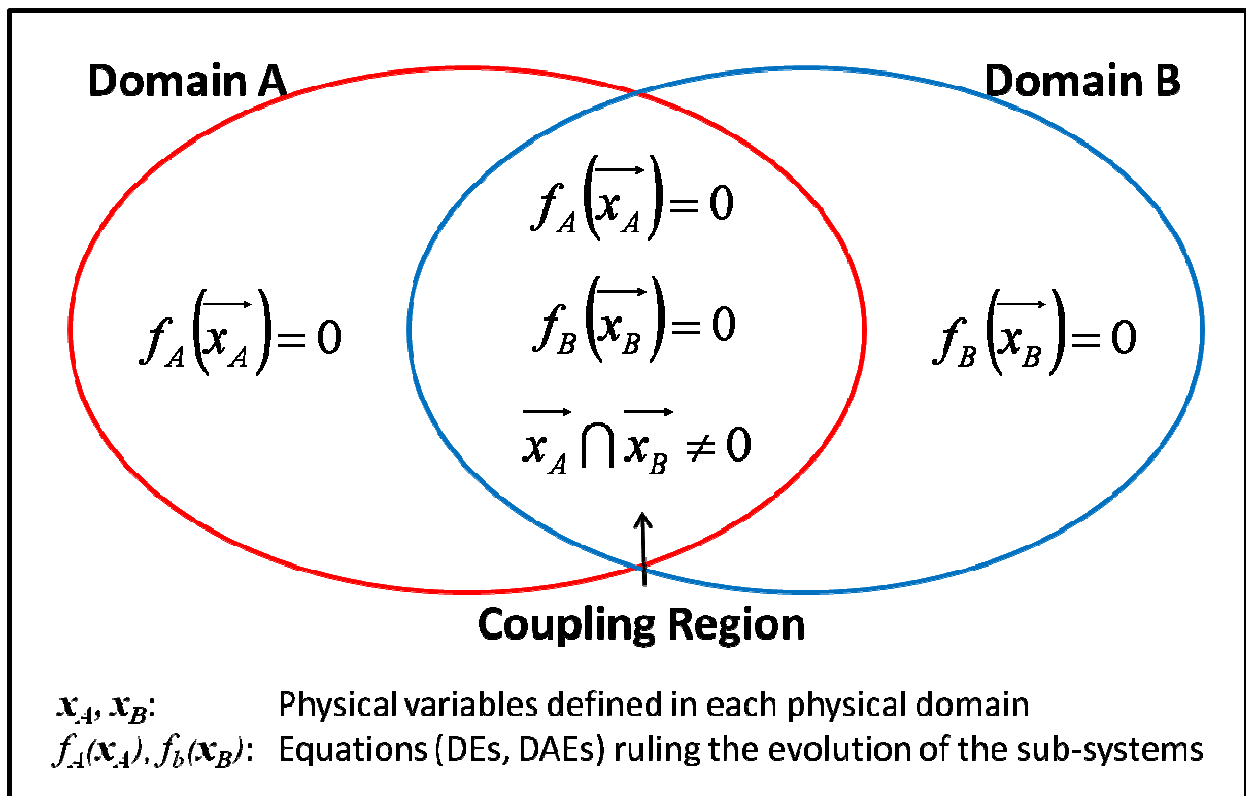

Figure 1: Example of Coupled System

For the sake of simplicity coupled systems composed of two sub-systems will be considered. The analysis of such systems can be easily extended to more than two coupled sub-systems. Figure 1 shows an example of a coupled system.



Each sub-system is defined in a domain. These domains describe the geometrical details (spatial domain) and the physical variables (physical domain) of each sub-system. A set of differential equations (DEs) or differential-algebraic equations (DAEs) rules each sub-system evolution in its domain. The coupling region is the common region where spatial and physical domains overlap (where geometric details are in common and some of the physical variables are shared). In this region both sets of differential equations have to be solved in order to get the solution for the entire coupled system.

In the coupling region the system of equation to be solved can be described by the following equations:

$$f_A(x_A, x_B) = 0$$

$$f_B(x_B, x_A) = 0$$

where:

x_A : Physical variables describing the first domain (domain A)

x_B : Physical variables describing the second domain (domain B)

f_A : differential/algebraic operator ruling the evolution of the first sub-system

f_B : differential/algebraic operator ruling the evolution of the second sub-system

The differential coupled system has to be discretized, if necessary both in time and space and solved numerically. Information has to be exchanged between the sub-systems at particular times called *synchronization points* and different types of approaches can be implemented to handle such transfer. The overall coupling strategy can be very different from one application to another. After collecting and merging definitions found in many sources in literature ([1], [5], [6], [7], [24], [37]), a possible classification of the different approaches is proposed:

The coupling between two codes can be classified according to:

- Spatial domains
- Coupling execution
- Code integration
- Synchronization
- Information exchange type
- Numerical scheme

The following sub-sections describe each class separately.

2.1.1 [Spatial domains](#)

As mentioned above, the coupled system is divided in computational domains (one for each code), geometrically such domains can be classified as:

- **Overlapping domains:** domains are spatially superimposed to some extent. In the common region results from one domain are usually used by the other as external sources or sinks. A possible example is:
 - *Thermal-Hydraulic/Neutron-Kinetic coupling inside a reactor core:* In this case the same region (reactor core) is modelled within the TH code to solve the flow field (temperature, void fractions, neutron poison concentration, etc..), such information is used by the Neutron Kinetic (NK) code to calculate the power to the coolant that in turn influences the flow field.
- **Non-overlapping domains:** the overall domain is split into separate regions divided by boundary interfaces (in this case the coupling region is such interface). Exchanged quantities have to be transferred through such boundaries and field equations are defined separately within each domain. A possible example is:
 - *TH/CFD coupling:* A complex system is modelled by the Thermal-Hydraulic code except for some particular components, modelled in CFD, where three dimensional flow and turbulence effects are important. Each code solves the flow field in its domain and boundary conditions in each code are provided by the other code. This creates a feedback effect, particularly strong in closed systems.

2.1.2 [Coupling execution](#)

An important distinction can be made about the connection between the executions of the coupled codes:

- **Off-line coupling:** codes are run separately and sequentially. Results from one code are used as boundary or initial conditions for the other. In this type of connection the coupling is very weak: the information transfer is only one way and no feedback is possible. The coupling strategy is very simple to implement and no modification of the codes is needed, on the other hand, this approach can't be used in problems where solutions in different domains are actually influenced by each other. Possible examples of this type of coupling are:
 - *Detailed structural analysis:* CFD results of the pressure field around a body are passed to a structural simulation to calculate stresses without any sort of feedback (the structural domain does not change shape so that the flow field is not influenced).
 - *Improved CFD boundary conditions:* Thermal-hydraulic system code results of a plant transient scenario are used by a CFD code as transient boundary conditions for a detailed simulation of a complex plant component (e.g. reactor pressure vessel): In this case the TH analysis is used only to provide boundary conditions to the CFD simulation, no feedback is studied.
- **In-line coupling:** codes run concurrently with a continuous exchange of information in both ways. The communication between codes has to be handled carefully in order to obtain a correct synchronization. Following the definition given above, coupled systems have to be treated in this way. A possible examples of this type of coupling is:
 - *Fluid Structure Interaction (FSI):* an example is the flutter phenomena (fluid-dynamic induced vibration on an elastic body). In this kind of problems the pressure field around the elastic body induces deformation in its structure that in turn induces variation in the flow (including the pressure field).

2.1.3 [Code integration](#)

Two approaches are possible:



- **Monolithic solution:** an ad hoc single solver whose purpose is to simultaneously solve the coupled systems is developed. Numerical schemes and algorithms can be tailored to the specific problem in order to increase the performance of the solution. Such an approach is usually more efficient but major modifications to the source of each code are required (if not a complete rewriting), hence validation of the single codes does not imply that the integrated code is validated. For this reason the monolithic integration doesn't allow the use of legacy software and is not very suitable for a modular approach (i.e. it is not easy to use the same code for different coupled problems).
- **Partitioned solution:** a solution method that couples independent solver (one for each domain) is employed. Usually a third external software (interface-software) is developed to handle the information exchange and the synchronization of the sub-systems while the solution within each sub-domain is left to the independent solvers. This approach is relatively simple and no (or very small) modifications of the source of each individual code are needed. Existing code-interface software can be used (PVM, MPI, etc.). Performance is usually reduced in respect of the previous case and the information transfer management can act as a bottleneck for computational time. On the other hand this approach is inherently modular and new models and numerical schemes can be easily introduced while keeping everything else unchanged.

2.1.4 Synchronization

This classification concerns only the partitioned approach, since in a monolithic solution there is only one code and all the information is known internally at every time step.

In a partitioned solution, data have to be transferred between the two independent codes in order to reach a coupled solution. Synchronization points are set where this transfer has to be done. Two approaches are possible:

- **Identical time steps:** a synchronization point is set every time step (being the same for each code). Such time step can either be set externally (fixed time stepping) or chosen by one of the codes (adaptable time stepping) and passed to the other. In the first case (fixed) both the codes know all synchronization points a-priori. In the second (adaptable) synchronization points are defined step by step. A more efficient time stepping is possible in the second case, but the receiving code has to wait for the sending one to choose the time step (not allowing for parallel coupling, as described in the next sub-section 2.1.5).
- **Sub-cycling:** each code makes its own time steps (sub-cycles) between two consecutive synchronization points. The motivation for sub-cycling may be the implementation of optimal settings for each solver concerning computational costs, stability and accuracy. For example, this approach is very useful when the characteristic time scales of the two sub-domains are quite different. In such case very different time steps can be chosen for the two codes allowing for a more efficient solution. Fixed or adaptable time stepping can be chosen for each code separately. An external control of the sub-cycles (usually performed by the interface-software) has to be made in order to ensure that both the codes reach the synchronization point exactly. In some cases a not exact synchronization point is allowed [7] but the solution is more prone to stability and accuracy issues.

2.1.5 Information exchange type

This classification concerns only the partitioned approach, since in a monolithic solution there is no need to exchange information (all the information is known internally).

Two different approaches are possible:

- **Sequential coupling:** one code is solved sequentially while the other remains idle waiting for information to continue the calculation. This approach is quite easy to implement but has longer computational times.
- **Parallel coupling:** codes work in parallel reducing dead times (especially when the two codes have comparable computational times). On the other hand the lack of a logical sequential order requires a careful choice on how to handle the exchanged information between synchronization points. This approach is more prone to instabilities.

2.1.6 Numerical schemes

In monolithic solutions, coupled systems are merged and the resulting system is solved internally to the code. The coupled system of differential equations has to be discretized both in time and space in order to obtain a set of algebraic equations that can be solved numerically. Discretization schemes to solve the resulting system follow the usual classification for systems of Ordinary Differential Equation (ODEs): discretization can either be *explicit* (solution at the current time step is a function of solution at previous time steps) or *implicit* (solution at the current time step is a function of previous and current time steps). A *semi-implicit* approach is also possible: the basic idea is to discretize a time dependent system of equations using an implicit scheme for some terms (evaluating such terms at current time) and an explicit scheme for the remaining terms (evaluated at previous times). Usually in this approach terms required for the fast solution components (short time scales) are treated implicitly while the slow solution terms (long time scales) are treated explicitly so that larger time steps can be used. Semi-implicit schemes are usually obtained combining in some way explicit and implicit schemes. These possibilities are schematized in the following general equations:

Explicit: $\mathbf{x}^{(n)} = \Phi(\mathbf{x}^{(n-1)})$

Implicit: $\mathbf{x}^{(n)} = \Phi(\mathbf{x}^{(n-1)}, \mathbf{x}^{(n)})$

Semi-implicit: $\mathbf{x}^{(n)} = \Phi(\mathbf{x}^{(n-1)}, \mathbf{x}_i^{(n)})$

where:

$\mathbf{x}^{(n)}, \mathbf{x}^{(n-1)}$: are the solution vectors at current and previous time steps respectively

$\mathbf{x}_i^{(n)}$: represents terms to be treated implicitly in the semi-implicit scheme

$\Phi(\ast)$: is the algebraic functional coming from the discretization process

- **Explicit monolithic methods** can be computed and solved directly from the solution at previous time steps, they are very easy to implement and use little computer memory and computation time per time step; unfortunately they can be unstable if the time step grows (i.e. CFL sonic limit). Accuracy can be better with respect to implicit schemes.
- **Implicit monolithic methods** usually require iterative solution to obtain the values at the new time step (if non-linear terms have to be computed at the current time step). This makes them harder to implement and they use more computer memory and time per time step. They are also usually less accurate and prone to some oscillation in the solution. On the other hand they are more stable and can have larger time steps with respect to the explicit schemes. For this reason in some application (stiff problems) these methods can have better computational performances than the explicit counterparts.
- **Semi-implicit monolithic methods** try to improve stability while maintaining in part the simplicity and accuracy of the explicit methods. The goal is to split up the terms in such a way that the largest stable time step for the semi-implicit discretization is significantly larger than for a corresponding explicit discretization, without sacrificing accuracy.



In a partitioned approach each independent code uses its own numerical schemes (*explicit, implicit, semi-implicit*), but an additional level of solution is introduced by the external exchange of information through the interface-software. For this reason, depending on how the exchanged data is treated, stability and accuracy problems may appear.

For the sake of simplicity of exposition it is assumed that both sub-systems have the same time step Δt (*identical time step*), however the following description can be easily extended to the case where there is sub-cycling between synchronization points.

It is important to emphasize that the following classification is related to the data exchange process, not to the numerical schemes of the single solvers. The possible numerical scheme in a partitioned coupled solution can be classified as:

- **Explicit coupling:** Solution of the previous time step is exchanged through the interface and used to resolve the new time step. It is very easy to implement and works well in parallel coupling. Convergence of results to a completely coupled solution is not guaranteed and discrepancies in exchanged values are possible, leading to global conservation issues. The single system solvers are most likely going to have an associated critical time step (i.e. Courant material limit, etc.), by coupling the systems (partitioned solution) in this fashion the critical time step for the coupled system will most likely decrease.

Following [5], the explicit coupling of two independent solvers can be expressed as (algebraic system after discretization):

$$\mathbf{x}_A^{(n)} = \Phi_A(\mathbf{x}_A, \mathbf{y}_B)$$

$$\mathbf{x}_B^{(n)} = \Phi_B(\mathbf{x}_B, \mathbf{y}_A)$$

where:

$\mathbf{y}_A, \mathbf{y}_B$: represents the influence of the other sub-system in the solution
subscripts A and B refer to the two sub-systems
all other symbols maintain the meaning described above.

If the parameters **\mathbf{y}_A** and **\mathbf{y}_B** are taken from the previous time steps as:

$$\mathbf{y}_B = \mathbf{x}_B^{(n-1)}$$

$$\mathbf{y}_A = \mathbf{x}_A^{(n-1)}$$

The fully explicit coupling is obtained:

$$\mathbf{x}_A^{(n)} = \Phi_A(\mathbf{x}_A, \mathbf{x}_B^{(n-1)})$$

$$\mathbf{x}_B^{(n)} = \Phi_B(\mathbf{x}_B, \mathbf{x}_A^{(n-1)})$$

It is interesting to note how the solution at the new time step is only dependent on the coupled solution at the previous time step (as in the explicit monolithic approach). This coupling scheme can easily be solved in parallel coupling since no information exchange is needed except for the values at the previous time step. For this reason this scheme can also be called *parallel explicit scheme*.

Some implicitness can be added to such scheme solving the system in a sequential fashion. In this case, first the solution for the new time step is calculated for one of the codes (code A), using old values. At this point, calculated values of the first sub-system variables can be used as educated guesses for the second code (code B). This improved scheme is called *sequential explicit scheme* and is still explicit, but some improvements in stability is achieved. The following relation describes this scheme:

$$\mathbf{x}_A^{(n)} = \Phi_A(\mathbf{x}_A, \mathbf{x}_B^{(n-1)})$$

$$\mathbf{x}_B^{(n)} = \Phi_B(\mathbf{x}_B, \mathbf{x}_A^{*(n)})$$

Semi-implicit coupling: Data exchange is treated implicitly (the semi-implicit in the definition refers to the data exchange). In some applications [5], [6] not all the exchanged data is treated implicitly, but only the most relevant for stability issues. The exchanged data, is re-calculated iteratively (coupling iteration) within the same time step until values converge for both the sub-systems. This scheme requires an external iterative algorithm (usually the task is performed by the interface-software) that makes the two codes iterate, updating exchanged data, until some convergence criteria is reached. Nested iteration can be present (if one of the code is implicit) and coordination between these two level of iteration is required (usually handled by the interface-software). This algorithms are more difficult to program and the external iterations increase the computational costs. The implicitness of the data exchange ensures conservation of the exchanged quantities through sub-systems, improving the stability of the solution. If both independent codes are implicit, results are completely equivalent to what would be achieved by a monolithic implicit formulation, although solution is achieved through a partitioned approach. The difference between the monolithic solution and the partitioned solution is that in the first one all the information is available inside the code while in the second one some information has to be calculated through external iterations across sub-systems (most probably increasing computational costs). Nested iterations are present: internal iteration for the implicit scheme of each sub-system and external iteration (coupling iteration) across sub-systems for the convergence of the exchanged quantities. Coordination between these iterations is required. In this case the coupling is difficult to program and a higher computational cost is required per time step. On the other hand the scheme is more stable permitting larger time steps; the global conservation of transported quantities is ensured through the coupling iteration. The following relation describes this scheme:

$$\mathbf{x}_A^{(n)} = \Phi_A(\mathbf{x}_A, \mathbf{x}_B^{(n)})$$

$$\mathbf{x}_B^{(n)} = \Phi_B(\mathbf{x}_B, \mathbf{x}_A^{(n)})$$

2.2 Literature overview

In this section an overview of the literature about the coupling between system codes and CFD codes is given. The various sources are presented in a sort of chronological order, however, some extensive works incorporating several papers and publications from same authors, written along a wide period are covered altogether. In the last part a very short list of 1D / 3D coupling works outside the nuclear field is given.

One of the first attempt to couple a 1D TH code with a 3D hydro-dynamic code can be found in Lee et al (1992) [8]. In this paper the development of a new tool, called COBRA/RELAP5 code, that merges the capabilities of RELAP5/MOD3 and COBRA-TF, is described. This work follows somehow a monolithic approach (see Section 2.1.3), which might cause issues of maintainability. Major modifications for the two coupled codes were carried out, even if the inherent features of each code were maintained, for this



reason a systematic assessment should be done in order to evaluate the overall code predictability. Some tests were presented in this first paper, while an assessment campaign was undertaken in following papers, Jeong et al (1997) [9] and (1999) [10], where simulations are validated against the LOTF L2-3, Prassinios (1979) [11] and L2-5, Bayles and Divine (1982) [12]) Large Break LOCA experiments and the FLECHT-SEASET test 31805, Paik 1986 [13] among the others. These experiments are two-phase flow applications. In general predicted values agree reasonably well with experimental data except for some local errors. In particular an improvement with respect to a RELAP5 stand-alone simulation is found. Such efforts brought to the development of the multi-dimensional thermal-hydraulic system code MARS [10].

In U. Graf (1998) [14] the importance of the numeric scheme is discussed. A comparison between explicit and implicit treatment of the equations is shown and an implicit method based on the fractional step method is proposed. The method is validated against experimental data, test 6 run 136 of the Upper Plenum Test Facility, P. Weiss (1986) [15], using a coupling between a custom two-dimensional FLUBOX module and the ATHLET system code. The need of an implicit treatment for an efficient analysis of the chosen scenario is underlined, with the explicit method consuming seven times the computational time of the implicit one.

An example of an off-line coupling (see Section 2.1.2) is given in S. Kliem (1999) [16]. In this paper the off-line coupling between 1D system code ATHLET, 3D CFD code CFX-4 and the 3D-neutron kinetic code DYN3D is described. The system code calculations provide boundary conditions for the CFD code that in turn solve the temperature distribution to be used in the neutronic code. With such approach a Main-Steam-Line-Break (MSLB) analysis for the VVER-440/V-230 is presented and compared with analytical models and experimental measurements, Dräger, (1987) [17]. This off-line coupling approach gives improvements in prediction capabilities, allowing for a reduction in the conservative approach of no mixing inside the Reactor Pressure Vessel (RPV).

An example of extensive research in the field of code coupling is the development of the methodology for coupling RELAP5 and RELAP5-3D codes to different codes by D.L. Aumiller, W.L. Weaver and R.R. Schultz.

In Aumiller (2001) [18] the problem is first proposed. In this paper a proof-of-principle calculation is performed using the Edwards-O'Brien depressurization experiment: Edwards, O'Brien (1970) [19]. Comparisons between RELAP5-3D stand-alone, RELAP/RELAP homogeneous coupling, CFD stand-alone and RELAP/CFD coupling are presented and analyzed qualitatively. No comparison with experimental data is shown in the paper. The coupling was between RELAP5-3D and CFDS-FLOW3D (now CFX). Numerical instabilities are observed in the coupled simulations with respect to the stand-alone ones and are attributed to the explicit coupling algorithm. In order to solve this issue a semi-implicit algorithm is developed and described in Weaver (2002) [20] and Aumiller (2002) [21]. In the first paper, [20], the semi-implicit approach is described in some details. Systems are divided in a master and a slave process. RELAP5-3D is set as the master and the pressure changes within all the master system volumes are expressed as linear functions of the yet unknown mass and energy fluxes at the coupling interfaces. Coefficients in these linear relations at the interfaces are transmitted to the slave process in order to solve simultaneously the flow field and the exchanged fluxes in its own sub-domain. Finally the exchanged fluxes are used to solve the flow field in the master sub-domain. This approach is quite different to the semi-implicit methods described in Section 2.1.6. Coupling iterations are not needed, but the solving algorithms of the two codes have to be strongly modified in order to be able to handle variables in the form of linear functions of exchanged fluxes. For this reason this approach can be in part considered as a monolithic solution. A verification of the semi-implicit algorithm is performed using a modified version of the run 15 of the Christensen sub-cooled boiling experiments: Christensen (1961) [22]. A homogeneous RELAP / RELAP coupling is tested for simplicity. The qualitative analysis is carried out comparing a RELAP stand-alone simulation with the coupled one. Unlike the explicit test [18], in this case no difference between stand-alone and coupled simulation is found. The quantitative comparison shows very good agreement against

experimental data. The effect of different equation of state (EOS) is mentioned as a possible cause to temperature discontinuities across the coupling interface in order to preserve the mass and energy conservations. In the second paper [21] a RELAP / CFD coupling is tested with the same experimental data. The CFD code is again CFDS-FLOW3D (now CFX). In addition to the previous case, a description of the implemented algorithm for the CFD part (slave process) is given. Strategies for the information transfer, for the different phase exchange and 1D / 3D profiles are presented. In Weaver (2002) [23] a sequential explicit algorithm is developed in order to solve instability issues found in [18] while retaining an explicit numerical scheme. This is done by imposing mass and energy conservation through the time steps. The resulting method is quite similar to the sequential explicit scheme described in Section 2.1.6, it has improved stability when tested against the same experiments described in [18]. In order to coordinate the coupling between different codes in a more structured way, an executive program, PVMEXEC, is described (but already used in previous works) in Weaver (2005) [24].

Following these works, Idaho National Laboratory (INL) has started a project aimed at the coupling of its in-house code RELAP5-3D (system code derived from the 1D code RELAP5) with the commercial CFD code Fluent. In Schultz (2002) [25] the coupling code is described and a verification and validation matrix is constructed in order to check such a tool. Possible coupling with neutronics is also underlined, since the RELAP3D/ATHENA code has neutronic subroutines. In Schultz (2002) [26] a simple verification on a single phase problem is presented, unfortunately results are not available in the paper. The main scope of the code is the application to single phase scenarios: Very High Temperature Reactors (VHTRs), Gas cooled Fast Reactors (GFRs), lead-cooled reactors and liquid-sodium reactors. In the paper the possibility to extend the use to two-phase flows, typical Liquid Water Reactors (LWRs) applications, is presented. In Schultz (2005) [27] a description of the complete set of tools for the evaluation of VHTRs plants behaviour is presented. The paper describes also tests, relevant phenomena and software to be used. Some application examples are shown but no result is available. In particular an application to mixing in the prismatic lower plenum of a VHTR is presented (no results available). Some more details of such simulation are given in Anderson (2006) [28] where the developed tool is used to simulate the mixing. Unfortunately, the results could not be validated against experimental data, thus making this effort principally a verification case. Also in this case the influence of different state equations (EOS) is outlined as a possible source of errors.

The influence of the transition between 1D and 3D description at the interface is studied in Gibeling & Mahaffy (2002) [29]. The test case studied is compared with Laufer's pipe flow experiments: Laufer (1953) [30]. Application of uniform profiles for transmitted quantities at the interface leads to inconsistencies in the pressure distribution along the simulated pipe. Such inconsistencies disappear if a fully developed profile is used instead (in the 3D part of the coupling). The paper also suggests possible issues in code coupling such as interaction of spatial and temporal difference methods in the two regions, implicitness of the coupling between regions, significance of consistent wall terms and state equations, distribution of mean 1-D variables over the connecting surface for use by the 3D calculation and finally averaging methods to extract 3-D information for use by the 1-D calculation.

The influence of different equations of state is also investigated in Ambroso et al. (2005) [31], where a 1D flow region is divided in two sub-regions described by the same differential equations but with slightly different equation of state. This situation can lead to global conservation problems and erroneous solutions, especially in the case of two phase flows.

In Cadinu et al (2007) [32] after a brief review of the past coupling activities, possibility to use multi-scale methods [3] and [4], to couple system codes and CFD codes is suggested.

An IAEA document [33] presents a brief and general description of code coupling in nuclear reactor safety.

In Yizhou (2008) [34] a coupled CFD/System code is developed. The two codes used are RELAP5 and Fluent. In the paper the importance of the numerical scheme is stressed. The code uses a semi-implicit approach. Verification of the code is pursued through a simple unsteady pipe flow problem and then with an application to a typical transient scenario of a PWR. No validation against experimental data is done. The same approach is used in Yizhou (2011) [35] where the coupled code is adopted to simulate a Gas Turbine – Modular Helium Reactor (GT – MHR). Again this is a sort of verification test where the potential of the coupled system is demonstrated, but no validation against experimental data is done.



A coupled TH / CFD tool is presented in Bertolotto (2008) [36], the two codes used are TRACE and ANSYS CFX. Two different numerical schemes are implemented: sequential explicit coupling and sequential semi-implicit coupling. A first verification testing is done with a very simple geometry. The water flow within a 3 m long pipe of internal diameter of 50 mm is simulated; the first two meters are modelled with TRACE and the last one with CFX. Different numerical schemes and time steps were tested in order to study convergence and stability issues. In this case both numerical schemes give the same results. The use of a flat velocity profile in the CFX part introduces deviation in pressure drops along the pipe due to the developing turbulent velocity profile. After this verification exercise, the tool is tested with a double T-junction mixing experiment carried out at the Paul Scherrer Institute (PSI). The result shows good comparison with the experimental data and the improvement with respect to the TRACE stand-alone solution is underlined. A more detailed coverage of this work can be found in Bertolotto (2011) [37]. In this work, the code development is described and two verification tests are analyzed: an open loop configuration (the same described before) and a closed loop one consisting in an 11 m loop with internal diameter of 50 mm. The simulations were conducted on simple pipe geometry. From these verification tests the importance of the exchanged variables profiles is underlined. Semi-implicit schemes, while more accurate than explicit ones, seems to show convergence problems when larger time steps are used. In the closed loop tests however, the semi-implicit scheme is less prone to unphysical solution oscillations than the explicit scheme. The code is also validated against two different experiments: the first is the double T-junction mixing experiment described above, the other is a scaled down, simplified, two-dimensional vertical slice of a LWR vessel (FLORIS). From these validation tests the following conclusions can be drawn: coupled simulations provide an improvement over stand-alone TRACE simulations; the effect of velocity profile is very important to correctly predict the mixing effects in the experiments; the consistency of the exchanged quantities at interface is important to obtain good results. Comparison with the second experiment shows some problem probably due to the deficiencies of RANS turbulent models when treating complex geometries.

ANSYS and GRS made some efforts to couple the GRS system code ATHLET with the CFD code ANSYS CFX. In Waata (2008) [38] a detailed description of the development of the coupling interface between the two codes is presented. Three verification tests are then analyzed: an ATHLET-PIPE/CFX-PIPE test on a horizontal pipe, an ATHLET/CFX/ATHLET configuration for a horizontal pipe and a closed system. Results are compared to the stand-alone solutions of the two codes. Also a reverse flow case verification is studied. Closed system tests show pressure deviation from the set system pressure despite the small mass imbalances. Some explanation of this behaviour is connected with the almost incompressible nature of the working fluid. In order to solve this issues, in Papukchiev (2009) [39] a review of the working fluid and equation of state of both the codes was carried out and a consistent mass flow-velocity conversion between the interface is developed in order to further reduce mass imbalances. With these modifications stable pressure over time even for closed loop configurations is obtained. Some problems still remain due to the explicit numerical schemes used for the coupling. The work then proceeded within a NURISP project. A semi-implicit scheme is developed and described in Papukchiev (2010) [40] in order to enhance the stability of the coupled system. Verification of this improved tool is described in Papukchiev (2011) [41] where the improved stability is demonstrated. The paper outlines how in some cases calculations with the semi-implicit scheme can be more efficient in terms of CPU time, due to the larger time steps that can be reached during an adaptive time stepping approach. A validation example is finally presented in Papukchiev (2011) [42], where the coupling tool is tested against the Large Scale Test Facility ROSA V experimental data. Such experiment investigates the thermal stratification at single-phase natural circulation and cold ECC injection in the cold leg of a PWR. Coupled results are compared with measurements of temperature at two different positions. Comparison with experimental data shows good agreement for one position while larger deviations are predicted for the other. Possible reasons are identified in insufficient geometry modelling or inadequacy of turbulence models adopted. Within the same NURISP project a verification of

the coupling between system code CATHARE and the CFD code TRIO-U is presented in Vysocil (2011) [43] . The test is based on the MSLB accident described in Meca et al. (2005) [44] . It was demonstrated that the coupled system can be used to simulate the coolant mixing in the downcomer and the flow reversal in the afflicted loop during the Main-Steam-Line-Break event.

The following works are studies on coupling 1D codes and CFD outside the nuclear field.

In Zhiqiang 2003 [45] , the coupling between an Energy Simulation (ES) code and a CFD code is presented. The coupling is used to study building energy balance and indoor environment design. The 1D code (the ES code) solves the heat balance equations for building enclosures while the CFD code is used to model the internal flow. The convective heat transfer on the interior surfaces links ES and CFD. ES provides space heat extraction rate and enclosure thermal information to CFD as inlet and surface boundary conditions, while CFD provides accurate interior surface convective heat transfer to ES. In this work a detailed analysis on solution existence, uniqueness of ES/CFD coupling and stability is carried out. Different strategies of data transfer are proposed and studied. The coupling code is verified with a simple example (cubic room ventilation).

Internal Combustion Engines (ICEs) are studied in Bella 2003[46] and Galindo 2010 [47] . In the first paper [46] , a coupling between the in-house 1D code SIM1D and the CFD code KIVA is proposed. The KIVA software predicts complex fuel and air flows as well as ignition, combustion, and pollutant formation processes in engines. After a description of the in-house 1D code capabilities and models, the coupling strategy is described (very similar to an explicit coupling) and a simulation of a gasoline direct injection, 4 cylinders with 1.6 litres Fiat engine is illustrated. The intake plenum and cylinders are modelled with the CFD code while the remaining components of the system are simulated with the 1D code. This case is presented as a validation test, even if experimental data comparison is not given in the article. In the second paper [47] , a coupling methodology based on the Method of Characteristic (MoC) is presented. After a brief description of the MoC and the modifications needed to use it in non-homoeotropic flows the implemented coupling between OpenWAM and the CFD code Fluent is presented. OpenWAM is an open source one-dimensional gas dynamic model able to calculate the air and gas flows within the intake and exhaust systems of internal combustion engines. Implementation of the MoC requires manipulation of the Fluent code using User Defined Functions (UDFs) available within the code in order to define the Riemann invariants in the CFD sub-domain. The coupling is validated against an analytical solution (Sod's problem, [48]) and against an impulse test rig experiment. Results show good comparison with experimental data.

A general coupling interface MpCCI (Mesh-based parallel Code Coupling Interface) is developed by the Fraunhofer Institute SCAI. This tool provides an application independent interface for the coupling of different simulation codes. Some of the applications are: Fluid Structure Interaction (FSI), thermal coupling and general 1D-3D code coupling. Two different CFD codes can be used in the 1D-3D coupling, Fluent and STAR-CCM, while only Flowmaster is available at the moment for the 1D part. A general description of the MpCCI code is given in Wolf 2007 [49] while some applications specific to the 1D/3D coupling are given in the MpCCI manual [7] and in a presentation of the STAR European Conference 2010 [50] . In this last work, the coupling between Flowmaster and STAR-CCM+ is used to analyze the air distribution system and the cabin heat load of a large aircraft.

2.3 Comparison and summary

Table 1 shows a comparative summary of the main works found in the literature. In particular, reference is provided to the verification and validation (V&V) databases adopted to the code qualification.



Table 1: Comparison between works found in literature

Work	Year	Coupled Codes (1D / 3D)	Main Features	V & V
Lee & Jeung [8],[9],[10]	1992 - 1999	RELAP5/COBRA	<ul style="list-style-type: none"> Nearly Monolithic Semi-implicit (monolithic) 2Φ-flow applications Brings to MARS code development 	Validation against: <ul style="list-style-type: none"> LOTF L2-3 [11] LOTF L2-5 [12] FLECHT-SEASET [13]
U. Graf [14]	1998	ATHLET/FLUBOX	<ul style="list-style-type: none"> Explicit Vs Implicit coupling Implicit Fractional Step Method 	Validation against: <ul style="list-style-type: none"> UPTF [15]
Kliem [16]	1999	ATHLET/CFX-4 + DYN3D (NK)	<ul style="list-style-type: none"> Off-line coupling 	Comparison with analytical model and experimental data: <ul style="list-style-type: none"> MSLB of VVER-440/V-230 [17]
Aumiller, Weaver [18],[20],[21],[23] Schultz et al. [25],[26],[27] Anderson [28]	2001 – 2002 2002 – 2005 2006	RELAP5-3D/CFDS-FLOW3D RELAP5-3D/Fluent RELAP5-3D/Fluent	<ul style="list-style-type: none"> Works mainly from INL Explicit, Semi-implicit coupling Sequential explicit coupling Importance of EOS 	Verification on simple examples Validation against: <ul style="list-style-type: none"> Edward O'Brien Test [19] Christensen boiling tests [22] Simulation of mixing in VHTR
Gibeling [29]	2002	FLOW1D/NPHASE	<ul style="list-style-type: none"> Study of exchanged data profiles Remarks on possible issues 	Validation against: <ul style="list-style-type: none"> Laufer experiments [30]
Yizhou [34],[35]	2008 - 2011	RELAP5-3D/Fluent	<ul style="list-style-type: none"> Semi-implicit coupling 1Φ-flow applications 	Simulation tests on transient scenarios of PWR and GT - MHR
Bertolotto [36],[37]	2008 - 2011	TRACE/CFX	<ul style="list-style-type: none"> Explicit and Semi-implicit coupling Importance of interface profiles 	Verification on simple examples Validation against: <ul style="list-style-type: none"> Double T-junction mixing [37] FLORIS [37]
ANSYS-GRS Waata, Papukchiev [38],[39],[40],[41],[42] Vyscocil [43]	2008 – 2011 2011	ATHLET/CFX CATHARE/TRIO-U	<ul style="list-style-type: none"> Explicit and Semi-implicit coupling Importance of EOS 	Verification on simple examples Validation against: <ul style="list-style-type: none"> ROSA V MSLB of VVER-1000 [44]

The considerable amount of work performed in the direction of coupling CFD and system codes in the last years shows the interest of the nuclear community in developing a tool that can analyze complex systems with appropriate accuracy and affordable computational costs.

A common feature of the examined literature is to decompose the computational domain in order to use CFD tools only in selected sub-domains where 3D phenomena, complex geometry and turbulence have a main role, leaving the majority of the system to be analyzed by the system code. Most of the works choose a partitioned approach, where the solution of sub-systems is left to dedicated software while an interface code is developed to manage the exchange of information between sub-domains. Partitioned solutions are preferred for the increased versatility: they are more suited for modular approaches, commercial and proprietary software can be used and new versions of such codes can easily be integrated in the coupling tool without major modifications. Two exceptions to this general tendency are works by Lee and Jeong ([8], [9] and [10]) and part of the work by INL ([20] and [21]). In both cases the inherent features of the coupled codes are maintained but strong modifications in the sources are needed. The importance of the numeric coupling scheme is often addressed and considerable efforts are made to develop robust and physically consistent exchange of information.

In order to improve the stability of the coupled simulation, usually an external coupling iteration is carried out until converged values of the exchanged data are found. In this way current time, consistent values of boundary conditions are used to solve the current time step in an implicit fashion. A different approach is adopted in [14], where a fractional step method is proposed to add implicitness to the coupling and in [20], where the exchange of consistent data is obtained by linking the two sub-systems with linear relations of the transported fluxes. Detailed description of the numerical schemes is seldom encountered and it is the opinion of the authors that a great part of the information is proprietary and difficult to gather in literature.

Independently of the details of the particular coupling strategy, validation and assessment of the coupled code is required. The individual codes usually solve problems with different spatial and time scales and, particularly in the case of a strong two-way coupling, it is not enough to validate or assess the codes individually. A validation against simple experimental data is presented in [18], [21], [29], [37]. Some numerical tests and verification exercises are given in [36], [37], [38], [39], [40], while simulations and applications to real plant scenarios are available in [34], [35], [28] (without comparison to experimental data). Validation against experimental data of relevant scenarios are illustrated in [9], [10], [14], [37], [41], [42], [43], but often experimental comparison is rather poor, probably due to the inadequacy of the turbulent models adopted in the CFD part of the simulation.

A complete and systematic assessment is not available in the examined literature, even if suggested in [9] and [25]. In order to develop a reliable coupling tool, different identified issues have to be investigated independently and then a validation against more complicated phenomena and real plant scenarios should be pursued for a complete assessment. A list of possible coupling issues is presented below following mainly the ones suggested in [29].

- **NON-UNIFORMITIES BETWEEN COUPLED SUB-DOMAINS:**

- *Grids*: large differences in grid size, especially in the direction normal to the coupling interface, can introduce inaccuracies in the results
- *Numeric schemes*: completely different numeric schemes (both in order and implicitness) can affect stability and accuracy of the results
- *EOS*: different Equation Of States can lead to unbalances in the conservation equations, if main variables like velocities and pressures are transferred, or discontinuities in variables across the interface, if global conservation is imposed (see [20], [31])
- *Physical models*: different models (turbulence, two phase flow correlations, etc.) can bring to unphysical solutions
- *Variable arrangement*: if staggered arrangement is used in one sub-domain (usually system code) and collocated in the other (usually CFD code), discrepancies in variable values can introduce



CIRTEN

Consorzio Interuniversitario per la Ricerca TEcnologica Nucleare

inaccuracies, especially in the case of different grid size in the direction normal to the boundary interface.

- **COUPLING SCHEMES**

- *Explicit / Semi-implicit / Implicit*: careful choice of the suitable numerical scheme is important to control stability and accuracy issues. Unbalances in the conservation equations may rise in explicit coupling schemes. The right level of implicitness is usually problem dependant.

- **DATA INCONSISTENCIES**

- *3D to 1D*: suitable averaging methods should be studied to extract 3D information for use by the 1D calculation
- *1D to 3D*: distribution of mean 1D variables over the connecting surface for use by the 3D code is crucial for a correct simulation (see [29] and [37])

- **PARALLEL COMPUTING**

In order to take advantage of multi-processor capabilities and to reduce the computational time, parallel computing can be utilized. Access to the partitioned memory allocation for the coupled codes is necessary and care must be taken in the development of the external coupling interface in order to handle data transfer correctly and efficiently.

3 Code Coupling Development

This chapter describes the first steps in the development of a in-house coupling tool between a system code and a CFD code. Section 3.1 presents the main features of the codes employed in the development of the coupled tool, while the strategy adopted for the coupling is discussed in Section 3.2.

3.1 Selected Codes

For the present creation of a coupling tool, commercial codes available and regularly used at GRNSPG are chosen, in particular RELAP5 and RELAP5-3D as the system code and ANSYS CFX as the CFD code. The following sections give a brief description of such codes.

3.1.1 RELAP5

The RELAP5 series of codes has been developed at the Idaho National Laboratory (INL) under sponsorship of the U.S. Department of Energy, the U.S. Nuclear Regulatory Commission, members of the International Code Assessment and Applications Program (ICAP), members of the Code Applications and Maintenance Program (CAMP), and members of the International RELAP5 Users Group (IRUG). Specific applications of the code have included simulations of transients in light water reactor (LWR) systems such as loss of coolant, anticipated transients without scram (ATWS), and operational transients such as loss of feedwater, loss of offsite power, station blackout, and turbine trip. RELAP5-3D, the latest in the series of RELAP5 codes, is a highly generic code that, in addition to calculating the behavior of a reactor coolant system during a transient, can be used for simulation of a wide variety of hydraulic and thermal transients in both nuclear and nonnuclear systems involving mixtures of vapor, liquid, non-condensable gases, and nonvolatile solute.

The RELAP5-3D code is based on a non-homogeneous and non-equilibrium model for the two-phase system that is solved by a fast, partially implicit numerical scheme to permit economical calculation of system transients. The objective of the RELAP5-3D development effort from the outset was to produce a code that included important first-order effects necessary for accurate prediction of system transients but that was sufficiently simple and cost effective so that parametric or sensitivity studies were possible.

The code includes many generic component models from which general systems can be simulated. The component models include pumps, valves, pipes, heat releasing or absorbing structures, reactor kinetics, electric heaters, jet pumps, turbines, separators, annuli, pressurizers, feedwater heaters, ECC mixers, accumulators, and control system components. In addition, special process models are included for effects such as form loss, flow at an abrupt area change, branching, choked flow, boron tracking, and non-condensable gas transport.

The system mathematical models are coupled into an efficient code structure. The code includes extensive input checking capability to help the user discover input errors and inconsistencies. Also included are free-format input, restart, renodalization, and variable output edit features. These user conveniences were developed in recognition that generally the major cost associated with the use of a system transient code is in the engineering labor and time involved in accumulating system data and developing system models, while the computer cost associated with generation of the final result is usually low.

3.1.2 ANSYS CFX

According to the software documentation [51], "ANSYS CFX is a general purpose Computational Fluid Dynamics (CFD) software suite that combines an advanced solver with powerful pre- and post-processing capabilities."

The set of equations that describes the processes of momentum, heat and mass transfer in fluid dynamic problems are known as the Navier-Stokes equations. Such set of equations is solved numerically by ANSYS CFX after a discretization process. Equations describing other processes, such as combustion, can also be



solved in conjunction with the Navier-Stokes equations. Often, an approximating model is used to derive these additional equations, turbulence models being a particularly important example.

There are a number of different solution methods that are used in CFD codes. The most common and the one on which CFX is based is known as the finite volume technique. Governing equations are integrated over each finite control volume. Approximation of the integrals leads to a set of discretized equations that ensure local and global conservation of the transported quantities. The discretized equations are then solved iteratively using a coupled solver, in which all the hydrodynamic equations are solved as a single system. The coupled solver is faster than the traditional segregated solver (where the momentum equation is solved first, using a guessed pressure, and an equation for a pressure correction is obtained afterwards) and fewer iterations are required to obtain a converged flow solution. The numerical scheme adopted is fully-implicit, first or second order methods can be chosen for both time and space discretization in order to improve stability or accuracy performances. The main modelling capabilities of ANSYS CFX are listed below:

- Steady-state and transient flows
- Laminar and turbulent flows
- Subsonic, transonic and supersonic flows
- Heat transfer and thermal radiation
- Buoyancy
- Non-Newtonian flows
- Transport of non-reacting scalar components
- Multiphase flows
- Combustion
- Flows in multiple frames of reference
- Particle tracking.

Since turbulent flows at realistic Reynolds number would generally involve length scales much smaller than the smallest finite-volume mesh which can practically be used in numerical analysis, turbulence modelling is needed to solve fluid dynamic problems without recourse to prohibitively fine mesh. ANSYS CFX offers quite a wide range of turbulence models.

One approach is based on the statistical averaging of the Navier-Stokes equations. The resulting set of equations is called Reynolds Averaged Navier-Stokes equations (RANS). A number of models have been developed which can be used to approximate turbulence based on the RANS equations in CFX. Some have very specific applications, while others can be applied to a wider class of flows with a reasonable degree of confidence. The models can be classified as either eddy-viscosity or Reynolds stress models. The first ones assume that the influence of turbulence can be modelled to be proportional to mean velocity gradients, in a manner analogous to the relationship between the stress and strain tensors in laminar Newtonian flows. Within this approximation, two-equation turbulence models are widely used, where turbulence energy and length scales are solved using separate transport equations. The $\kappa - \epsilon$ and $\kappa - \omega$ models and their derivative models (e.g. the SST model) fall in this category. In Reynolds stress models transport equations for all components of the Reynolds stress tensor and dissipation rate are solved. Such models naturally include the effects of streamline curvature, sudden changes in the strain rate, secondary flows or buoyancy, compared to turbulence models using the eddy-viscosity approximation. As a drawback these models are more complicated, usually prone to instabilities and have higher computational costs. Theoretically, Reynolds Stress models are more suited to complex flows, however, practice shows that they are often not superior to two-equation models.

A different approach, called Large Eddy Simulation (LES), is based on spatial filtering of the Navier-Stokes equations where the large or resolved scale field, the one to be simulated, is essentially a local average of the complete field. Again the resulting set of equations is not closed and turbulence modelling is required. The main difference with respect to the RANS based models is that the unresolved field (small turbulence structures or eddies), which has to be modelled, is assumed to have little energy content and quite a general structure, weakly problem dependant. The filtering process in LES simulations requires the grid size being comparable to the smallest eddies to be resolved. For this reason LES simulation have higher computational costs than RANS.

The main models available in ANSYS CFX are listed below:

- RANS MODELS
 - Eddy Viscosity Models:
 - Standard $\kappa - \varepsilon$ model
 - RNG $\kappa - \varepsilon$ model
 - Standard $\kappa - \omega$ model
 - Baseline (BSL) zonal $\kappa - \omega$ model
 - SST zonal $\kappa - \omega$ model
 - $(\kappa - \varepsilon)_{1E}$ model
 - Curvature correction for two-equation models
 - Reynolds-Stress Models
 - Reece and Rodi Isotropization of Production model (LRR Reynolds Stress)
 - Launder, Reece and Rodi Quasi-Isotropic model (QI Reynolds Stress)
 - Speziale, Sarkar and Gatski (SSG Reynolds Stress)
 - SMC-w model (Omega Reynold Stress)
 - Baseline (BSL) Reynolds Stress model
 - Explicit Algebraic Reynolds Stress Model (EARSM)
- Large Eddy Simulation (LES)
- Hybrid Models (RANS – LES)
 - Detached Eddy Simulation (DES)
 - Scale Adaptive Simulation (SAS)

The DES and SAS are models that somehow merge the RANS and LES approaches in order to be able to finely resolve the turbulence structure in a LES way when needed while retaining the simpler and less costly RANS approach in the remaining flow regions.

To add additional features and physical models to CFX, it is possible to write subroutines in FORTRAN and have the CFX-Solver call them through a source code interface. CFX supports user subroutines written in FORTRAN 77 or FORTRAN 90. These allow the user to access the Memory Management System (MMS) of the code, thus giving a very fine control over the simulation, access to resolved field variables and allowing the introduction of almost any external user-made code. Two kinds of routines are available: User defined CEL (CFX Expression Language) functions that can be used to introduce user defined functions in addition to the predefined ones available in CFX and Junction Box Routines that can be called at several points during the solution in order to perform tasks defined by the user. These features are essential for the creation of a coupling with external codes.



3.2 Coupling strategy

The use of proprietary codes does not allow access and modification of the source codes, for this reason the choice is restricted to a partitioned approach. This is not necessarily a bad point, given the improved versatility and modularity (as described in Section 2.1.3). Moreover, some manipulation of the CFD code is possible through the User FORTRAN interface as described in Section 3.2.1, while data transfer and handling in RELAP5 can be carried out using control variables.

Since a very simple demonstration case is requested, a simple sequential, explicit coupling is chosen where interface data is written in text files and transferred through Input / Output (I/O) routines. Such an approach is less efficient with respect to a direct memory data transfer, on the other hand it is easier to develop and I/O computational times are considered unimportant compared to CFD ones. Identical time stepping and sub-cycling methods are both implemented (see Section 2.1.4), also fixed and adaptable time steps can be chosen. Many variables are made available for data transfer in order to permit a wider and more versatile use of the coupling tool. Currently parallel computing is not allowed; implementation of such feature together with more robust coupling schemes and, if needed, with a more efficient data transfer are left to future works.

In Figure 2 a schematic sketch of the coupling strategy is shown. Data to be exchanged are taken from (and transferred to) boundary interface of the CFX system and Time Dependent Volumes (TDV) or Time Dependent Junctions (TDJ) in the RELAP domain. Such data are then written in (and read from) text files through I/O routines. CFX subroutines can deal with data transformation in order to ensure consistency of transferred values if needed.

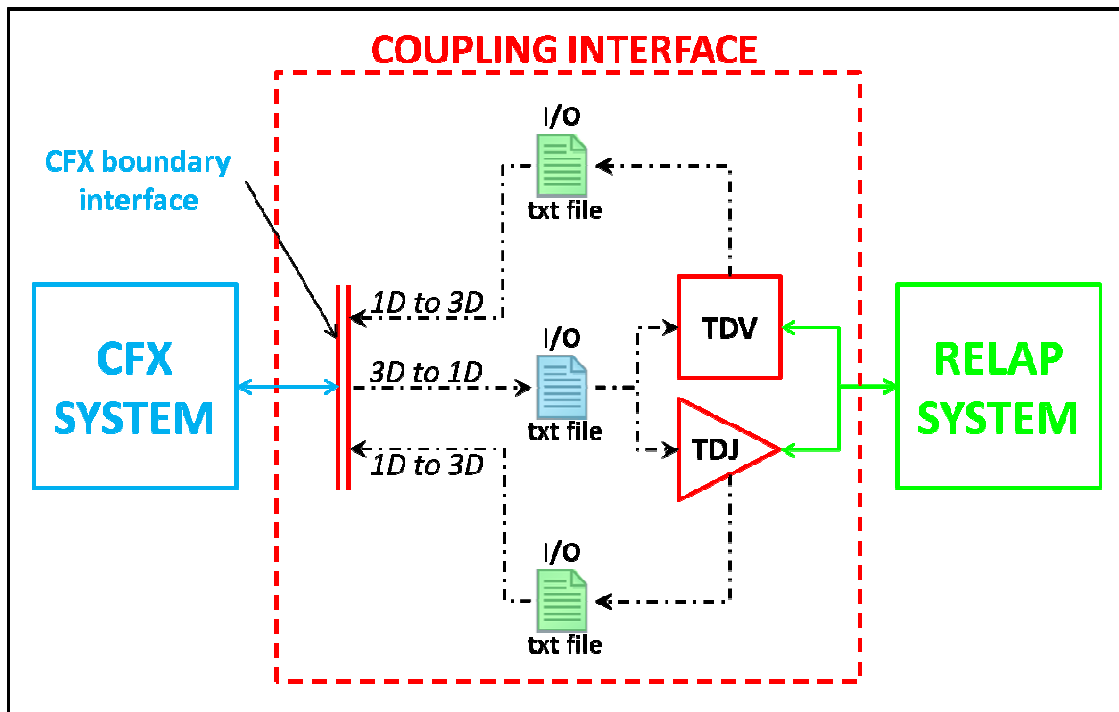

Figure 2: Coupling Strategy Sketch

An external PERL script is developed to handle the coupled simulation. It starts both sub-codes and handles I/O functions for the RELAP part. The I/O routines for the CFD part are written in FORTRAN and compiled within CFX in order to have a more direct access to the internal Memory Management System of the CFX

code. CFX acts as the master process, remaining idle and waiting for results from RELAP to continue the coupled simulation. RELAP is called at every synchronization point using the RESTART option. A visual basic routine is developed in order to avoid excessive and inefficient growth of the RELAP restart file.

A description of the FORTRAN routine developed for the CFX part is given in Section 3.2.1, the PERL code and the data management within RELAP is described in Section 3.2.2. Finally the visual basic routine to manage the restart file is described in Section 3.2.3.

3.2.1 CFX

In order to be able to transfer data between codes, access to the internal data structures of the CFX solver is needed. Junction box routines in user FORTRAN allow internal data manipulation through the use of the CFX Memory Management System (MMS) utilities. These utilities are implemented in the code and described in the ANSYS manuals [51].

In the present work, data handling and transfer are managed mainly by three user FORTRAN subroutines shown in Figure 3 where a more detailed schematic sketch of the CFX part of the coupling tool is presented. The three user FORTRAN subroutines and their role in the coupling strategy are highlighted in the picture and described below.

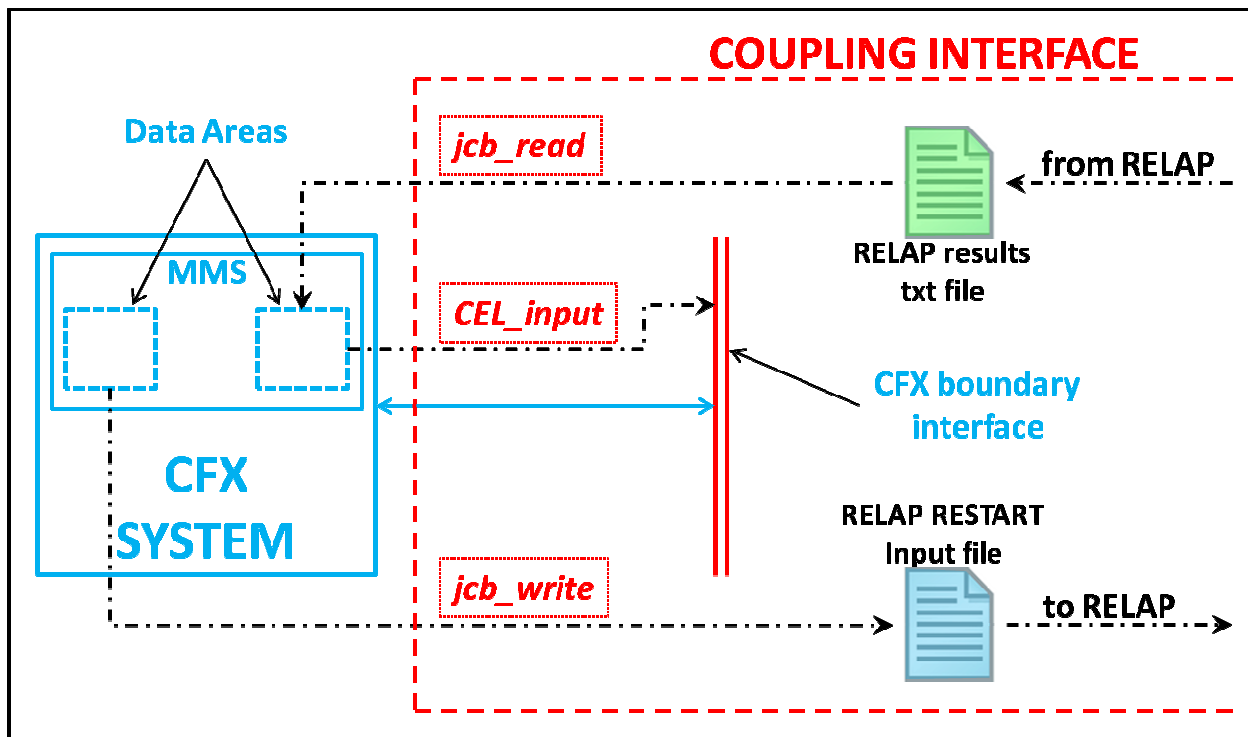

Figure 3: CFX Coupling Routines

- ***jcb_read***: junction box routine, called at the start of every coupled CFX step. It makes CFX solver wait for the RELAP result file of the previous coupled step (explicit coupling), then it takes single values of transferred variables from the result file and writes them in dedicated data areas of the MMS.
- ***jcb_write***: junction box routine, called at the end of every coupled CFX step. It computes suitable averages of the variables to be exchanged from the MMS data areas and writes them along with the time step size in the RELAP RESTART input file. It is important to note how the transferred data is calculated from the solution of the current time step, making the coupling sequential explicit (see Section 2.1.6). If needed the routine can also make conversions in order to transfer consistent values of the exchanged data (i.e. conversion from velocity to mass flow rates or conversion from relative to absolute pressure values). Under relaxation of some of the transferred values is also possible in order to



improve stability. Under relaxation works by limiting the amount which a variable changes from one coupled step to the next.

- **CEL_input:** user CEL routine. Takes values stored in the dedicated data areas by the jcb_read subroutine and use them to compute suitable boundary conditions (i.e. fully developed profiles can be constructed from mass flow rates and geometric data) and consistent transferred values (as described for the jcb_write junction box subroutine). Also in this case under-relaxation of some of the transferred values is possible.

3.2.2 External coupling routine

A PERL routine has been develop by GRNSPG-UNUPI to synchronize the two selected codes.

This routine launch RELAP when CFX provide an input file to initiate a new calculation or to restart sequentially the calculation after every coupling step. When the RELAP5 calculation finishes a strip procedure extract the information needed by CFX to continue the coupled calculation. Such values are then written into text files to be read by the CFX subroutines as described in the previous paragraph. During the CFX calculation the scrip launches CSES (described in the next paragraph) to manage the RELAP5 restart and prepare the auxiliary file needed by CSES to operate. The routine allows terminating a calculation after a prefixed simulation time. A flow diagram of the coupling routine is shown in Figure 4.

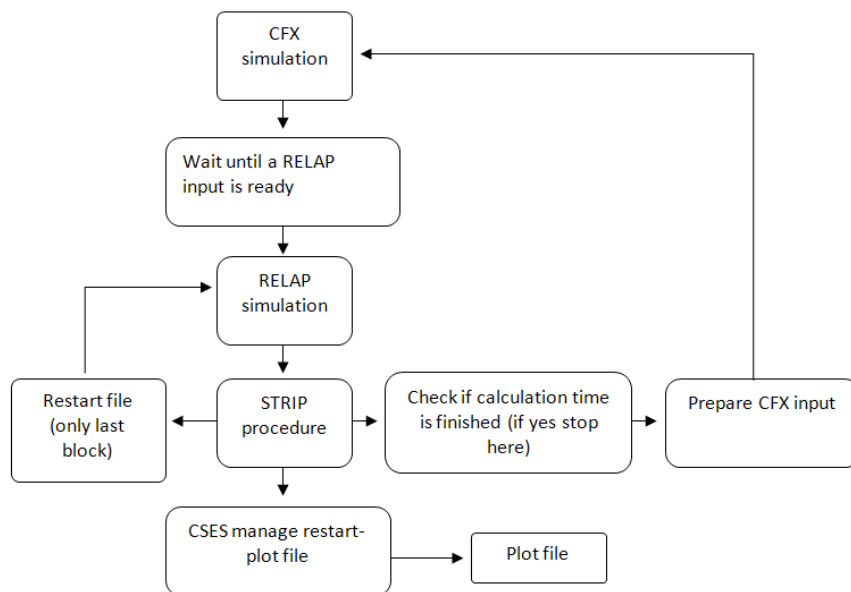

Figure 4: Flow Diagram of the Coupling Routine

3.2.3 CSES

CSES is a tool developed by GRNSPG-UNIPI to keep the dimension of the restart file under a certain value and to save useful information for graphical representation in a dedicated file with a user-selected frequency. This avoids huge restart-plot file if the coupling frequency is high.

Every coupling step RELAP5 produces a restart point in the restart-plot file. CSES open this file and search for the last plot block, copying it in a dedicated file. After that it delete a one of the previous restart block and keep at list the last one to restart RELAP5 calculation. It is also possible to save some intermediate restart blocks to start the calculation from selected intermediate instants. To operate CSES needs, as external input, the current time of calculation and a table that contains information about plot frequency and the intermediate restart point to save.



4 Test Case

Preliminary studies, involving stand-alone simulation with coupled boundary routines and homogeneous coupling (RELAP / RELAP and CFX / CFX), were conducted in order to test the coupling routines and to find possible programming issues. After that, a simple CFD/TH coupled test is performed in order to assess the capabilities and possible problems of the developed coupling tool. For simplicity, incompressible water at ambient condition is chosen as the working fluid, instead of liquid metal (molten lead). Thermo-physical properties of molten lead are already implemented in RELAP5-3D and can easily be implemented in CFX in a user defined material. Stand-alone calculations with molten lead have been performed and a coupled simulation can be set straightforward. In order to test coupling issues independently from possible problems arising from the use of liquid metals and considering that the implementation of such materials adds only a little value to the analysis of the coupling tool, results with incompressible water are presented. Simulations with molten lead are planned in future works.

In the following paragraphs a description of the coupled test and its results is presented.

4.1 Pressure drop test: RELAP-pipe / CFX-pipe

The coupled simulation studies the transient velocity rise inside a 5.3 m long pipe with internal diameter of 0.1 m and subject to a pressure difference between inlet and outlet of around 0.3 bar. The first five meters are modelled with RELAP while the last 0.3 with CFX. A pressure of 1.3 bar is defined in the RELAP time dependent volume modelling inlet conditions, while a pressure outlet is defined in CFX with relative pressure of 0 Pa, meaning an absolute value of 1 atm. The coupling interface is located 5 meters from the inlet. Variables chosen for the data exchange are velocity and pressure. In particular, velocity values are transferred from the RELAP outlet junction to the CFX inlet, while pressure values are transferred back from CFX inlet to the RELAP outlet time dependent volume. A uniform velocity is used at the CFX inlet, not taking into account a fully developed profile. For simplicity incompressible water at ambient condition is chosen as the working fluid.

4.1.1 Set up of the CFD model

A transient simulation with fixed time step of 0.01 s and total time of 10 s is set up. The following field equations are solved:

- Mass balance (Continuity)
- Momentum balance (Reynolds-averaged)
- Transport of turbulent kinetic energy (κ)
- Transport of turbulent eddy frequency (ω)

The turbulence is accounted for with the k - ω based Shear Stress Transport (SST) model ([51] and [52]). Based on UNIFI experience and common best practices in CFD analysis ([51] and [53]), a convergence criterion based on the following two conditions is applied:

- Maximum or if not possible Root Mean Square (RMS) normalized values of the equation residuals must drop by at least 4 orders of magnitude.
- Flow fields (velocity, pressure, etc.) must be stabilized.

Figure 5 shows the ICEM mesh for the CFX model. For simplicity a short length of the pipe (only 0.3 m) is modelled in order to keep a low number of grid nodes (~ 22 000) reducing computational times. The overall quality of the mesh is good (above 0.7) and the distance of the first node from the wall is 1 mm.

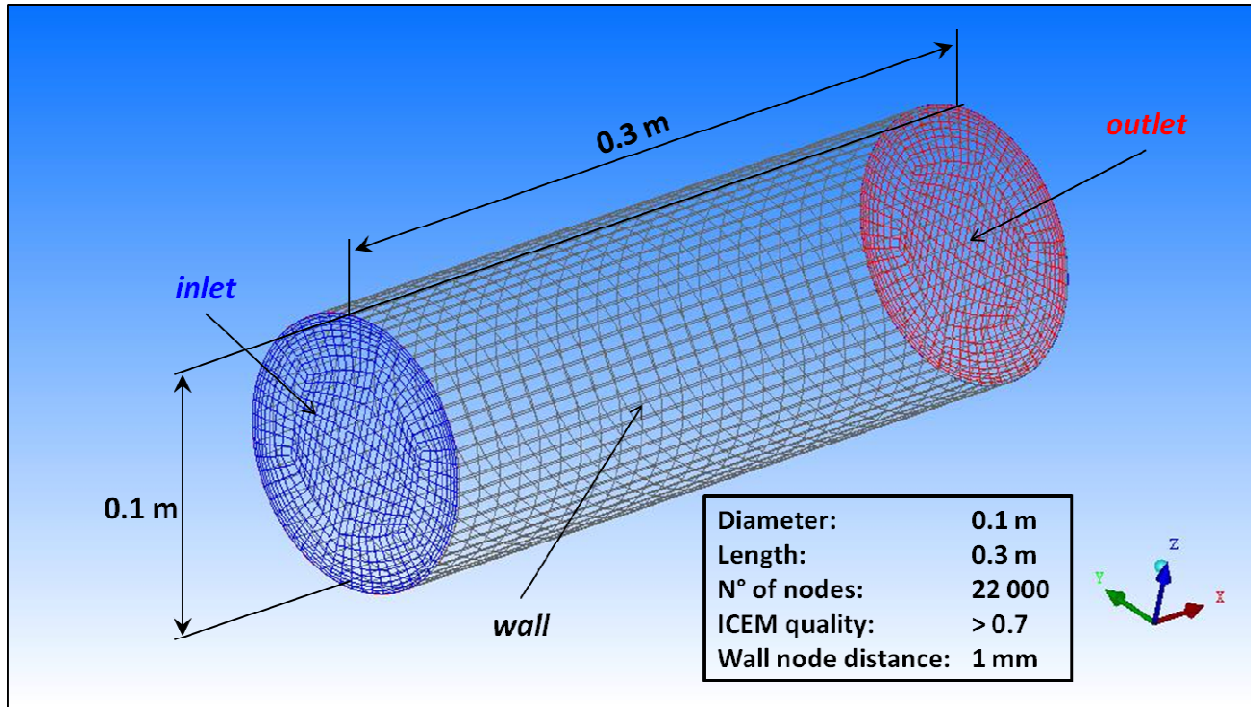

Figure 5: ICEM Model of the CFX Pipe

The following boundary conditions have been imposed (see Figure 5):

- *Inlet*: uniform velocity imposed through a function linked to the CEL_inlet subroutine
- *Outlet*: outlet pressure-controlled condition with zero relative pressure (absolute pressure equal to the reference pressure of 1 atm)
- *Wall*: No slip condition with automatic turbulence wall treatment and no wall roughness

Average pressure and velocity at the inlet are monitored in order to control convergence and coupling issues.

The simulation is run in serial mode (single processor).

4.1.2 Set up of the RELAP model

The RELAP model consists in a PIPE connected to two TIME DEPENDENT VOLUMES through two SINGLE JUNCTIONS.

PIPE 104 is 5 m long and with a diameter of 0.1 m. It's divided in 10 equal elements. Absolute roughness is set to zero and no additional concentrated loss factors or abrupt area change is modelled.

TIME DEPENDENT VOLUME 100 fixes the pressure at 1.1 bar while component 108 is used to realize the coupling. Namely the pressure in such component is imposed via a CONTROL VARIABLE updated by CFX within the input of every restart.

All velocities are initialized at zero.

A strip procedure extracts from the restart-plot file the value of the velocity in the SINGLE JUNCTION 106 that models the connection with CFX domain.

The maximum time step for the transient simulation is set to 0.001 seconds, the coupling step being 0.01 s.

Figure 6 shows the nodalization of the RELAP model.

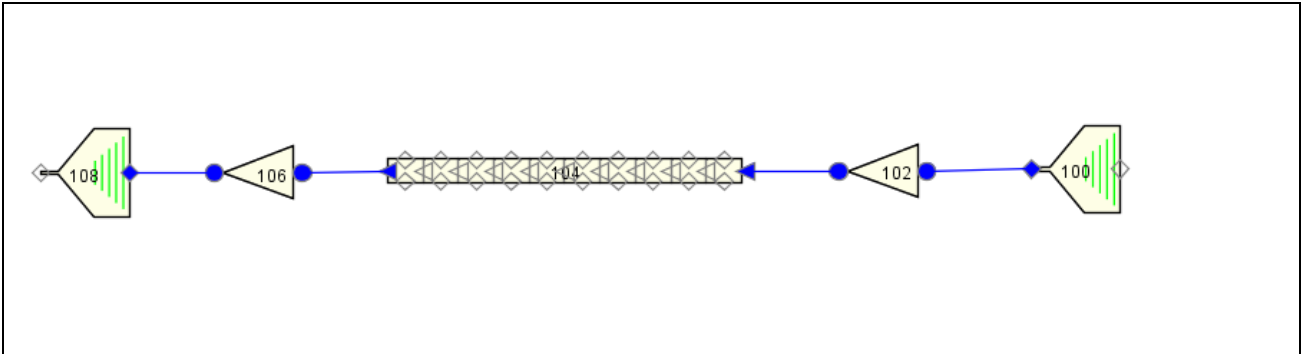

Figure 6: Nodalization of the Pipe Modelled with RELAP

4.1.3 Results

The overall computational time of the coupled simulation is about 40 minutes, a stand-alone CFX simulation using the same grid (only 0.3 m of pipe) with comparable settings have a computational time of about 36 minutes. The difference of 4 minutes (~ 10% of the computational time) is mainly for I/O activities and user-subroutines. Such small difference justify the use of I/O routines over direct memory transfer, especially taking into account the relative small grid used in the present coupling simulation. A full CFX simulation of the whole pipe (5.3 meters) with total number of grid nodes of ~ 72 000 has a computational time of about 1 hour and 56 minutes.

In Figure 7 MAX residuals for the CFD simulation are shown. All residuals fall under 10^{-4} mainly within 3-4 inner iterations (in the first part of the simulation more inner iterations are required).

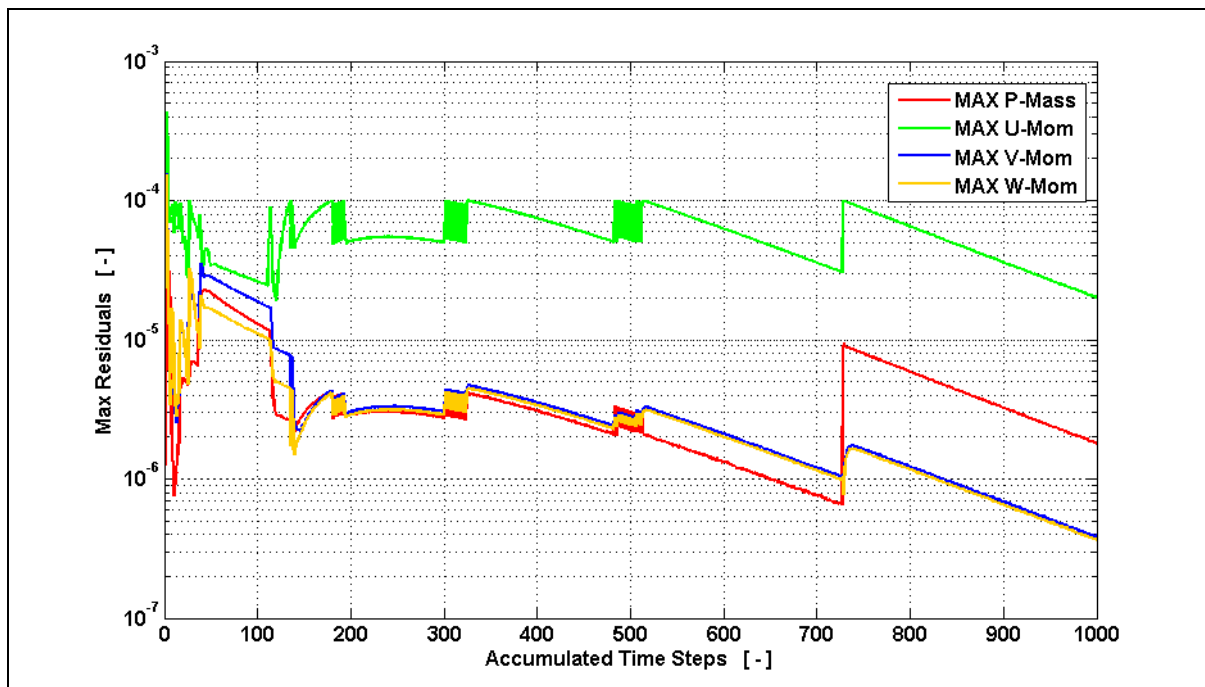

Figure 7: Max Residuals

Maximum values of normalized wall distance y^+ are under 300, coherently with the automatic wall treatment of the SST turbulence model.

The velocity rise in the pipe is shown in Figure 8. Coupled results are compared with a RELAP stand-alone simulation. It is interesting to note that maximum relative errors are less than 1%.

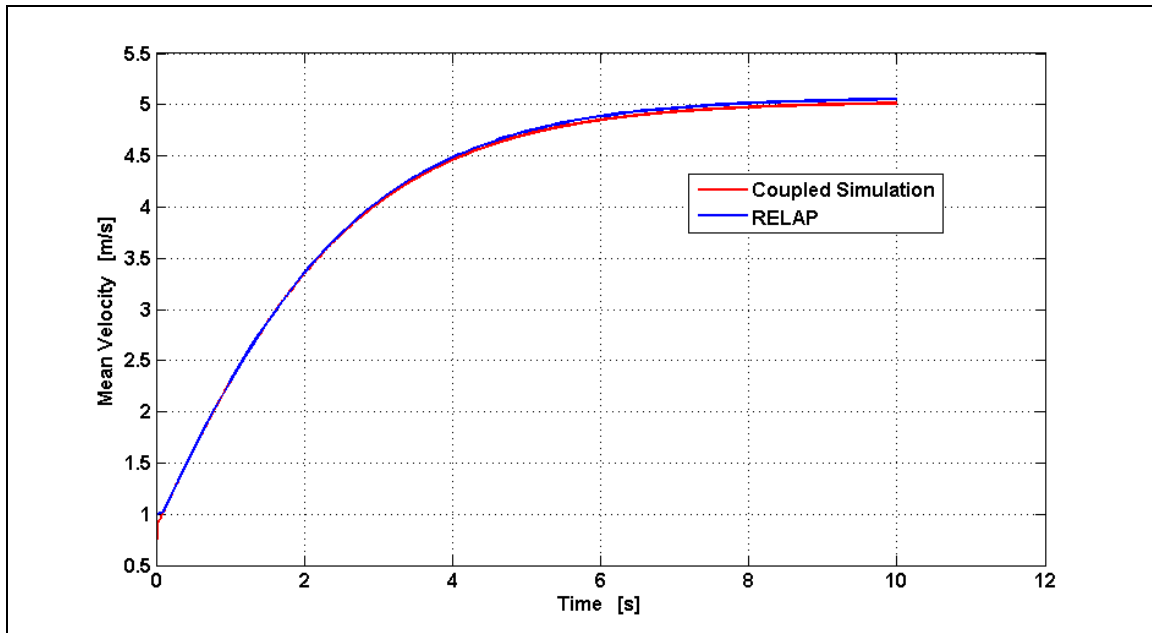

Figure 8: Velocity Rise

The relative pressure evolution at the interface is shown in Figure 9. The high oscillations present in the very first part of the simulation are due to instabilities coming from the unsteady term in the momentum balance. In particular, velocity adjustments after initialization introduce relatively high inertial components that in turn create pressure oscillations. Such phenomena are stronger if the fluid material is perfectly incompressible (as in the CFX model) and grows with the size of the liquid inventory in the CFX part. Depending on the size of the CFX domain, this can bring to growing oscillations that compromise the solution of the coupled simulation. Under relaxation can be used to bypass this problem.

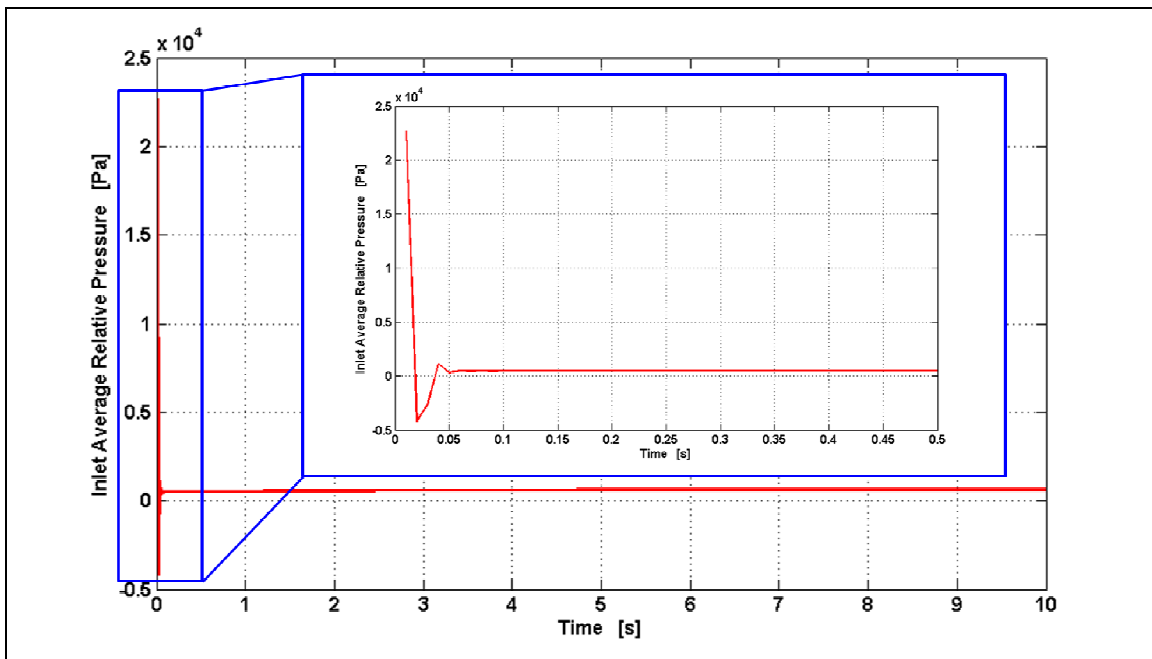

Figure 9: Pressure Evolution



For the regime solution (at $t = 10s$), the pressure drop along the pipe is plotted in Figure 10. It is interesting to note how the last part of the pipe, modelled in CFX, has a different slope with respect to the RELAP part. This is due to the imposed uniform velocity profile; a fully developed profile will have returned a slope coherent with the friction models used in RELAP.

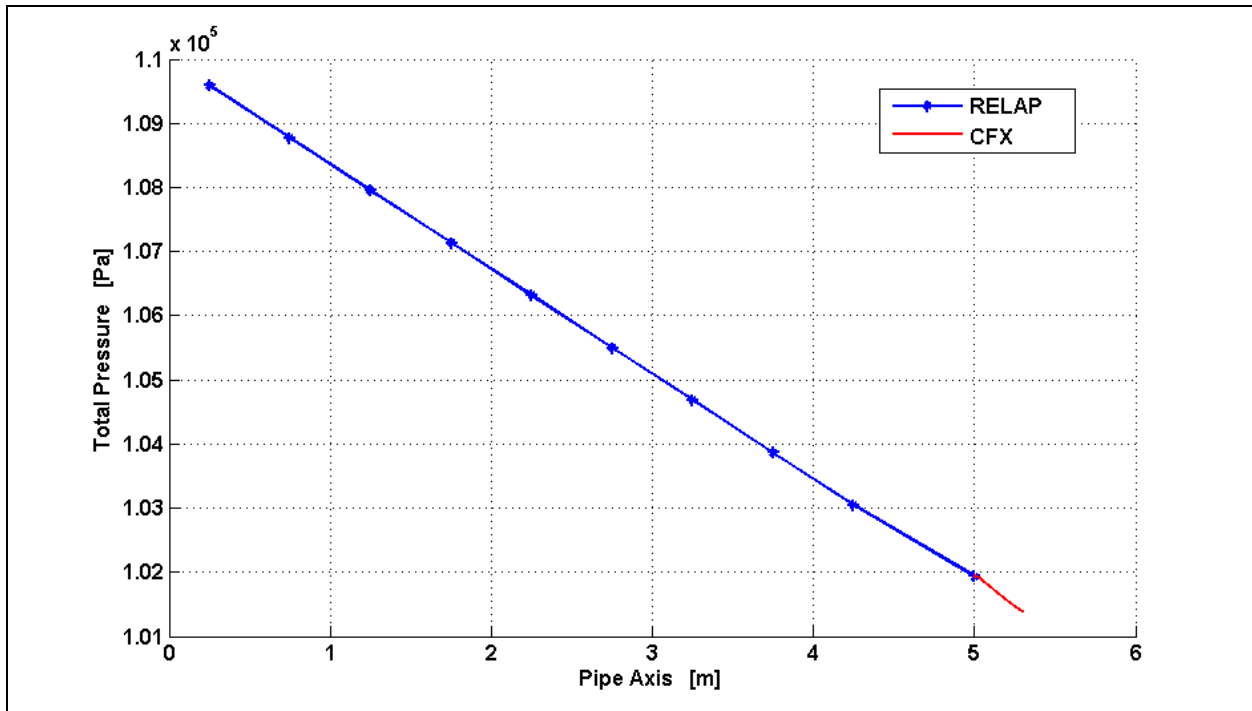

Figure 10: Pressure Along the Pipe Axis

5 Conclusions and future development

A literature review of the coupling between system codes and CFD codes is presented. Several papers and works about 1D / 3D coupling are found from both within and outside the nuclear community. In most of the works a partitioned approach is preferred where independent dedicated solvers can be used for each sub-domain while an external interface software handles the data transfer between codes. In such approach, the access to the code sources is not essential, which makes it more versatile and inherently modular.

Several coupling issues are addressed and analyzed in some detail in the works found in literature, mainly: non-uniformities between coupled sub-domains, data inconsistency (1D – 3D) and coupling schemes. On the other hand, a detailed description of the coupling algorithm and numerical schemes is seldom provided and, to the Authors' knowledge, a great part of the relevant information is proprietary and usually not shared in the literature.

In some works a coupling tool is tested against simple examples or experimental data, in some other cases comparisons with real plant scenarios are presented. Unfortunately, even if suggested, a complete and systematic assessment is not available in the examined literature.

In order to develop an effective and reliable coupling tool, different identified issues have to be investigated independently and then a validation against more complicated phenomena and real plant scenarios should be pursued.

A preliminary study for the development of a coupling tool has been a further objective of the present work and is presented in the report. Since a very simple demonstration case is requested, a simple sequential, explicit coupling is chosen where interface data is written in text files and transferred through Input / Output (I/O) external routines. The coupling is between RELAP codes and ANSYS CFX code. For simplicity, incompressible water at ambient condition is chosen as the working fluid, instead of liquid metal (molten lead)¹. In order to test coupling issues independently from possible problems arising from the use of liquid metals, results with incompressible water are presented leaving for future works calculation with liquid metals. A simple pipe flow test is studied with the coupled tool. Coupled results shows good comparison with respect to RELAP stand alone simulations. Some stability issues are found, probably due to the explicitness of the coupling scheme.

Further efforts are required before a full-featured and robust coupling tool can be achieved. The following tasks are recommended for future development:

- Development of more robust coupling schemes
- Extension to parallel computing capabilities
- Independent assessment and verification of each identified issue
- Development of a more compact and integrated tool, with the possible addition of a user-friendly graphical interface
- Definition of systematic coupled-code validation campaign.

A dedicated mid-term research program involving both nuclear thermal hydraulics and information technology resources could reasonably achieve the target.

¹ Thermo-physical properties of molten lead are already implemented in RELAP5-3D and can easily be implemented in CFX as a user defined material. Stand-alone calculations with molten lead have been performed and the set-up of a liquid-metal coupled simulation would be straightforward and, on the other hand, would have not brought any added value to the present study.



References

- [1] Zienkiewicz O.C.: *Coupled problems and their numerical solution*. In Lewis R. W., Bettes P., Hinton E. (eds): *Numerical Methods in Coupled Systems*, John Wiley & Sons, (1984).
- [2] Hackbusch W., Wittum G. (eds.): *Numerical Treatment of Coupled Problems*, Vol. 51 of Notes on Numerical Fluid Mechanics, Vieweg, (1995).
- [3] Weinan E., Engquist B., Huang Z.: *Heterogeneous multiscale method: A general methodology for multiscale modeling*, (2003)
- [4] Weinan E., Engquist B., Li X., Ren W., Vanden-Eijnden E.: *The Heterogeneous Multiscale Methods: a Review*, *Commun. Comput. Phys.*, 2, 67-450, (2007).
- [5] Hermann G. Matthies, Jan Steindorf: *Strong Coupling Methods*, (2002).
- [6] Miguel A. Fernandez: *Coupling schemes for incompressible fluid structure interaction: implicit, semi-implicit and explicit*, (2011).
- [7] MpCCI 4.1.1-2 Manuals, (2011).
- [8] Lee S. Y., J.-J., Kim, S.H., and Chang, S.H.: *COBRA/RELAP5: A merged version of the COBRA-TF and RELAP5/MOD3 codes*, *Nucl. Tech.*, 99, 177, (1992).
- [9] J. J. Jeong, S. K. Kim, C. H. Ban, C. E. Park, *Assessment of the COBRA/RELAP5 Code Using The LOFT L2-3 Large-Break Loss-Of-Coolant Experiment*, *Ann. Nucl. Energy*, 24, 14, 1171-1182, (1997).
- [10] J.-J. Jeong, K.S. Ha, B.D. Chung, W.J. Lee: *Development of a multi-dimensional thermal-hydraulic system code, MARS 1.3.1*, *Annals of Nuclear Energy* 26, 1611-1642, (1999).
- [11] Prassinis, P. G. et al., NUREG/CR-0792, USNRC, (1979).
- [12] Bayless, P.D., Divine, J.M., NUREG/CR-2826, EGG-2210, U.S. USNRC (1982).
- [13] Paik, C.Y. et al., EPRI NP-4111, Electric Power Research Institute, (1986).
- [14] U. Graf: *Implicit Coupling of Fluid-Dynamic Systems: Application to Multidimensional Countercurrent Two-Phase Flow of Water and Steam*, *Nucl. Sci. Eng.*, 129, 305-310, (1998).
- [15] P. Weiss, M. Sawitzki, F. Winker: *UPTF, a Full Scale PWR Loss-of-Coolant Accident Experiment Program*, *Kerntechnik*, 49, (1986).
- [16] S. Kliem, T. Höhne, U. Rohde, and F.-P. Weiss: *Main Steam Line Break Analysis of a VVER-440 Reactor Using the Coupled Thermohydraulics System/3D-Neutron Kinetics Code DYN3D/ATHLET in Combination with the CFD Code CFX-4*, *Proc. 9th Int. Topl. Mtg. Nuclear Reactor Thermal Hydraulics (NURETH-9)*, San Francisco, California, October 3-8, (1999).
- [17] Dräger, P.: *Makroskopische Kühlmittelvermischung in Druckwasserreaktoren*. Dissertation A, TH Zittau, (1987).
- [18] D. L. Aumiller, E. T. Tomlinson, R. C. Bauer, *A Coupled RELAP5-3D/CFD Methodology With a Proof-Of-Principle Calculation*, *Nucl. Eng. Des.*, 205, 83-90, (2001).
- [19] Edwards A. R., O'Brien T.P.: *Studies of phenomena connected with the depressurization of water reactors*. *J. of the British Nucl. Energy Soc.* 9, 125-135, (1970).
- [20] Weaver, W.L., Tomlinson, E.T., Aumiller, D.L.: *A Generic Semi-Implicit Coupling Methodology For Use In RELAP5-3D©*, *Nuclear Engineering and Design* 211, 13-26, (2002).

- [21] D. L. Aumiller, E.T. Tomlinson, W. L. Weaver: *An Integrated RELAP5-3D and Multiphase CFD Code System Utilizing a Semi-Implicit Coupling Technique*, Nucl. Eng. Des., 216, 77-87, (2002).
- [22] Christensen H.: *Power-to-void transfer functions*, ANL-6385, AEC Research and Development Report, (1961).
- [23] W.L. Weaver: *A Mass and Energy Conserving Form of Explicit Coupling For Use With RELAP5-3D@*, 2002 RELAP5 International Users Seminar, (2002).
- [24] W. L. Weaver: *The Application Programming Interface For The PVMEXEC Program And Associated Code Coupling System*, (2005).
- [25] Richard R. Schultz, Walter L. Weaver, Abderrafi M. Ougouag: *Validating & Verifying A New Thermal-Hydraulic Analysis Tool*, Proceedings of ICONE10, 10th International Conference on Nuclear Engineering, (2002).
- [26] Richard R. Schultz, Walter L. Weaver: *Coupling The RELAP5-3D Advanced System Analysis Code With Commercial And Advanced CFD Software*, Proceedings of IAEA Technical Meeting, Use of CFD Codes for Safety Analysis of Reactor Systems, (2002).
- [27] Richard R. Schultz, Walter L. Weaver, Richard W. Johnson, David G. Schowalter, Nalanjana Basu: *Evaluating Fluid Behaviour In Advanced Reactor Systems Using Coupled Computational Fluid Dynamics And Systems Analysis Tools*, Proceedings of ICONE13, 13th International Conference on Nuclear Engineering, (2005).
- [28] Nolan Alan Anderson: *Coupling RELAP5-3D@ and Fluent to Analyze a Very High Temperature Reactor (CHTR) Outlet Plenum*, (2006).
- [29] H. Gibeling, J. Mahaffy: *Benchmarking Simulations with CFD to 1-D Coupling*, Joint IAEA/OECD Technical Meeting on Use of CFD Codes for Safety Analysis of Reactor Systems, Including Containment, Pisa, Italy, (2002).
- [30] Laufer J.: *The structure of turbulence in fully developed pipe flow*, NACA Report, NACA-TN-2954 (1953).
- [31] Annalisa Ambroso: *Coupling of Multiphase Flow Models*, The 11th International Topical Meeting on Nuclear Thermal-Hydraulics (NURETH-11), (2005).
- [32] Cadinu F., Kozlowski T., Dinh T.-N.: *Relating system-to-CFD coupled code analyses to theoretical framework of a multiscale method*, Proc. ICAPP 2007, Nice, France, May 13-18, 2007. Paper 7539, (2007).
- [33] IAEA document: *Use and Development of Coupled Computer Codes for the Analysis of Accidents at Nuclear Power Plants*, Proceedings of a technical meeting held in Vienna, 26–28 November 2003. (2007).
- [34] Yizhou Yan, Rizwan-uddin, Kyungdoo Kim: *A Coupled CFD-System Code Development and Application*, International Conference on the Physics of Reactors “Nuclear Power: A Sustainable Resource”, (2008).
- [35] Yizhou Yan, Rizwan-uddin: *Coupled CFD—System-Code Simulation of a Gas Cooled Reactor*, International Conference on Mathematics and Computational Methods Applied to Nuclear Science and Engineering (M&C 2011), (2011).
- [36] D. Bertolotto, A. Manera, and et al.: *Single-phase mixing studies by means of a directly coupled CFD/system-code tool*, Proceeding of Physor 08 Meeting, Interlaken, Switzerland, September 14-19, (2008).
- [37] D. Bertolotto: *Coupling a System Code with Computational Fluid Dynamics for the Simulation of Complex Coolant Reactivity Effects*, Doctoral thesis, (2011).



- [38] C. L. Waata, T. Frank: *Development of CFD software for the simulation of multidimensional Flows in the nuclear reactor cooling system - coupling of ANSYS CFX with 1D system code ATHLET*, Tech. Rep. ANSYS TR-08-02, ANSYS Germany, Mar. (2008).
- [39] A. Papukchiev, G. Lerchl, C. Waata, T. Frank: *Extension of the simulation capabilities of the 1D system code ATHLET by coupling with the 3D CFD software package ANSYS CFX*, in Proceedings NURETH-13, Sept. (2009).
- [40] A. Papukchiev, G. Lerchl: *Development of an Interface with Different Schemes for the Coupling of the 1D System Code ATHLET with the 3d CFD Software Package ANSYS CFX*, (2010).
- [41] A. Papukchiev, G. Lerchl: *Assessment of the Performance of the 1D-3D Code System ATHLET – ANSYS CFX with Explicit and Semi-implicit Coupling Schemes*, (2011).
- [42] A. Papukchiev, G. Lerchl, M. Scheuerer: *Coupled ATHLET – ANSYS CFX Calculations of the OECD/NEA Large Scale Test Facility ROSA V Test 1-1*, (2011).
- [43] Ladislav Vyskocil: *Simulation of MSLB Case at VVER-1000 Primary Circuit by Coupled CATHARE and TRIO-U Codes*, (2011).
- [44] Meca R., Macek J., Hádek J.: *Metodika pro provádění Best-Estimate bezpečnostních analýz z bezpečnostního hodnocení kampaní události roztržení parního kolektoru PG pro JE VVER-1000/320 Temelín*, ÚJV Z1559T, Listopad (2005).
- [45] Zhiqian Zhai, Qingyan (Yan) Chen: *Solution Character of Iterative Coupling Between Energy Simulation and CFD Programs*, Energy and Building 35, 493-505, (2003).
- [46] Gino Bella, Rossella Rotondi, Gabriel Defranco y Norberto Nigro: *Code Coupling to Enhance CFD Analysis of I.C. Engines*, Mecánica Computacional Vol. XXII, (2003).
- [47] J. Galindo, A. Tiseira, P. Fajardo , R. Navarro: *Coupling methodology of 1D finite difference and 3D finite volume CFD codes based on the Method of Characteristics*, Mathematical and Computer Modelling 54 (2011) 1738–1746, (2011).
- [48] G. Sod: *A survey of several finite difference methods for systems of nonlinear hyperbolic conservation laws*, Journal of Computational Physics 27 (1) (1978) 1–31, (1978).
- [49] Klaus Wolf: *MpCCI – The General Code Coupling Interface*, (2007).
- [50] Pascal Bayrasy: *1D-3D Co-Simulation of an Aircraft Environment Control System*, (2010).
- [51] ANSYS CFX-14.0 User Manual, 2012 (embedded in the software package).
- [52] D. Wilcox, *Turbulence Modelling for CFD*, DCW Industries, Inc., Griffin printing, California, (2000).
- [53] F. Menter, *CFD Best Practice Guidelines for CFD Code Validation for Reactor-Safety Applications*, EU/FP5 ECORA Project “Evaluation of computational fluid dynamic methods for reactor safety analysis”, EVOL-ECORA-D01, Germany, February (2002).

Curriculum Scientifico del Gruppo di Lavoro

Francesco D'auria

Professore Ordinario di Termoidraulica e di Ingegneria del Nocciolo (Moduli dell'insegnamento Termoidraulica e Ingegneria del Nocciolo Cod. 424II) per il Corso di Laurea Magistrale in Ingegneria Nucleare - Università di Pisa.

Autore di oltre 100 articoli su rivista e numerose altre pubblicazioni (<http://arp.unipi.it/listedoc.php?ide=5808>).

Marco Lanfredini

Laureando in Ingegneria Nucleare, collaboratore dal 2011 presso il Gruppo di Ricerca Nucleare S. Piero a Grado - Università di Pisa quale utilizzatore di codici termoidraulici di sistema.

Autore di rapporti tecnici interni e di articoli scientifici facilmente reperibili sui principali motori di ricerca specializzati.

Lorenzo Mengali

Ingegnere Aerospaziale, collaboratore dal 2008 presso il Gruppo di Ricerca Nucleare S. Piero a Grado - Università di Pisa, quale esperto di Fluidodinamica Computazionale.

Autore di rapporti tecnici interni e di articoli scientifici facilmente reperibili sui principali motori di ricerca specializzati.

Fabio Moretti

Ingegnere Nucleare (2004), Dottore di Ricerca in Sicurezza Nucleare e Industriale (2009), collaboratore dal 2008 presso il Gruppo di Ricerca Nucleare S. Piero a Grado - Università di Pisa, quale coordinatore dell'area Fluidodinamica Computazionale e responsabile di attività sperimentali e di training.

Autore di rapporti tecnici interni e di articoli scientifici facilmente reperibili sui principali motori di ricerca specializzati.