



Agenzia nazionale per le nuove tecnologie,
l'energia e lo sviluppo economico sostenibile



RICERCA DI
SISTEMA ELETTRICO



MINISTERO DELLO SVILUPPO ECONOMICO

Accordo di Programma MiSE-ENEA

Sistema di ricarica contactless dinamica



Univ. Co-beneficiaria
Università di Padova, Dipartimento di Ingegneria Industriale

13/12/2018

ENEA-DTE-PCU-STMA

ENEA-SSPT-TECS-TEB



1101 0110 1100
0101 0010 1101
0001 0110 1110
1101 0010 1101
1111 1010 0000



Mobilità elettrica : idonea per la mobilità urbana

Superamento del limite in autonomia :
capacità accumulo – diffusione infrastrutture ricarica fast charge

Ricarica continua e/o alimentazione powertrain su
tracciati extra-urbani dedicati

Riduzione del peso a bordo

Ricerche in ambito Europeo : analisi di fattibilità e realizzazione
prototipi con il fine di aumentarne l'autonomia

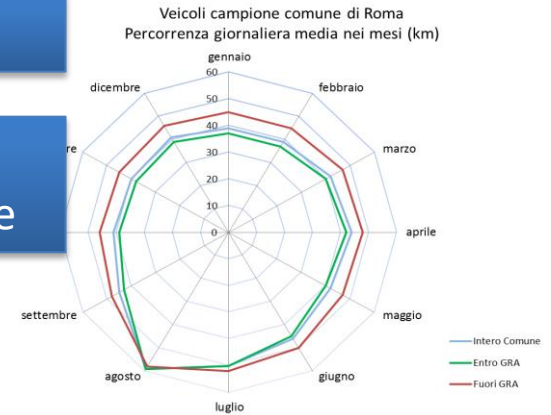

56% <30 km, 83 % <60 km, 94.4 % <100 km

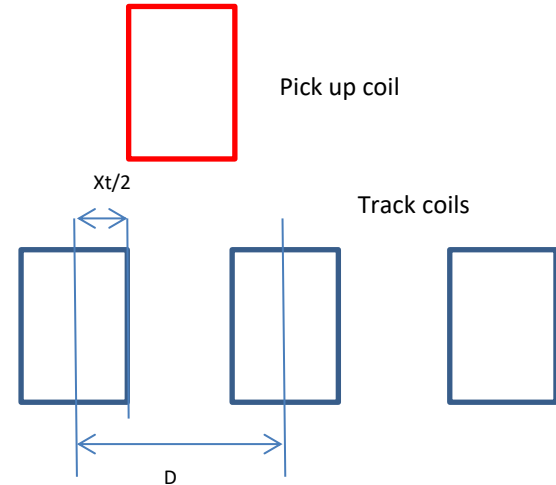
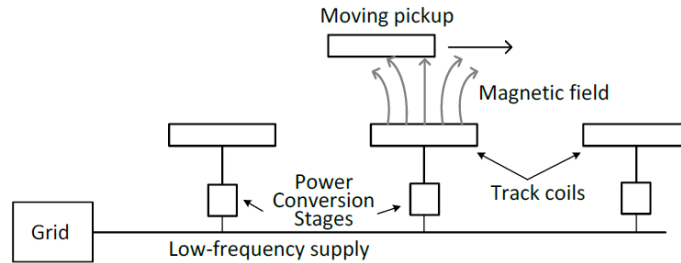

$$Xt/D=1$$

- Rende massima l'energia trasferita
- Riduce le escursioni di potenza dalla rete
- Semplifica il circuito del secondario

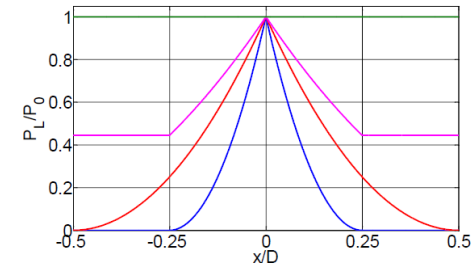

Potenza trasferita vs. x/D per $Xt/D=1$ (verde), $3/4$ (viola), $1/2$ (rosso), $1/4$ (blu).

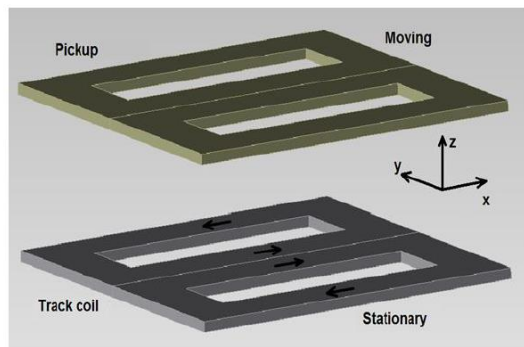

Bobine polarizzate tipo DD

Maggiore flusso concatenato tra Tx e Rx

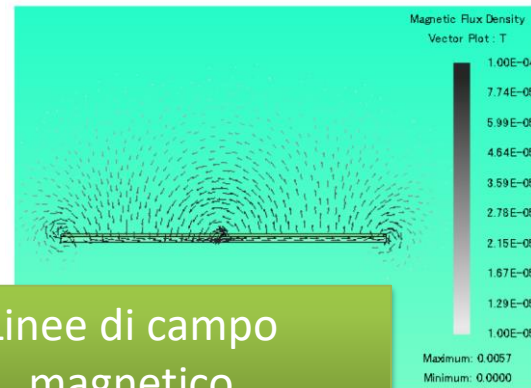

Linee di campo magnetico

Progettazione coil: 4 spire con ferrite

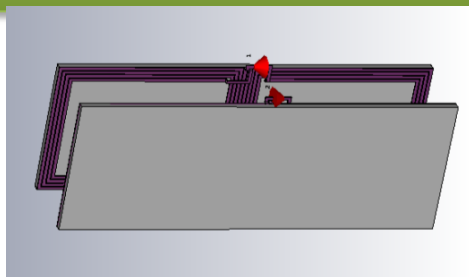

Ottimizzazione con ferriti a barre

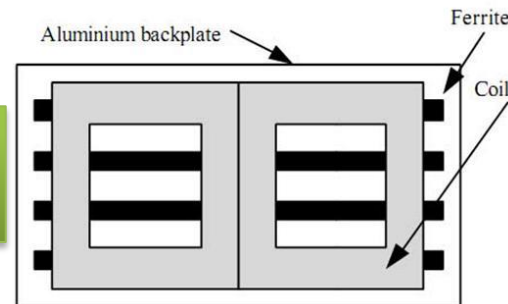

Circuito di compensazione
LCL sul track

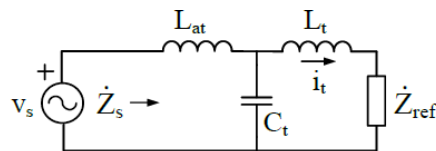

Corrente nella bobina di
track è indipendente dalla
posizione del pickup

$$\bar{I}_t = \frac{\bar{V}_s}{\dot{Z}_s} \frac{\frac{1}{j\omega_s C_t}}{\frac{1}{j\omega_s C_t} + j\omega_s L_t + \dot{Z}_{ref}} = \frac{\bar{V}_s}{j\omega_s L_t}$$

Non necessario
retroazione della corrente
di pickup



Veicolo Urb-e

Batterie 48 V 120 Ah
P ricarica 700 W
P moto 2.4 kW
P trasferita 3.1 kW

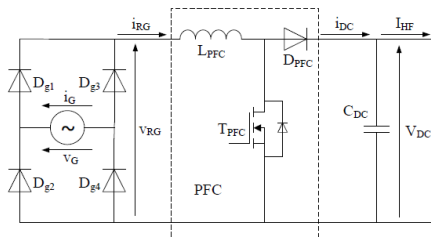

PFC per ridurre il power factor verso la rete

La somma M_1+M_2 se le bobine sono disposte affiancate è pari a M_0 mutua induttanza tra una bobina Tx e la Rx in condizioni di allineamento

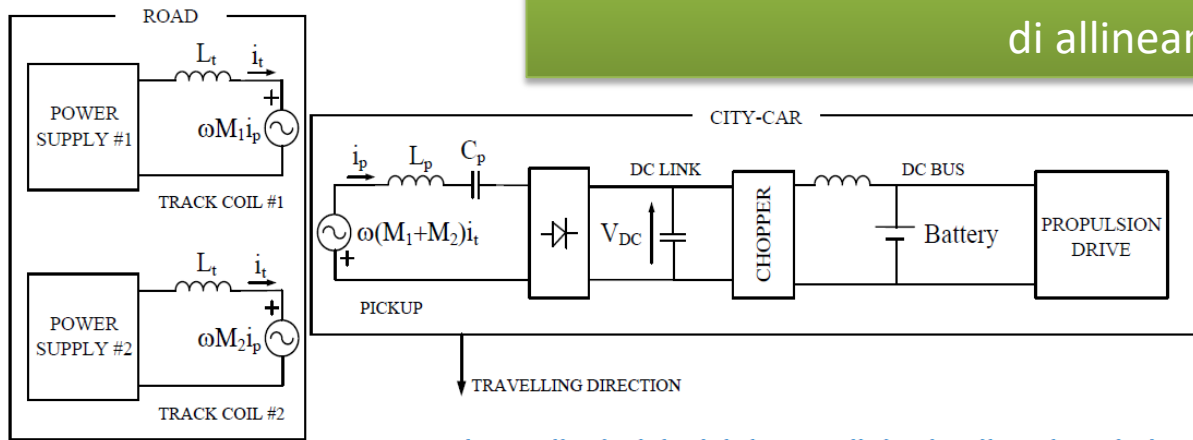

Se I_t è costante la potenza trasferita è costante in risonanza

Schema di principio del sistema di ricarica dinamica wireless.

f=81-89 kHz P=3.1 kW

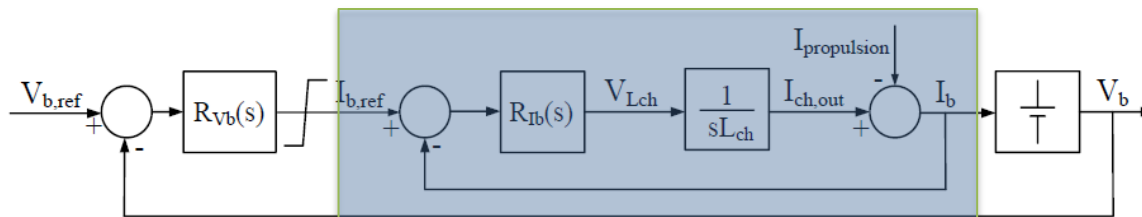

Anello di controllo sezione ricevente

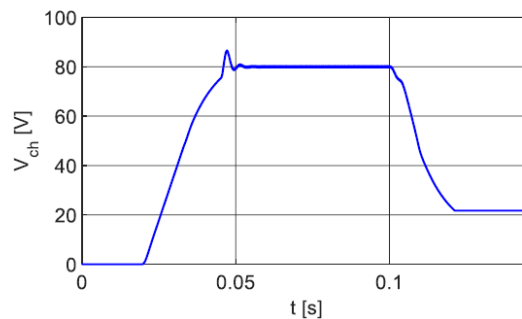

(a)

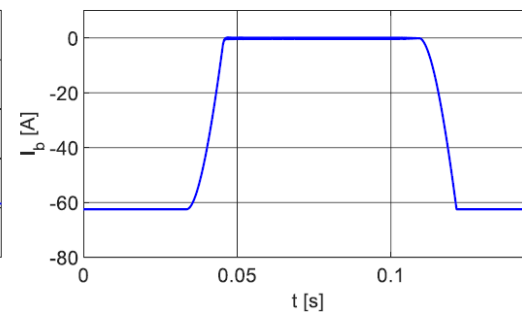

(b)

Figura 25. a) Tensione V_{ch} . b) Corrente I_b

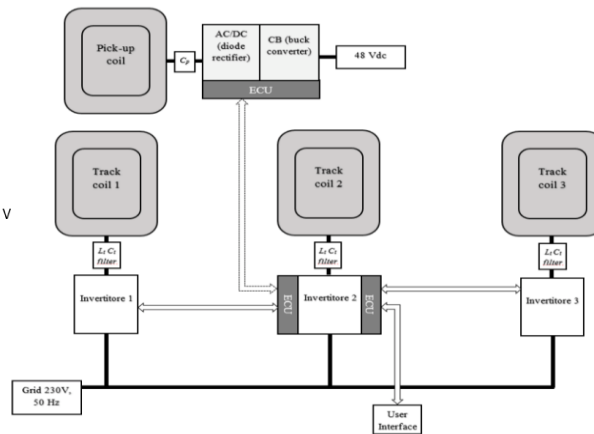
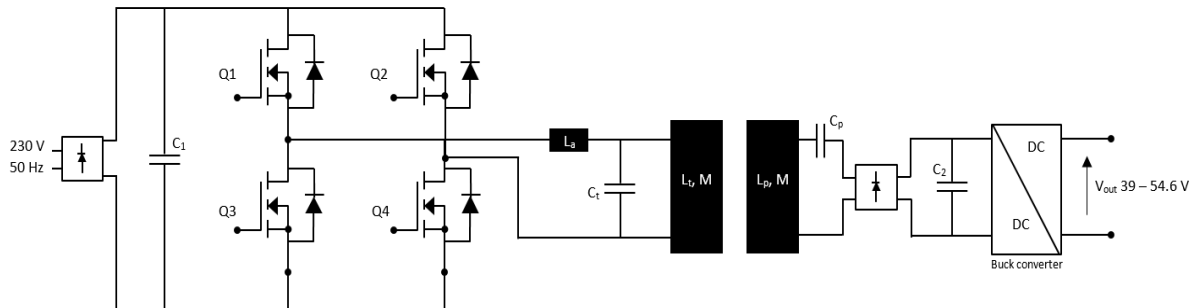

Denominazione	simbolo	Valore
Potenza nominale di uscita	Po	3 kW
Condensatore dc-link	C ₁	1.2 mF
Bobina ausiliaria	L _a	58 μH
Condensatore bob. trasm.	C _t	55.52 nF
Bobina trasmittente	L _t	58 μH
Bobina pick-up	L _p	58 μH
Condensatore bob. pick-up	C _p	55.52 nF
Mutua	M	16.5 μH
Condensatore filtro	C ₂	7.2 mF

$$F_{sw_R} = 88.691 \text{ kHz}$$

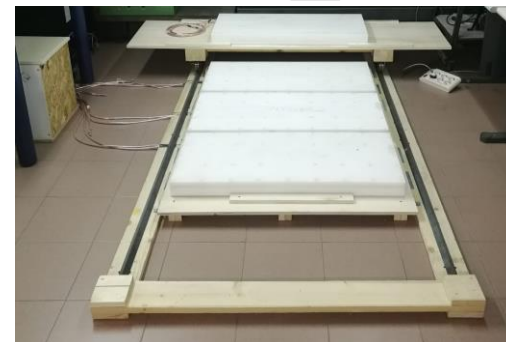

Prototipo

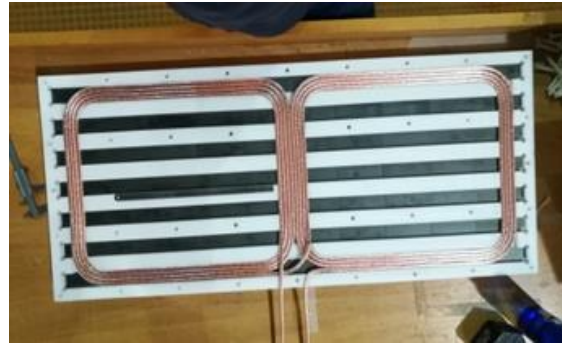
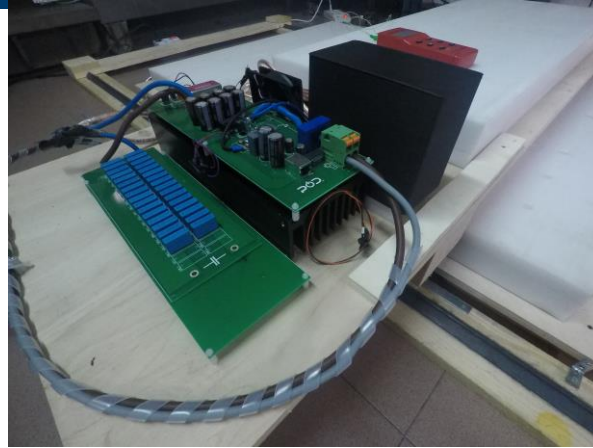

Test di scorrimento

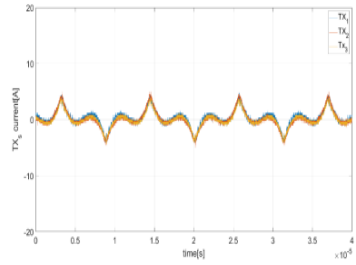
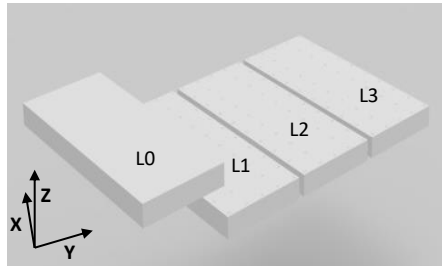

-87 cm

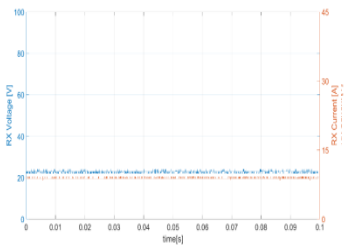
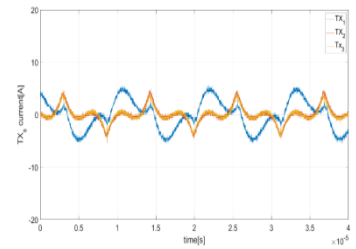
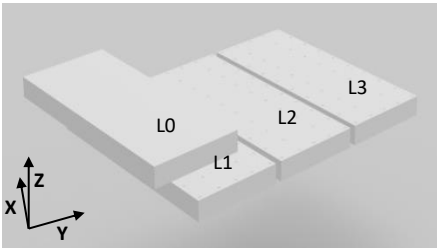

-64 cm

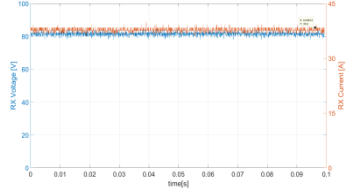
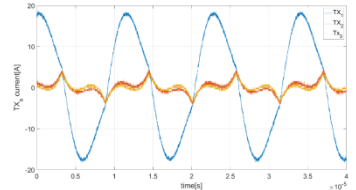
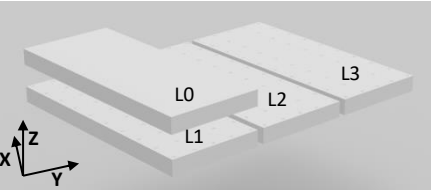

-45 cm

Test di scorrimento

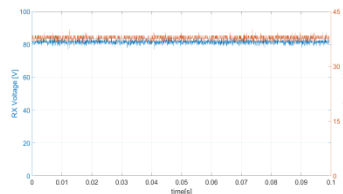
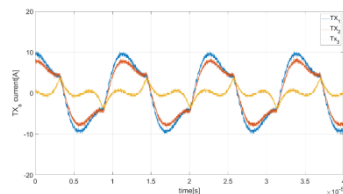
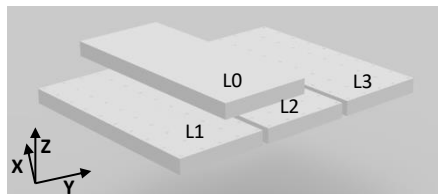

-22.5 cm

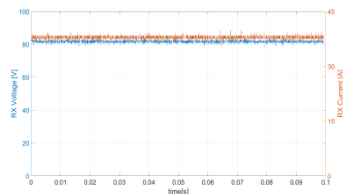
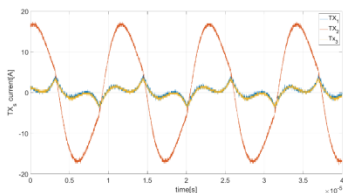
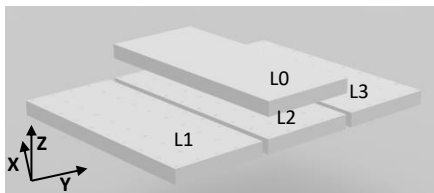

-0 cm

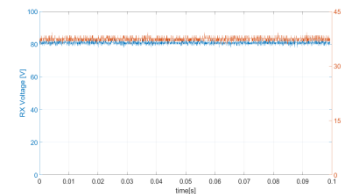
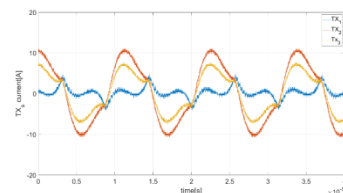
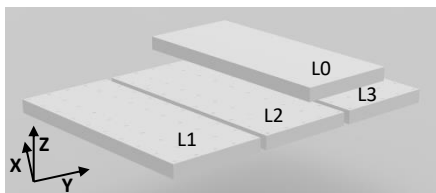

22.5 cm

3.3 ± 0.4 kW

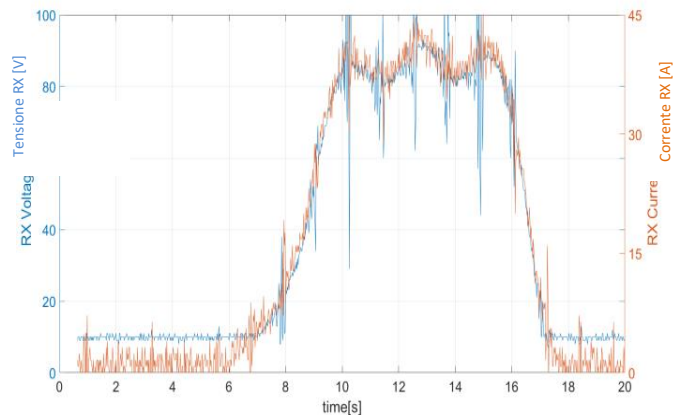

Tensione Rx Corrente Rx

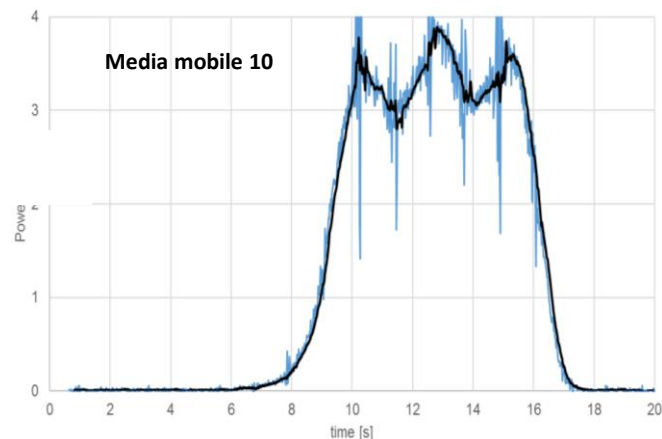

Potenza (kW)



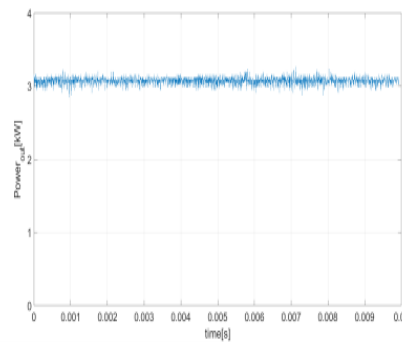
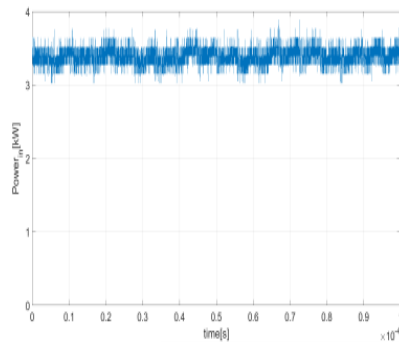
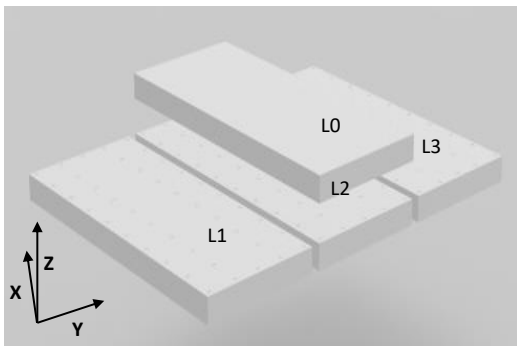

L2 Tx L0 Rx

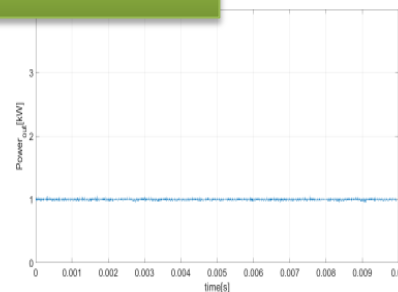
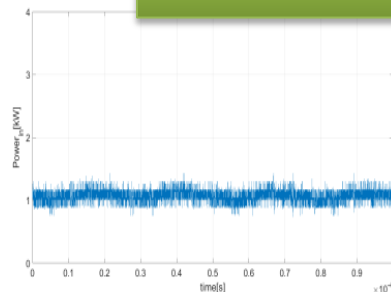
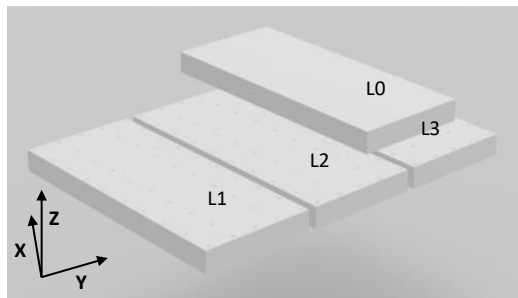

Efficienza 90.8%

Efficienza 93.3%



Agenzia nazionale per le nuove tecnologie,
l'energia e lo sviluppo economico sostenibile



RICERCA DI
SISTEMA ELETTRICO



MINISTERO DELLO SVILUPPO ECONOMICO

Accordo di Programma MiSE-ENEA

Sistema di ricarica high power/fast charge

Univ. Co-beneficiaria
Università di Cassino, Dipartimento di Ingegneria Elettrica e dell'Informazione



13/12/2018

ENEA-DTE-PCU-STMA



1101 0110 1100
0101 0010 1101
0001 0110 1110
1101 0010 1101
1111 1010 0000



High power/fast charge per veicoli elettrici



Convertitore “multi-port” per stazioni di ricarica di veicoli elettrici **standard e ultra-fast**.

Disaccoppiare in potenza la stazione o le stazioni di ricarica dei veicoli dalla rete elettrica mediante uno stadio intermedio in cui sono installati dei sistemi di accumulo energetico

Soluzione di tipo modulare, può essere composta o estesa in funzione della disponibilità di potenza in ingresso, dei livelli di tensione della rete elettrica a cui ci si è collegati e della tipologia di ricarica da effettuare.

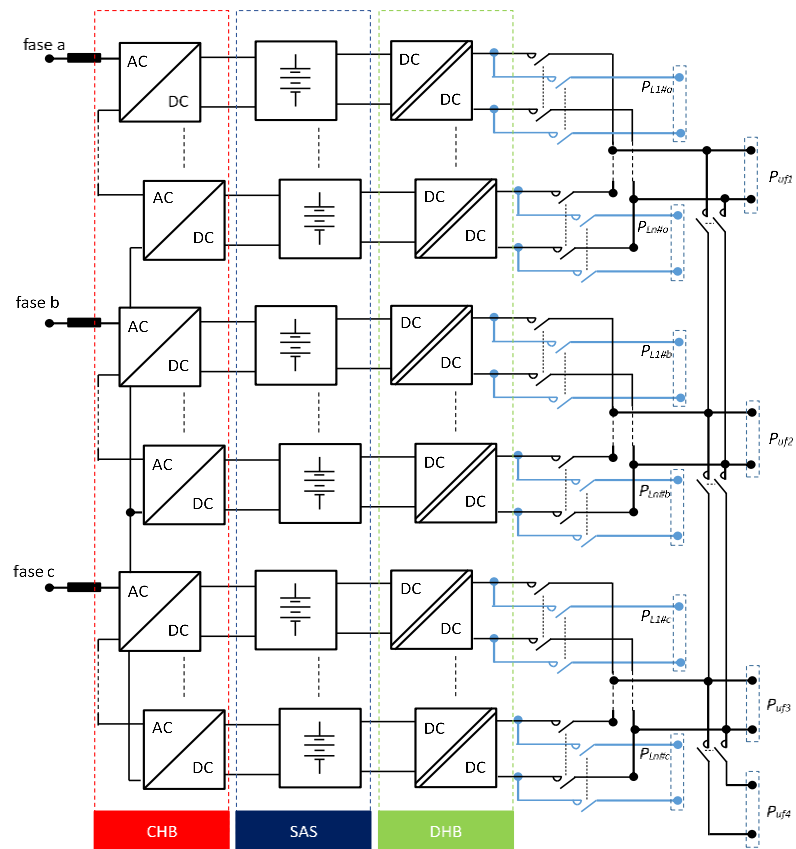

Ad esempio alimentare una serie di *plug di ricarica in modalità standard oppure una plug per la ricarica ultra-fast.*

Tale soluzione si presta molto bene anche all'uso multimodale delle infrastrutture di ricarica, sia per auto private che per autobus o furgoni elettrici.

Flessibilità della soluzione proposta consente una integrazione con un impianto di generazione da fonti rinnovabili.

Inoltre, la bidirezionalità degli stadi di conversione in uscita permette la facile implementazione della modalità inversa di ricarica "vehicle to grid".



Le funzioni di controllo alla base del funzionamento del sistema di conversione che sono state sviluppate sono:

- controllo della potenza attiva e reattiva lato rete;
- minimizzazione dell'impatto sulla rete in caso di carico squilibrato;
- minimizzazione dell'impatto delle ricariche sulla rete attraverso la gestione del sistema di accumulo stazionario;
- controllo dei processi di ricarica.

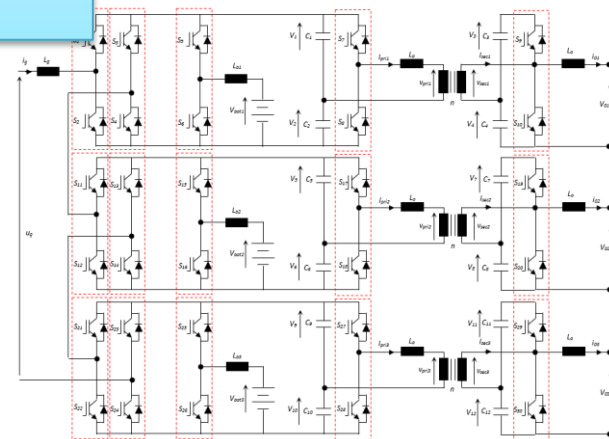

Antonino Genovese
ENEA DTE-PCU-STMA
C.R. Casaccia
Via Anguillarese 301
00123 Santa Maria di Galeria (Roma) - ITALY
tel. +39-06-30484186
antonino.genovese@enea.it

